



RADIO TEST REPORT

FCC ID : Z8H89FT0081
Equipment : 6084HH
Brand Name : Cambium Networks
Model Name : 6084HH
Applicant : Cambium Networks Inc.
3800 Golf Road, Suite 360 Rolling Meadows, IL
60008, USA
Manufacturer : Cambium Networks, Ltd.
Ashburton, TQ13 7UP, UK
Standard : 47 CFR FCC Part 15.407

The product was received on Sep. 05, 2023, and testing was started from Sep. 05, 2023 and completed on Nov. 13, 2023. We, Sporton International Inc. Hsinchu Laboratory, would like to declare that the tested sample has been evaluated in accordance with the procedures given in ANSI C63.10-2013 and shown compliance with the applicable technical standards.

The test results in this report apply exclusively to the tested model / sample. Without written approval of Sporton International Inc. Hsinchu Laboratory, the test report shall not be reproduced except in full.

Approved by: Sam Chen

Sporton International Inc. Hsinchu Laboratory

No. 8, Ln. 724, Bo'ai St., Zhubei City, Hsinchu County 302010, Taiwan (R.O.C.)



Table of Contents

History of this test report.....	3
Summary of Test Result.....	4
1 General Description	5
1.1 Information.....	5
1.2 Applicable Standards	9
1.3 Testing Location Information	9
1.4 Measurement Uncertainty	10
2 Test Configuration of EUT	11
2.1 Test Channel Mode	11
2.2 The Worst Case Measurement Configuration.....	13
2.3 EUT Operation during Test	13
2.4 Accessories	14
2.5 Support Equipment.....	14
2.6 Test Setup Diagram	15
3 Transmitter Test Result	18
3.1 AC Power-line Conducted Emissions	18
3.2 Emission Bandwidth.....	20
3.3 Maximum Output Power.....	21
3.4 Power Spectral Density	24
3.5 Unwanted Emissions.....	27
4 Test Equipment and Calibration Data	31
Appendix A. Test Results of AC Power-line Conducted Emissions	
Appendix B. Test Results of Emission Bandwidth	
Appendix C. Test Results of Maximum Output Power	
Appendix D. Test Results of Power Spectral Density	
Appendix E. Test Results of Unwanted Emissions	
Appendix F. Test Photos	
Photographs of EUT v01	



History of this test report

Report No.	Version	Description	Issued Date
FR380235	01	Initial issue of report	Nov. 06, 2023
FR380235	02	Revise Antennas' model name, add channels in UNII 3 for 20MHz/40MHz, and test the added channels	Nov. 17, 2023

Released under the Official Information Act 1982



Summary of Test Result

Report Clause	Ref Std. Clause	Test Items	Result (PASS/FAIL)	Remark
1.1.3	15.203	Antenna Requirement	PASS	-
3.1	15.207	AC Power-line Conducted Emissions	PASS	-
3.2	15.407(a)	Emission Bandwidth	PASS	-
3.3	15.407(a)	Maximum Output Power	PASS	-
3.4	15.407(a)	Power Spectral Density	PASS	-
3.5	15.407(b)	Unwanted Emissions	PASS	-

Conformity Assessment Condition:

1. The test results (PASS/FAIL) with all measurement uncertainty excluded are presented against the regulation limits or in accordance with the requirements stipulated by the applicant/manufacturer who shall bear all the risks of non-compliance that may potentially occur if measurement uncertainty is taken into account.
2. The measurement uncertainty please refer to each test result in the chapter "Measurement Uncertainty".

Disclaimer:

1. The product specifications of the EUT presented in the test report that may affect the test assessments are declared by the manufacturer who shall take full responsibility for the authenticity.
2. The test configuration, test mode and test software were written in this test report are declared by the manufacturer.

Reviewed by: Sam Chen
Report Producer: Sophia Shung



1 General Description

1.1 Information

1.1.1 RF General Information

Frequency Range (MHz)	Ch. Bandwidth (MHz)	Ch. Frequency (MHz)	Ch. Space (MHz)
5150-5250	5	5155-5244	1
5725-5850		5731-5844	1
5150-5250	10	5155-5245	1
5725-5850		5730-5845	1
5150-5250	15	5158-5242	1
5725-5850		5733-5842	1
5150-5250	20	5160-5240	1
5725-5850		5735-5840	1
5150-5250	30	5165-5235	1
5725-5850		5740-5835	1
5150-5250	40	5170-5230	1
5725-5850		5745-5830	1

Band	Mode	BWch (MHz)	Mod
5.15-5.25GHz	QPSK5	5	2TX
5.15-5.25GHz	QPSK10	10	2TX
5.15-5.25GHz	QPSK15	15	2TX
5.15-5.25GHz	QPSK20	20	2TX
5.15-5.25GHz	QPSK30	30	2TX
5.15-5.25GHz	QPSK40	40	2TX
5.725-5.85GHz	QPSK5	5	2TX
5.725-5.85GHz	QPSK10	10	2TX
5.725-5.85GHz	QPSK15	15	2TX
5.725-5.85GHz	QPSK20	20	2TX
5.725-5.85GHz	QPSK30	30	2TX
5.725-5.85GHz	QPSK40	40	2TX

Note:

- The 5GHz function uses QPSK modulation.
- BWch is the nominal channel bandwidth.



1.1.2 Table for Frequency Combination Mode

Type	Mode	Frequency (MHz)
1	UNII 1 (20+20 MHz) + UNII 3 (20+20 MHz)	UNII 1 (5180+5220) + UNII 3 (5755+5795)
2	UNII 1 (30+30 MHz) + UNII 3 (30+30 MHz)	UNII 1 (5180+5220) + UNII 3 (5755+5795)
3	UNII 1 (40+40 MHz) + UNII 3 (40+40 MHz)	UNII 1 (5175+5225) + UNII 3 (5750+5800)

Note: The above information was declared by manufacturer.

1.1.3 Antenna Information

Ant.	Port			Brand	Model Name	Antenna Type	Connector	Gain (dBi)
	R1	R2	R1+R2					
1	-	1	3	Cambium	Canopy V 4X4 Array Antenna	Array	RP-SMA	15.922
2	-	2	4	Cambium	Canopy V 4X4 Array Antenna	Array	RP-SMA	15.958
3	2	-	2	Cambium	Canopy V 4X4 Array Antenna	Array	RP-SMA	15.962
4	1	-	1	Cambium	Canopy V 4X4 Array Antenna	Array	RP-SMA	15.906

Note 1: The above information was declared by manufacturer

Note 2: Directional gain information

Type	Maximum Output Power	Power Spectral Density
Non-BF	Directional gain = Max gain + array gain For power measurements on IEEE 802.11 devices Array Gain = 0 dB (i.e., no array gain) for N ANT's	$\frac{P_{max}}{B_{ch}} = 10 \log \left(\frac{P_{max}}{B_{ch}} \right)$
BF	$\frac{P_{max}}{N_{ant}} = 10 \log \left(\frac{P_{max}}{N_{ant}} \right)$	$\frac{P_{max}}{B_{ch}} = 10 \log \left(\frac{P_{max}}{B_{ch}} \right)$

Ex.

Directional Gain (NSST) Formula

$$DG = 10 \log \left(\frac{P_{max}}{N_{ant}} \right) + 10 \log \left(\frac{P_{max}}{B_{ch}} \right)$$

$$NSST(g1,1) = 10 \log(P_{max}) ; NSST(g1,2) = 10 \log(P_{max}) ; NSST(g1,2) = 10 \log(P_{max}) ; NSST(g1,2) = 10 \log(P_{max})$$

$$DG = 10 \log \left(\frac{P_{max}}{N_{ant}} \right) + 10 \log \left(\frac{P_{max}}{B_{ch}} \right) + 10 \log \left(\frac{P_{max}}{B_{ch}} \right) + 10 \log \left(\frac{P_{max}}{B_{ch}} \right) + 10 \log \left(\frac{P_{max}}{B_{ch}} \right)$$

$$DG = 10 \log \left(\frac{P_{max}}{N_{ant}} \right) + 10 \log \left(\frac{P_{max}}{B_{ch}} \right) + 10 \log \left(\frac{P_{max}}{B_{ch}} \right) + 10 \log \left(\frac{P_{max}}{B_{ch}} \right) + 10 \log \left(\frac{P_{max}}{B_{ch}} \right) + 10 \log \left(\frac{P_{max}}{B_{ch}} \right)$$

$$10 \log \left(10 \log \left(\frac{P_{max}}{N_{ant}} \right) + 10 \log \left(\frac{P_{max}}{B_{ch}} \right) + 10 \log \left(\frac{P_{max}}{B_{ch}} \right) + 10 \log \left(\frac{P_{max}}{B_{ch}} \right) + 10 \log \left(\frac{P_{max}}{B_{ch}} \right) \right)$$

Where

Cross Polarized Antenna

$$5G \text{ UNII-1 G1} = 15.962 \text{ dBi}; \text{G2} = 15.906 \text{ dBi}$$

$$5G \text{ UNII-3 G1} = 15.922 \text{ dBi}; \text{G2} = 15.958 \text{ dBi}$$

$$5G \text{ UNII-1 DG} = 15.962 \text{ dBi}$$

$$5G \text{ UNII-3 DG} = 15.958 \text{ dBi}$$

**Note 3: For 5GHz function:****For Radio 1 (R1) (2TX/2RX):**

Port 1-2 can be used as transmitting/receiving antenna.

Port 1-2 could transmit/receive simultaneously.

For Radio 2 (R2) (2TX/2RX):

Port 1-2 can be used as transmitting/receiving antenna.

Port 1-2 could transmit/receive simultaneously.

For Radio 1 + Radio 2 (R1+R2) (2TX/2RX):

Port 1-4 can be used as transmitting/receiving antenna.

Port 1-4 could transmit/receive simultaneously.

1.1.4 Mode Test Duty Cycle**For other modes:**

Mode	DC	DCF(dB)	T ₁₀	VBW(Hz) ≥ 1/T
5.15-5.25GHz_QPSK5_5MHz_Nsst_2TX	0.075	0.31	2.437m	1k
5.15-5.25GHz_QPSK10_10MHz_Nsst_2TX	0.074	0.31	2.436m	1k
5.15-5.25GHz_QPSK15_15MHz_Nsst_2TX	0.074	0.31	2.436m	1k
5.15-5.25GHz_QPSK20_20MHz_Nsst_2TX	0.075	0.31	2.436m	1k
5.15-5.25GHz_QPSK30_30MHz_Nsst_2TX	0.074	0.31	2.435m	1k
5.15-5.25GHz_QPSK40_40MHz_Nsst_2TX	0.074	0.31	2.436m	1k
5.725-5.80GHz_QPSK5_5MHz_Nsst_2TX	0.075	0.31	2.437m	1k
5.725-5.80GHz_QPSK10_10MHz_Nsst_2TX	0.074	0.31	2.436m	1k
5.725-5.80GHz_QPSK15_15MHz_Nsst_2TX	0.074	0.31	2.436m	1k
5.725-5.80GHz_QPSK20_20MHz_Nsst_2TX	0.075	0.31	2.436m	1k
5.725-5.80GHz_QPSK30_30MHz_Nsst_2TX	0.074	0.31	2.435m	1k
5.725-5.80GHz_QPSK40_40MHz_Nsst_2TX	0.074	0.31	2.436m	1k

For frequency combination modes:

Mode	DC	DCF(dB)	T ₁₀	VBW(Hz) ≥ 1/T
QPSK20+20	0.076	0.03	2.005m	1k
QPSK30+30	0.076	0.08	2.043m	1k
QPSK40+40	0.077	0.01	2.072m	1k

Note:

- DC is Duty Cycle.
- DCF is Duty Cycle Factor.

**1.1.5 EUT Operational Condition**

EUT Power Type	From PoE			
Beamforming Function	<input type="checkbox"/>	With beamforming	<input checked="" type="checkbox"/>	Without beamforming
Function	<input checked="" type="checkbox"/>	Outdoor P2M	<input type="checkbox"/>	Indoor P2M
	<input type="checkbox"/>	Fixed P2P	<input type="checkbox"/>	Client
	<input checked="" type="checkbox"/>	Point-to-multipoint	<input type="checkbox"/>	Point-to-point
Test Software Version	DOS [ver 8.1.7601]			

Note: The above information was declared by manufacturer.

1.1.6 Table for Radio Function

Radio (R)	Function
R1	Support UNII 1 only
R2	Support UNII 3 only

Note: The above information was declared by manufacturer.



1.2 Applicable Standards

According to the specifications of the manufacturer, the EUT must comply with the requirements of the following standards:

- 47 CFR FCC Part 15
- ANSI C63.10-2013
- FCC KDB 76033 D02 v02r01

The following reference test guidance is not within the scope of accreditation of TAF:

- FCC KDB 662911 D01 v02r01
- FCC KDB 412172 D01 v01r01
- FCC KDB 414788 D01 v01r01

1.3 Testing Location Information

Testing Location Information

Test Lab. : Sporton International Inc. Hsinchu Laboratory	
Hsinchu (TAF: 3787)	ADD: No.8, Ln. 724, Bo'ai St., Zhubei City, Hsinchu County 302010, Taiwan (R.O.C.) TEL: 886-3-656-9065 FAX: 886-3-656-9065 Test site Designation No. TW3787 with FCC Conformity Assessment Body Identifier (CABID): TW3787 with ISED

Test Condition	Test Site No.	Test Engineer	Test Environment (°C / %)	Test Date
RF Conducted (For other frequencies)	1103-CB	Ken Yeh	23.4-24.5 / 52-81	Sep. 05, 2023- Oct. 04, 2023
RF Conducted (For 5735, 5880, 5245, 5820 MHz)	1103-CH	Ken Yeh	23.4-24.5 / 52-81	Nov. 13, 2023
Radiated < 102Hz	100303-CB	Ken Yeh	22-23 / 56-82	Oct. 17, 2023
Radiated < 102Hz (For other frequencies)	020303-CB	Frank Lu	21.7-22.9 / 56-82	Sep. 06, 2023- Sep. 27, 2023
	020303-CB		22.6-23.2 / 56-83	
Radiated > 102Hz (For 5735, 5880, 5245, 5820 MHz)	020305-CH	Frank Lu	22.9-23 / 56-81	Nov. 10, 2023
AC Conduction	C002-CH	Gray Lee	22-23 / 55-86	Oct. 18, 2023



1.4 Measurement Uncertainty

ISO/IEC 17025 requires that an estimate of the measurement uncertainties associated with the emissions test results be included in the report. The measurement uncertainties given below are based on a 95% confidence level (based on a coverage factor (k=2))

Parameter	Uncertainty	Remark
Conducted Emission (150kHz ~ 30MHz)	3.4 dB	Confidence levels of 95%
Radiated Emission (9kHz ~ 30MHz)	3.7 dB	Confidence levels of 95%
Radiated Emission (30MHz ~ 1,000MHz)	5.1 dB	Confidence levels of 95%
Radiated Emission (1GHz ~ 18GHz)	4.1 dB	Confidence levels of 95%
Radiated Emission (18GHz ~ 40GHz)	4.2 dB	Confidence levels of 95%
Conducted Emission	3.1 dB	Confidence levels of 95%
Output Power Measurement	0.8 dB	Confidence levels of 95%
Power Density Measurement	3.1 dB	Confidence levels of 95%
Bandwidth Measurement	2.2%	Confidence levels of 95%

Released under FR380235
Official Information



2 Test Configuration of EUT

2.1 Test Channel Mode

For other modes:

Mode	Power Setting
QPSK5_5MHz_Nw1_2TX	
515MHz	-19.5(121500)
5200MHz	-21.5(121500)
524MHz	-17.5(125500)
5211MHz	-18.5(185500)
5707MHz	-18(1840)
584MHz	-17(125500)
QPSK10_10MHz_Nw1_2TX	
515MHz	-33(1815000)
5200MHz	-18(126000)
5245MHz	-18(120000)
5700MHz	-18(1840)
5707MHz	-17.5(125500)
5845MHz	-18.5(124500)
QPSK15_15MHz_Nw1_2TX	
515MHz	-29(1217000)
5200MHz	-14.5(122000)
5242MHz	-11.5(82500)
5733MHz	-18(126000)
5787MHz	-15(120000)
5842MHz	-18(120000)
QPSK20_20MHz_Nw1_2TX	
5160MHz	-34.5(1818000)
5200MHz	-16.5(8210500)
5240MHz	-13(82000)
5735MHz	-18(121000)
5780MHz	-17.5(125500)
5840MHz	-18(124000)
QPSK30_30MHz_Nw1_2TX	
5160MHz	-14(120000)
5200MHz	-14(123000)
5250MHz	-18(84000)
5240MHz	-15.5(127000)
5707MHz	-18.5(125500)
5830MHz	-13.5(121500)



Mode	Power Setting
QPSK40_40MHz_Nvs1_2Tx	-
5170MHz	-31.5 (12/19000)
5200MHz	-35 (12/20000)
5230MHz	-34 (9/20000)
5740MHz	-38 (12/20000)
5770MHz	-38 (12/20000)
5830MHz	-35.5 (12/20000)

For frequency combination modes:

Mode	Power Setting
QPSK00+20_20MHz+20MHz_Nvs1_2Tx(Port1+Port2) F5150MHz, F5200MHz, 5750MHz, 5760MHz	-13 (12/1000)
QPSK00+20_20MHz+20MHz_Nvs1_2Tx(Port3+Port4) F5100MHz, 5200MHz, 5750MHz, 5760MHz	-13 (12/1000)
QPSK00+30_30MHz+30MHz_Nvs1_2Tx(Port1+Port2) F5150MHz, F5200MHz, 5750MHz, 5760MHz	-33.5 (6/4500)
QPSK00+30_30MHz+30MHz_Nvs1_2Tx(Port3+Port4) F5100MHz, 5200MHz, 5750MHz, 5760MHz	-33.5 (6/4500)
QPSK40+40_40MHz+40MHz_Nvs1_2Tx(Port1+Port2) F5170MHz, F5220MHz, 5770MHz, 5800MHz	-17 (9/6000)
QPSK40+40_40MHz+40MHz_Nvs1_2Tx(Port3+Port4) F5170MHz, 5200MHz, 5770MHz, 5800MHz	-17 (9/6000)

Released Under the Official Information Act 1982



2.2 The Worst Case Measurement Configuration

The Worst Case Mode for Following Conformance Tests	
Tests Item	AC power-line conducted emissions
Condition	AC power-line conducted measurement for line and neutral Test Voltage: 120Vac / 60Hz
Operating Mode	CTX
	After evaluating, EUT in Y axis was the worst case, so the measurement will follow this same test configuration.
↑	EUT in Y axis + PoE

The Worst Case Mode for Following Conformance Tests	
Tests Item	Emission Bandwidth Maximum Output Power Power Spectral Density
Test Condition	Conducted measurement at transmit chains

The Worst Case Mode for Following Conformance Tests	
Tests Item	Unwanted Emissions
Test Condition	Radiated measurement If EUT consist of multiple antenna assembly (multiple antenna are used in EUT regardless of spatial multiplexing MIMO configuration), the radiated test should be performed with highest antenna gain of each antenna type.
Operating Mode < 1GHz	CTX
	After evaluating, EUT in Y axis was the worst case, so the measurement will follow this same test configuration.
↑	EUT in Y axis + PoE
Operating Mode > 1GHz	CTX
	After evaluating, EUT in Y axis was the worst case, so the measurement will follow this same test configuration.
↑	EUT in Y axis

Note: The PoE was for measurement only and would not be marketed. Its information is shown as below:

Equipment	Brand Name	Model Name
PoE	Cambium	NET-P60-56IN

2.3 EUT Operation during Test

The EUT was programmed to be in continuously transmitting mode.



2.4 Accessories

Wall bracket*1

2.5 Support Equipment

For AC Conduction:

Support Equipment				
No.	Equipment	Brand Name	Model Name	FCC ID
A	PoE	Cambium	NET-P60-568N	N/A
B	LAN NB	DELL	E6430	N/A

For Radiated (below 1GHz):

Support Equipment				
No.	Equipment	Brand Name	Model Name	FCC ID
A	PoE	Cambium	NET-P60-568N	N/A
B	LAN NB	DELL	E6430	N/A

For Radiated (above 1GHz) and RF Conducted:

Support Equipment				
No.	Equipment	Brand Name	Model Name	FCC ID
A	Notebook	DELL	E4300	N/A
B	PoE	Cambium	NET-P60-568N	N/A



2.6 Test Setup Diagram

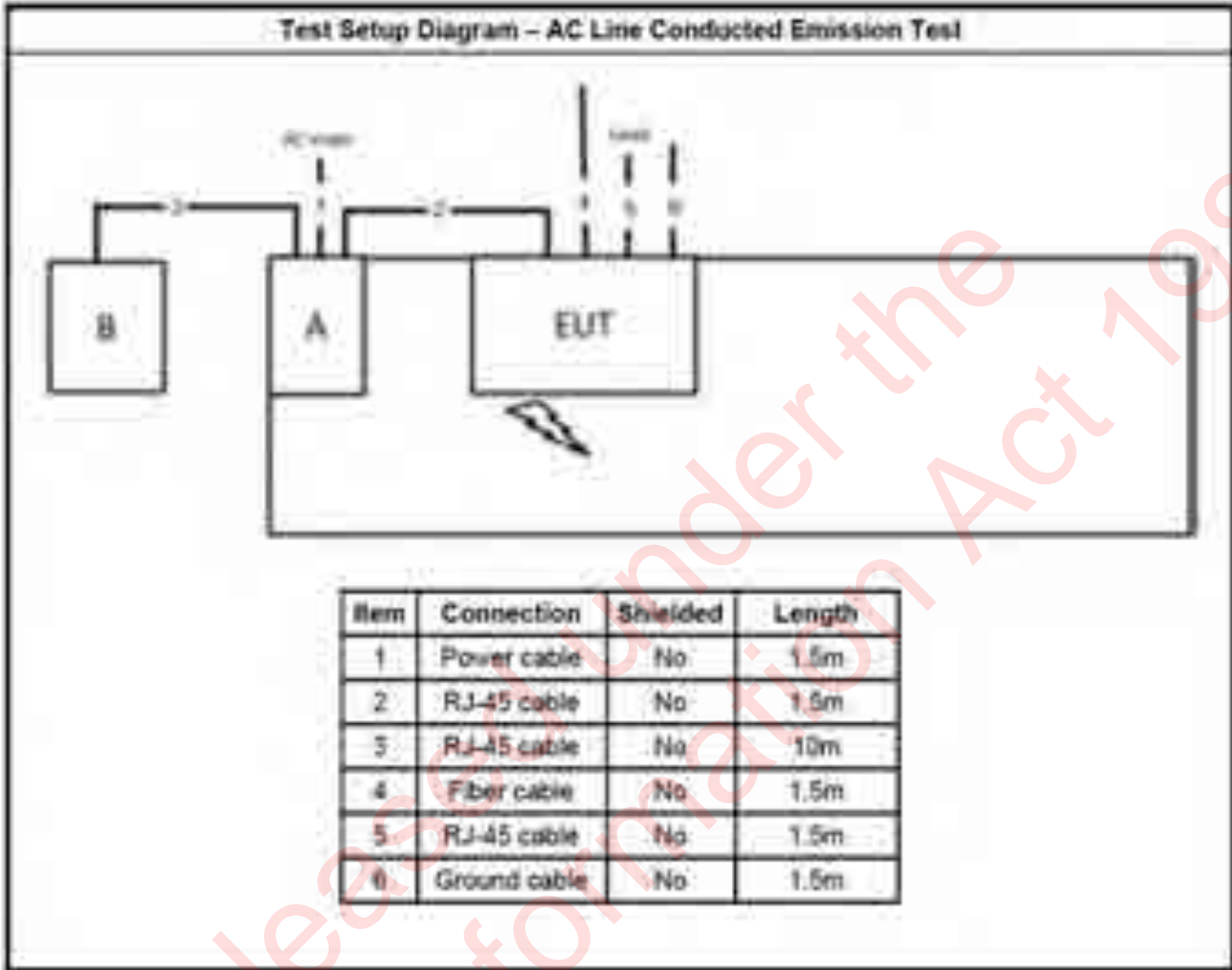



Test Setup Diagram - Radiated Test < 1GHz

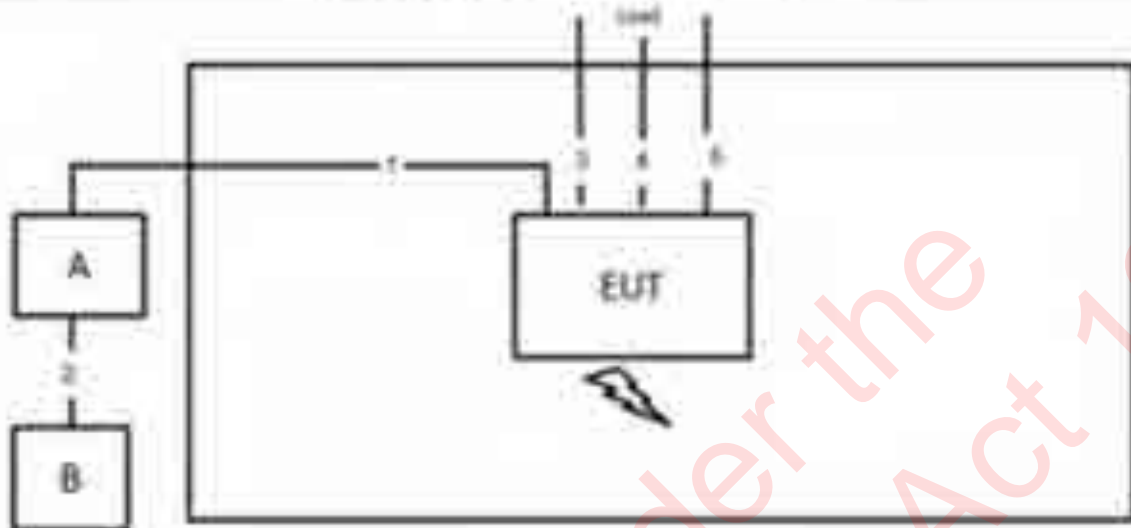

Item	Connection	Shielded	Length
1	RJ-45 cable	Yes	10m
2	RJ-45 cable	No	1.5m
3	Fiber cable	No	1m
4	RJ-45 cable	No	1.5m
5	GND cable	No	1.5m



Test Setup Diagram - Radiated Test > 1GHz

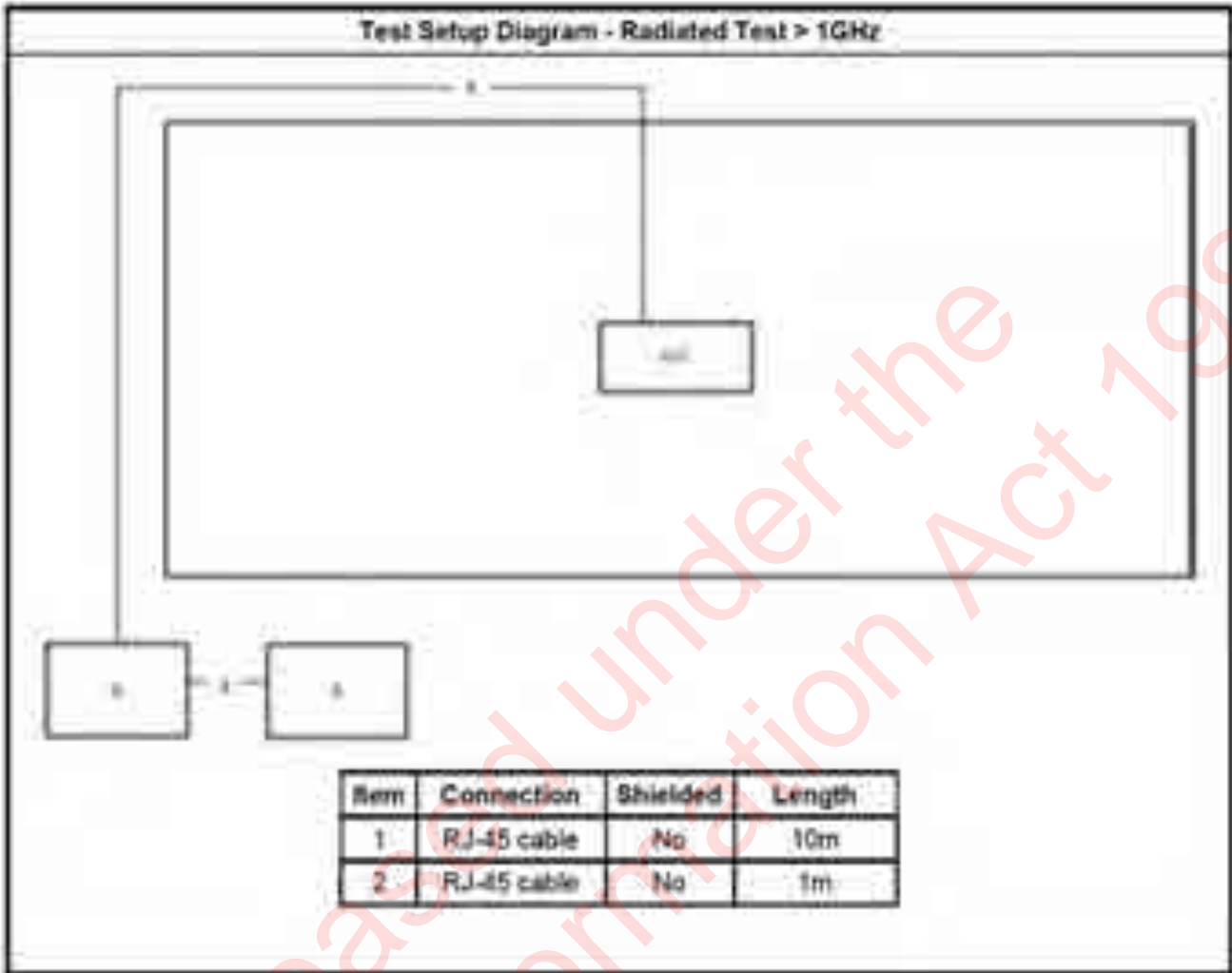

Released under the Official Information Act 1982



3 Transmitter Test Result

3.1 AC Power-line Conducted Emissions

3.1.1 AC Power-line Conducted Emissions Limit

AC Power-line Conducted Emissions Limit		
Frequency Emission (MHz)	Quasi-Peak	Average
0.15-0.5	66 - 50 *	56 - 40 *
0.5-5	56	46
5-30	60	50

Note 1: * Decreases with the logarithm of the frequency.

3.1.2 Measuring Instruments

Refer a test equipment and calibration data table in this test report.

3.1.3 Test Procedures

Test Method
<input checked="" type="checkbox"/> Refer as ANSI C63.10-2013, clause 6.2 for AC power-line conducted emissions.



3.1.4 Test Setup

AC Power-line Conducted Emissions

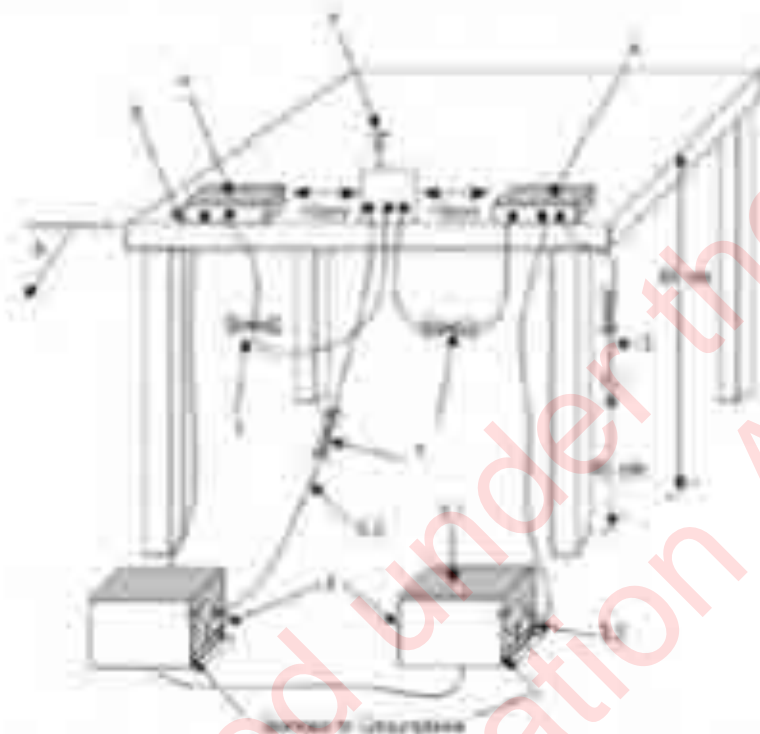

- 1—Interconnecting cables that hang closer than 40 cm to the ground plane shall be folded back and forth in the center forming a bundle 30 cm to 40 cm long.
- 2—The I/O cables that are not connected to an accessory shall be bundled in the center. The end of the cable may be terminated, if required, using the correct terminating impedance. The overall length shall not exceed 1 m.
- 3—EUT connected to one LISN. Unused LISN measuring port connectors shall be terminated in 50 Ω loads. LISN may be placed on top of, or immediately beneath, reference ground plane.
 - 3.1—All other equipment powered from additional LISN(s)
 - 3.2—A multiple-outlet strip may be used for multiple power cords of non-EUT equipment.
 - 3.3—LISN at least 80 cm from nearest part of EUT chassis.
- 4—Non-EUT components of EUT system being tested.
- 5—Rear of EUT, including peripherals, shall all be aligned and flush with edge of tabletop.
- 6—Edge of tabletop shall be 40 cm removed from a vertical conducting plane that is bonded to the ground plane.
- 7—Antenna can be integral or detachable. If detachable, then the antenna shall be attached for this test.

3.1.5 Measurement Results Calculation

The measured Level is calculated using

- a. Corrected Reading = LISN Factor (LISN) + Attenuator (AT/AUX) + Cable Loss (CL) + Read Level (RLW) + Level
- b. Margin = -Limit + Level

3.1.6 Test Result of AC Power-line Conducted Emissions:

Refer as Appendix A.



3.2 Emission Bandwidth

3.2.1 Emission Bandwidth Limit

Emission Bandwidth Limit	
UNII Devices	
<input checked="" type="checkbox"/>	For the 5.15-5.25 GHz band, N/A
<input type="checkbox"/>	For the 5.25-5.35 GHz band, the maximum conducted output power shall not exceed the lesser of 250 mW or $11 \text{ dBm} + 10 \log B$, where B is the 26 dB emission bandwidth in MHz.
<input type="checkbox"/>	For the 5.47-5.725 GHz band, the maximum conducted output power shall not exceed the lesser of 250 mW or $11 \text{ dBm} + 10 \log B$, where B is the 26 dB emission bandwidth in MHz.
<input checked="" type="checkbox"/>	For the 5.725-5.85 GHz band, 26 dB emission bandwidth N/A, 6 dB emission bandwidth $\geq 500\text{kHz}$.
LE-LAN Devices	
<input type="checkbox"/>	For the band 5.15-5.25 GHz, the maximum e.i.r.p. shall not exceed 200 mW or $10 + 10 \log B$, dBm, whichever power is less. B is the 99% emission bandwidth in MHz.
<input type="checkbox"/>	For the 5.25-5.35 GHz band, the maximum e.i.r.p. shall not exceed 1.0 W or $17 + 10 \log B$, dBm, whichever power is less. B is the 99% emission bandwidth in MHz.
<input type="checkbox"/>	For the 5.47-5.6 GHz band and 5.65-5.725 GHz band, the maximum e.i.r.p. shall not exceed 1.0 W or $17 + 10 \log B$, dBm, whichever power is less. B is the 99% emission bandwidth in MHz.
<input type="checkbox"/>	For the 5.725-5.85 GHz band, 6 dB emission bandwidth $\geq 500\text{kHz}$.

3.2.2 Measuring Instruments

Refer a test equipment and calibration data table in this test report.

3.2.3 Test Procedures

Test Method	
• For the emission bandwidth shall be measured using one of the options below:	
<input checked="" type="checkbox"/>	Refer as FCC KDB 78033 D02, clause C for EBW and clause D for OBW measurement.
<input type="checkbox"/>	Refer as ANSI C63.10, clause 6.9.1 for occupied bandwidth testing.
<input type="checkbox"/>	Refer as IC RSS-Gen, clause 4.6 for bandwidth testing.

3.2.4 Test Setup

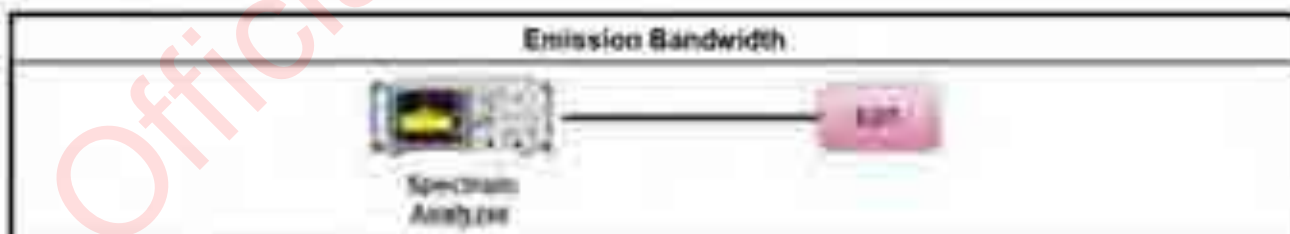

3.2.5 Test Result of Emission Bandwidth

Refer as Appendix B



3.3 Maximum Output Power

3.3.1 Limit

Maximum Output Power Limit	
UNII Devices	
<input checked="" type="checkbox"/>	For the 5.15-5.25 GHz band: <ul style="list-style-type: none"> Outdoor AP: the maximum conducted output power (P_{OAU}) shall not exceed the lesser of 1 W, if $G_{TX} > 6$ dBi, then $P_{OAU} = 30 - (G_{TX} - 6)$; e.i.r.p. at any elevation angle above 30 degrees ≤ 125mW (21dBm) Indoor AP: the maximum conducted output power (P_{OAU}) shall not exceed the lesser of 1 W, if $G_{TX} > 6$ dBi, then $P_{OAU} = 30 - (G_{TX} - 6)$ Point-to-point AP: the maximum conducted output power (P_{OAU}) shall not exceed the lesser of 1 W, if $G_{TX} > 23$ dBi, then $P_{OAU} = 30 - (G_{TX} - 23)$. Mobile or Portable Client: the maximum conducted output power (P_{OAU}) shall not exceed the lesser of 250 mW, if $G_{TX} > 6$ dBi, then $P_{OAU} = 24 - (G_{TX} - 6)$.
<input type="checkbox"/>	For the 5.25-5.35 GHz band, the maximum conducted output power (P_{OAU}) shall not exceed the lesser of 250 mW or $11 \text{ dBm} + 10 \log B$, where B is the 26 dB emission bandwidth in MHz. If $G_{TX} > 6$ dBi, then $P_{OAU} = 24 - (G_{TX} - 6)$.
<input type="checkbox"/>	For the 5.47-5.725 GHz band, the maximum conducted output power (P_{OAU}) shall not exceed the lesser of 250 mW or $11 \text{ dBm} + 10 \log B$, where B is the 26 dB emission bandwidth in MHz. If $G_{TX} > 6$ dBi, then $P_{OAU} = 24 - (G_{TX} - 6)$.
<input checked="" type="checkbox"/>	For the 5.725-5.85 GHz band: <ul style="list-style-type: none"> Point-to-multipoint systems (P2M): the maximum conducted output power (P_{OAU}) shall not exceed the lesser of 1 W, if $G_{TX} > 6$ dBi, then $P_{OAU} = 30 - (G_{TX} - 6)$. Point-to-point systems (P2P): the maximum conducted output power (P_{OAU}) shall not exceed the lesser of 1 W.
LE-LAN Devices	
<input type="checkbox"/>	For the 5.15-5.25 GHz band, the maximum e.i.r.p. shall not exceed 200 mW or $10 + 10 \log B$, dBm, whichever power is less. B is the 99% emission bandwidth in MHz.
<input type="checkbox"/>	For the 5.25-5.35 GHz band, the maximum e.i.r.p. shall not exceed 1.0 W or $17 + 10 \log B$, dBm, whichever power is less. B is the 99% emission bandwidth in MHz.
<input type="checkbox"/>	For the 5.47-5.6 GHz band and 5.65-5.725 GHz band, the maximum e.i.r.p. shall not exceed 1.0 W or $17 + 10 \log B$, dBm, whichever power is less. B is the 99% emission bandwidth in MHz.
<input type="checkbox"/>	For the 5.725-5.85 GHz band: <ul style="list-style-type: none"> Point-to-multipoint systems (P2M): the maximum conducted output power (P_{OAU}) shall not exceed the lesser of 1 W, if $G_{TX} > 6$ dBi, then $P_{OAU} = 30 - (G_{TX} - 6)$. Point-to-point systems (P2P): the maximum conducted output power (P_{OAU}) shall not exceed the lesser of 1 W.
P_{OAU} = maximum conducted output power in dBm. G_{TX} = the maximum transmitting antenna directional gain in dBi.	



3.3.2 Measuring Instruments

Refer a test equipment and calibration data table in this test report.

3.3.3 Test Procedures

Test Method	
	Average over on/off periods with duty factor
<input checked="" type="checkbox"/>	Refer as FCC KDB 789033 D02, clause E Method SA-2 (spectral trace averaging)
<input type="checkbox"/>	Refer as FCC KDB 789033 D02, clause E Method SA-2 Alt. (RMS detection with slow sweep speed)
	Wideband RF power meter and average over on/off periods with duty factor
<input checked="" type="checkbox"/>	Refer as FCC KDB 789033 D02, clause E Method PM-G (using an RF average power meter)
<input checked="" type="checkbox"/>	For conducted measurement:
	<ul style="list-style-type: none">If the EUT supports multiple transmit chains using options given below: Refer as FCC KDB 652911, In-band power measurements. Using the measure-and-sum approach, measured all transmit ports individually. Sum the power (in linear power units e.g., mW) of all ports for each individual sample and save them.If multiple transmit chains, EIRP calculation could be following as methods: $P_{\text{Total}} = P_1 + P_2 + \dots + P_n$ (calculated in linear unit [mW] and transfer to log unit [dBm]) $EIRP_{\text{Total}} = P_{\text{Total}} + DG$
<input type="checkbox"/>	For radiated measurement:
	<ul style="list-style-type: none">Refer as FCC KDB 789033 D02 clause B.A.1.F "Antenna-port Conducted versus Radiated Testing"Refer as ANSI C63.10, clause 6.6 for radiated emissions above 1GHz.Refer as FCC KDB 412172 D01 clause 2.2 for EIRP calculation.



3.3.4 Test Setup

For frequency combination modes:

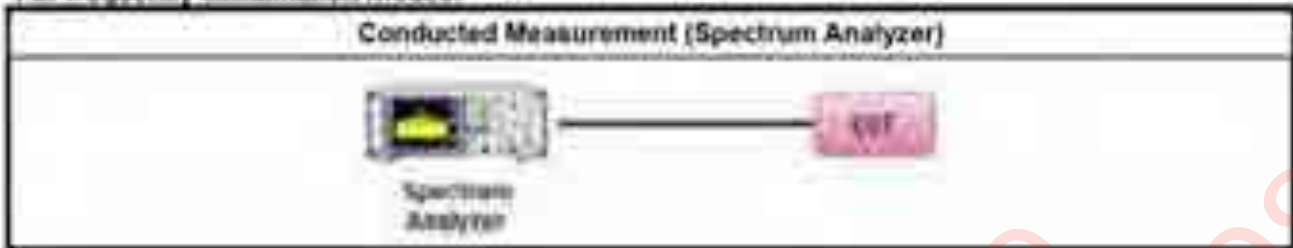

For other modes:

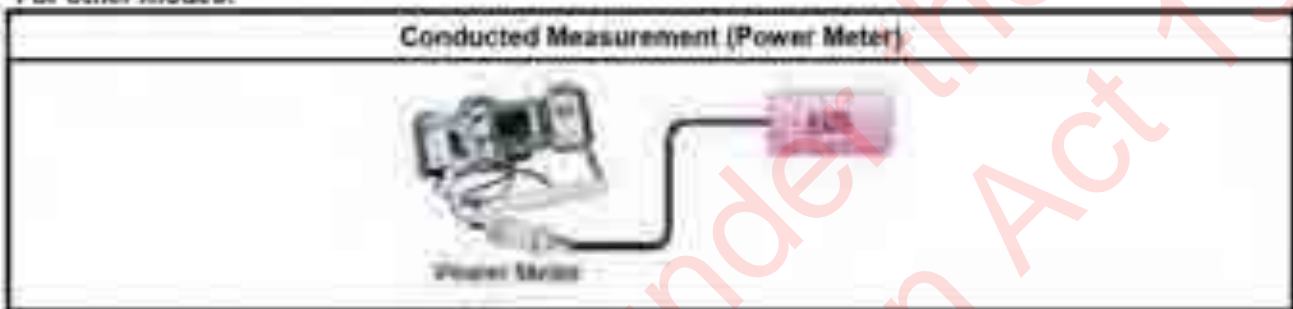

3.3.5 Test Result of Maximum Output Power

Refer as Appendix C

Released under the Official Information Act 1982



3.4 Power Spectral Density

3.4.1 Limit

Peak Power Spectral Density Limit	
UNII Devices	
<input checked="" type="checkbox"/>	For the 5.15-5.25 GHz band: <ul style="list-style-type: none"> Outdoor AP: the peak power spectral density (PPSD) shall not exceed the lesser of 17dBm/MHz. If $G_{rx} > 6$ dBi then $P_{Out} = 17 - (G_{rx} - 6)$. Indoor AP: the peak power spectral density (PPSD) shall not exceed the lesser of 17dBm/MHz. If $G_{rx} > 6$ dBi then $P_{Out} = 17 - (G_{rx} - 6)$. Point-to-point AP: the peak power spectral density (PPSD) shall not exceed the lesser of 17dBm/MHz. If $G_{rx} > 23$ dBi then $P_{Out} = 17 - (G_{rx} - 23)$. Mobile or Portable Client: the peak power spectral density (PPSD) ≤ 11 dBm/MHz. If $G_{rx} > 6$ dBi then $PPSD = 11 - (G_{rx} - 6)$.
<input type="checkbox"/>	For the 5.25-5.35 GHz band, the peak power spectral density (PPSD) ≤ 11 dBm/MHz. If $G_{rx} > 6$ dBi then $PPSD = 11 - (G_{rx} - 6)$.
<input type="checkbox"/>	For the 5.47-5.725 GHz band, the peak power spectral density (PPSD) ≤ 11 dBm/MHz. If $G_{rx} > 6$ dBi then $PPSD = 11 - (G_{rx} - 6)$.
<input checked="" type="checkbox"/>	For the 5.725-5.85 GHz band: <ul style="list-style-type: none"> Point-to-multipoint systems (P2M): the peak power spectral density (PPSD) ≤ 30 dBm/500kHz. If $G_{rx} > 6$ dBi, then $PPSD = 30 - (G_{rx} - 6)$. Point-to-point systems (P2P): the peak power spectral density (PPSD) ≤ 30 dBm/500kHz.
LE-LAN Devices	
<input type="checkbox"/>	For the 5.15-5.25 GHz band, the e.i.r.p. peak power spectral density (PPSD) ≤ 10 dBm/MHz.
<input type="checkbox"/>	For the 5.25-5.35 GHz band, the peak power spectral density (PPSD) ≤ 11 dBm/MHz. <ul style="list-style-type: none"> e.i.r.p. greater than 200 mW shall comply with the following e.i.r.p. at different elevations, where θ is the angle above the local horizontal plane (of the Earth) as shown below: <ul style="list-style-type: none"> -13 dBW/MHz for $0^\circ \leq \theta < 8^\circ$, -13 - 0,71$\theta$ (B-8) dBW/MHz for $8^\circ \leq \theta < 40^\circ$ -35,9 - 1,22 (B-40) dBW/MHz for $40^\circ \leq \theta \leq 45^\circ$, -42 dBW/MHz for $\theta > 45^\circ$
<input type="checkbox"/>	For the 5.47-5,6 GHz band and 5.85-5.725 GHz band, the peak power spectral density (PPSD) ≤ 11 dBm/MHz.
<input type="checkbox"/>	For the 5.725-5.85 GHz band: <ul style="list-style-type: none"> Point-to-multipoint systems (P2M): the peak power spectral density (PPSD) ≤ 30 dBm/500kHz. If $G_{rx} > 6$ dBi, then $PPSD = 30 - (G_{rx} - 6)$. Point-to-point systems (P2P): the peak power spectral density (PPSD) ≤ 30 dBm/500kHz.
PPSD = peak power spectral density that the same method as used to determine the conducted output power shall be used to determine the power spectral density. And power spectral density in dBm/MHz G_{rx} = the maximum transmitting antenna directional gain in dBi.	

3.4.2 Measuring Instruments

Refer a test equipment and calibration data table in this test report.



3.4.3 Test Procedures

Test Method	
<ul style="list-style-type: none"> Peak power spectral density procedures that the same method as used to determine the conducted output power shall be used to determine the peak power spectral density and use the peak search function on the spectrum analyzer to find the peak of the spectrum. For the peak power spectral density shall be measured using below options: 	
<input type="checkbox"/>	Refer as FCC KDB 789033 D02, F(5) power spectral density can be measured using resolution bandwidths < 1 MHz provided that the results are integrated over 1 MHz bandwidth [duty cycle ≥ 98% or external video / power trigger]
<input checked="" type="checkbox"/>	Refer as FCC KDB 789033 D02, clause E Method SA-1 (spectral trace averaging)
<input type="checkbox"/>	Refer as FCC KDB 789033 D02, clause E Method SA-1 Alt. (RMS detection with slow sweep speed) duty cycle < 98% and average over on/off periods with duty factor.
<input checked="" type="checkbox"/>	Refer as FCC KDB 789033 D02, clause E Method SA-2 (spectral trace averaging)
<input type="checkbox"/>	Refer as FCC KDB 789033 D02, clause E Method SA-2 Alt. (RMS detection with slow sweep speed)
<input checked="" type="checkbox"/> For conducted measurement.	
<ul style="list-style-type: none"> If the EUT supports multiple transmit chains using options given below: 	
<input checked="" type="checkbox"/>	Option 1: Measure and sum the spectra across the outputs. Refer as FCC KDB 662911, In-band power spectral density (PSD). Sample all transmit ports simultaneously using a spectrum analyzer for each transmit port. Where the trace bin-by-bin of each transmit port summing can be performed, (i.e., is the first spectral bin of output 1 is summed with that in the first spectral bin of output 2 and that from the first spectral bin of output 3, and so on up to the Nth output to obtain the value for the first frequency bin of the summed spectrum.) Add up the amplitude (power) values for the different transmit chains and use this as the new data trace
<input type="checkbox"/>	Option 2: Measure and sum spectral maxima across the outputs. With this technique, spectra are measured at each output of the device at the required resolution bandwidth. The maximum value (peak) of each spectrum is determined. These maximum values are then summed mathematically in linear power units across the outputs. These operations shall be performed separately over frequency spans that have different out-of-band or spurious emission limits
<input type="checkbox"/>	Option 3: Measure and add 10 log(N) dB, where N is the number of transmit chains. Refer as FCC KDB 662911, In-band power spectral density (PSD). Performed at each transmit chains and each transmit chains shall be compared with the limit have been reduced with 10 log(N). Or each transmit chains shall be add 10 log(N) to compared with the limit
<ul style="list-style-type: none"> If multiple transmit chains, EIRP PPSD calculation could be following as methods: $PPSD_{total} = PPSD_1 + PPSD_2 + \dots + PPSD_n$ (calculated in linear unit [mW] and transfer to log unit [dBm]) $EIRP_{total} = PPSD_{total} + DG$ 	
<input type="checkbox"/> For radiated measurement.	
<ul style="list-style-type: none"> Refer as FCC KDB 789033 D02 clause II A, 1.F "Antenna-port Conducted versus Radiated Testing" Refer as ANSI C63.10, clause 6.6 for radiated emissions above 1GHz. Refer as FCC KDB 412172 D01 clause 2.2 for EIRP calculation. 	



3.4.4 Test Setup

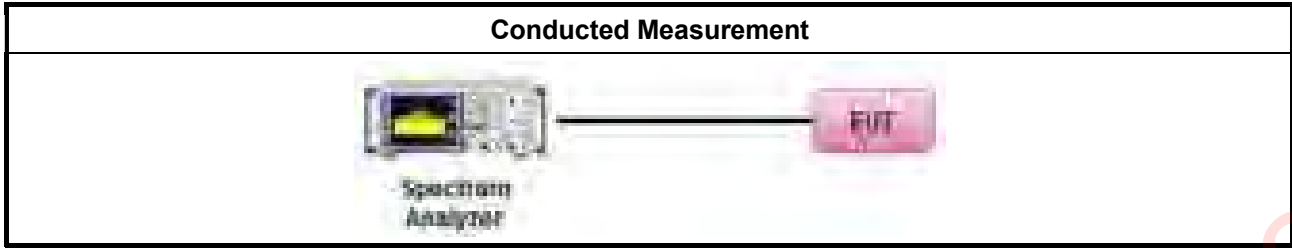

3.4.5 Test Result of Power Spectral Density

Refer as Appendix D

Released under the Official Information Act 1982



3.5 Unwanted Emissions

3.5.1 Transmitter Unwanted Emissions Limit

Unwanted emissions below 1 GHz and restricted band emissions above 1GHz limit

Frequency Range (MHz)	Field Strength ($\mu\text{V/m}$)	Field Strength ($\text{dB}\mu\text{V/m}$)	Measure Distance (m)
0.008-0.490	2400/F(kHz)	48.5 - 13.8	300
0.490-1.705	24000/F(kHz)	33.8 - 23	30
1.705-30.0	30	29	30
30-88	100	40	3
88-216	150	43.5	3
216-960	200	46	3
Above 960	500	54	3

Note 1: Test distance for frequencies at or above 30 MHz, measurements may be performed at a distance other than the limit distance provided they are not performed in the near field and the emissions to be measured can be detected by the measurement equipment. When performing measurements at a distance other than that specified, the results shall be extrapolated to the specified distance using an extrapolation factor of 20 dB/decade (inverse of linear distance for field-strength measurements, inverse of linear distance-squared for power-density measurements).

Note 2: Test distance for frequencies at below 30 MHz, measurements may be performed at a distance closer than the EUT limit distance, however, an attempt should be made to avoid making measurements in the near field. When performing measurements below 30 MHz at a closer distance than the limit distance, the results shall be extrapolated to the specified distance by either making measurements at a minimum of two or more distances on at least one radial to determine the proper extrapolation factor or by using the square of an inverse linear distance extrapolation factor (40 dB/decade). The test report shall specify the extrapolation method used to determine compliance of the EUT.

Note 3: Using the distance of 1m during the test for above 18 GHz, and the test value to correct for the distance factor at 3m.



Un-restricted band emissions above 1GHz Limit	
Operating Band	Limit
<input checked="" type="checkbox"/> 5.15 - 5.25 GHz	e.i.r.p. -27 dBm [88.2 dBuV/m@3m]
<input type="checkbox"/> 5.25 - 5.35 GHz	e.i.r.p. -27 dBm [88.2 dBuV/m@3m]
<input type="checkbox"/> 5.47 - 5.725 GHz	e.i.r.p. -27 dBm [88.2 dBuV/m@3m]
<input checked="" type="checkbox"/> 5.725 - 5.85 GHz	all emissions shall be limited to a level of -27 dBm/MHz at 75 MHz or more above or below the band edge increasing linearly to 10 dBm/MHz at 25 MHz above or below the band edge, and from 25 MHz above or below the band edge increasing linearly to a level of 15.6 dBm/MHz at 5 MHz above or below the band edge, and from 5 MHz above or below the band edge increasing linearly to a level of 27 dBm/MHz at the band edge

Note 1: Measurements may be performed at a distance other than the limit distance provided they are not performed in the near field and the emissions to be measured can be detected by the measurement equipment. When performing measurements at a distance other than that specified, the results shall be extrapolated to the specified distance using an extrapolation factor of 20 dB/decade (inverse of linear distance for field-strength measurements, inverse of linear distance-squared for power-density measurements).

3.5.2 Measuring Instruments

Refer a test equipment and calibration data table in this test report.

3.5.3 Test Procedures

Test Method
<ul style="list-style-type: none"> Measurements may be performed at a distance other than the limit distance provided they are not performed in the near field and the emissions to be measured can be detected by the measurement equipment. Measurements shall not be performed at a distance greater than 30 m for frequencies above 30 MHz, unless it can be further demonstrated that measurements at a distance of 30 m or less are impractical. When performing measurements at a distance other than that specified, the results shall be extrapolated to the specified distance using an extrapolation factor of 20 dB/decade (inverse of linear distance for field-strength measurements, inverse of linear distance-squared for power-density measurements).
<ul style="list-style-type: none"> The average emission levels shall be measured in [duty cycle \geq 98 or duty factor].
<ul style="list-style-type: none"> For the transmitter unwanted emissions shall be measured using following options below: <ul style="list-style-type: none"> Refer as FCC KDB 789033 D02, clause G)2) for unwanted emissions into non-restricted bands. Refer as FCC KDB 789033 D02, clause G)1) for unwanted emissions into restricted bands. <ul style="list-style-type: none"> <input type="checkbox"/> Refer as FCC KDB 789033 D02, G)6) Method AD (Trace Averaging). <input checked="" type="checkbox"/> Refer as FCC KDB 789033 D02, G)8) Method VB (Reduced VBW). <input type="checkbox"/> Refer as ANSI C63.10, clause 11.12.2.5.3 (Reduced VBW), VBW \geq 1/T, where T is pulse time. <input checked="" type="checkbox"/> Refer as ANSI C63.10, clause 7.5 average value of pulsed emissions <input checked="" type="checkbox"/> Refer as FCC KDB 789033 D02, clause G)5) measurement procedure peak limit. <input type="checkbox"/> Refer as ANSI C63.10, clause 4.1.4.2.2 measurement procedure peak limit.



Test Method	
• For radiated measurement,	
• Refer as ANSI C63.10, clause 6.4 for radiated emissions below 30 MHz and test distance is 3m.	
• Refer as ANSI C63.10, clause 6.5 for radiated emissions 30 MHz to 1 GHz and test distance is 3m.	
• Refer as ANSI C63.10, clause 6.6 for radiated emissions above 1GHz.	
• The any unwanted emissions level shall not exceed the fundamental emission level.	
• All amplitude of spurious emissions that are attenuated by more than 20 dB below the permissible value has no need to be reported.	

3.5.4 Test Setup

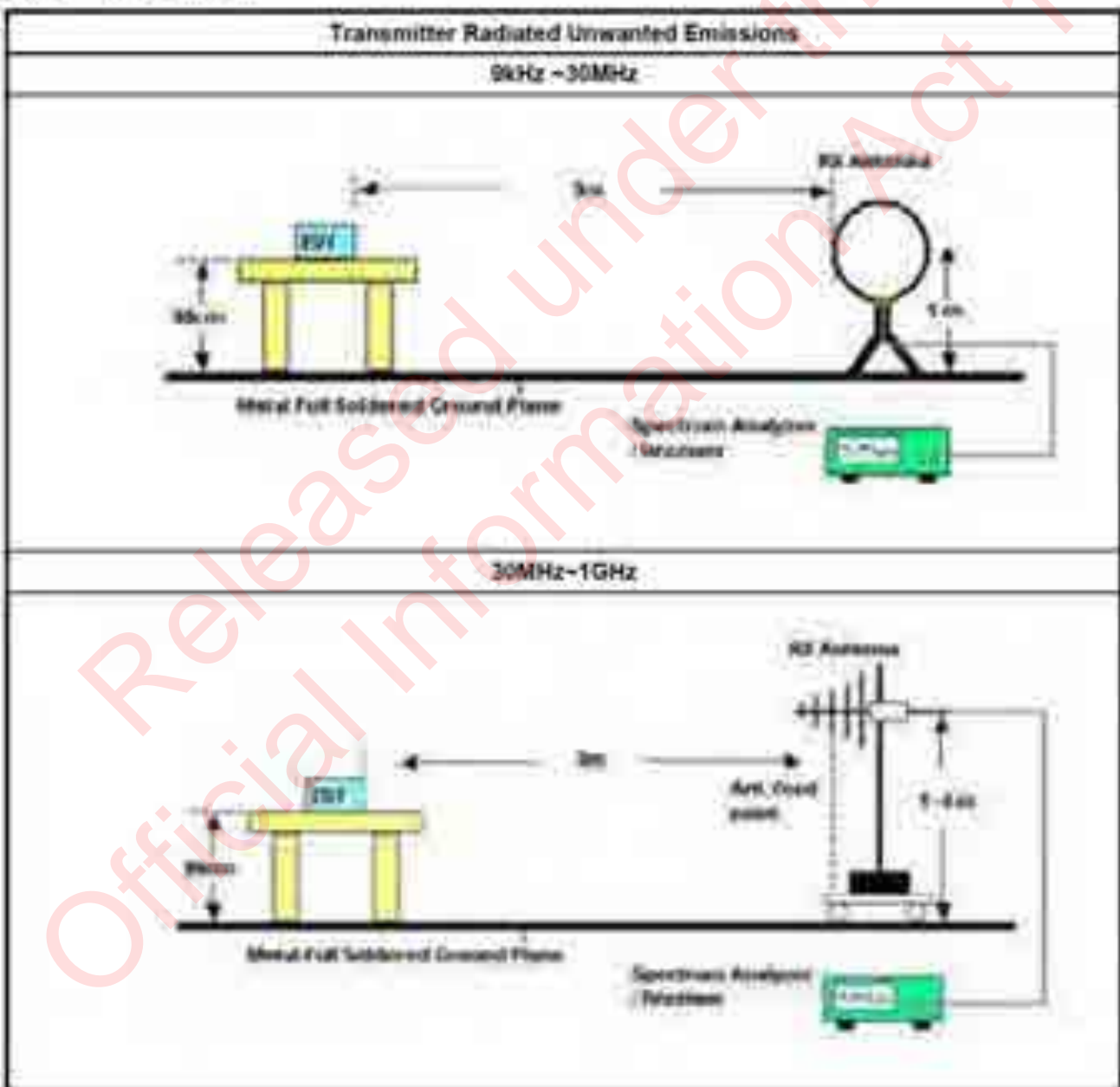

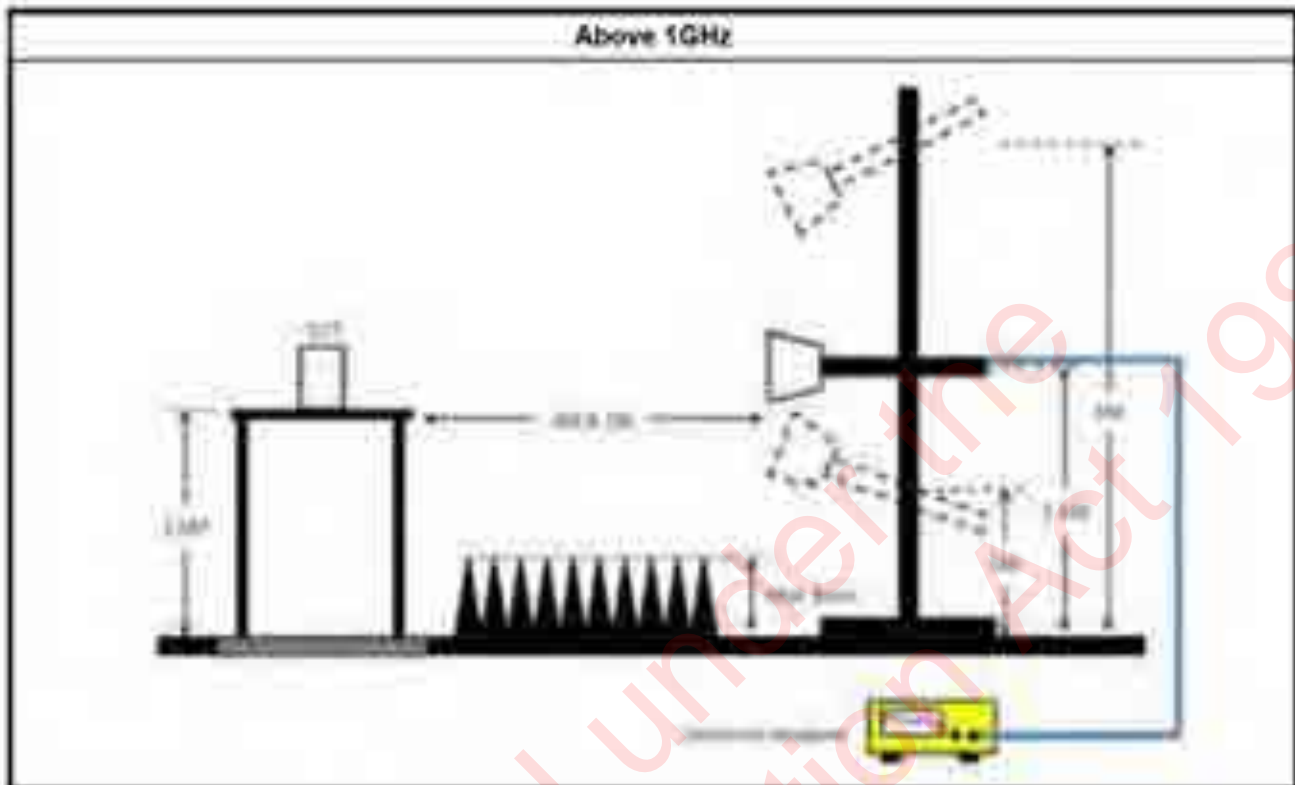

3.5.5 Measurement Results Calculation

The measured Level is calculated using:

Corrected Reading: Antenna factor (AF) + Cable loss (CL) + Read level (Raw) - Preamp factor (PA)(if applicable) = Level.

3.5.6 Transmitter Unwanted Emissions (Below 30MHz)

There is a comparison data of both open-field test site and alternative test site - semi-Anechoic chamber according to KDB414788 Radiated Test Site, and the result came out very similar.

All amplitude of spurious emissions that are attenuated by more than 20 dB below the permissible value has no need to be reported.

The radiated emissions were investigated from 9 kHz or the lowest frequency generated within the device, up to the 10th harmonic or 40 GHz, whichever is appropriate.

3.5.7 Test Result of Transmitter Unwanted Emissions

Refer as Appendix E

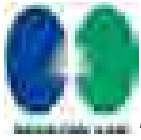

4 Test Equipment and Calibration Data

Instrument	Brand	Model No.	Serial No.	Characteristics	Calibration Date	Calibration Due Date	Remark
LISN	Schwarzbeck	NSLK 8127	8127650	9kHz ~ 30MHz	Apr. 06, 2023	Apr. 05, 2024	Conduction (CO02-CB)
LISN	Schwarzbeck	NSLK 8127	8127478	9kHz ~ 30MHz	Dec. 20, 2022	Dec. 19, 2023	Conduction (CO02-CB)
EMI Receiver	Agilent	N9038A	MY52260140	9kHz ~ 8.4GHz	May 18, 2023	May 17, 2024	Conduction (CO02-CB)
COND Cable	Woken	Cable	2	0.15MHz ~ 30MHz	Oct. 17, 2023	Oct. 16, 2024	Conduction (CO02-CB)
Pulse Limiter	Schwarzbeck	VTSD 9561F-N	00378	9kHz ~ 30MHz	Oct. 17, 2023	Oct. 16, 2024	Conduction (CO02-CB)
Software	SPORTON	SENSE	V5.10	-	N.C.R.	N.C.R.	Conduction (CO02-CB)
10m Semi Anechoic Chamber NSA	TDK	SAC-10M	10CH01-CB	30MHz~1GHz 10m,3m	Jan. 18, 2023	Jan. 17, 2024	Radiation (10CH01-CB)
Amplifier	Agilent	8447D	2944A10783	9kHz ~ 1.3GHz	Mar. 10, 2023	Mar. 09, 2024	Radiation (10CH01-CB)
Amplifier	Agilent	8447D	2944A10784	9kHz ~ 1.3GHz	Mar. 10, 2023	Mar. 09, 2024	Radiation (10CH01-CB)
Low Cable	Woken	SUCOFLEX 104	low cable-01	25MHz ~ 1GHz	Oct. 18, 2022	Oct. 17, 2023	Radiation (10CH01-CB)
Low Cable	Woken	SUCOFLEX 104	low cable-02	25MHz ~ 1GHz	Oct. 18, 2022	Oct. 17, 2023	Radiation (10CH01-CB)
EMI Test Receiver	Rohde&Schwarz	ESCI	100186	9kHz ~ 3GHz	Jul. 11, 2023	Jul. 10, 2024	Radiation (10CH01-CB)
Spectrum Analyzer	Rohde&Schwarz	FSV30	101026	9kHz ~ 30GHz	Apr. 19, 2023	Apr. 18, 2024	Radiation (10CH01-CB)
Bilog Antenna with 6dB Attenuator	Chase & EMCi	CBL6111A &N-6-06	1543 &AT-N0609	30MHz ~ 1GHz	Jun. 24, 2023	Jun. 23, 2024	Radiation (10CH01-CB)
Amplifier	EM	EM101	060703	10MHz ~ 1GHz	Oct. 19, 2022	Oct. 18, 2023	Radiation (10CH01-CB)
Low Cable	TITAN	T318E	low cable-03	30MHz ~ 1GHz	Oct. 18, 2022	Oct. 17, 2023	Radiation (10CH01-CB)
Loop Antenna	Teseq	HLA 6120	31244	9kHz - 30 MHz	Mar. 23, 2023	Mar. 22, 2024	Radiation (10CH01-CB)
Software	SPORTON	SENSE	V5.10	-	N.C.R.	N.C.R.	Radiation (10CH01-CB)
3m Semi Anechoic Chamber VSWR	RIKEN	SAC-3M	03CH02-CB	1GHz ~18GHz	Mar. 25, 2023	Mar. 24, 2024	Radiation (03CH02-CB)
Horn Antenna	EMCO	3115	9610-4976	1GHz ~ 18GHz	Apr. 18, 2023	Apr. 17, 2024	Radiation (03CH02-CB)



Instrument	Brand	Model No.	Serial No.	Characteristics	Calibration Date	Calibration Due Date	Remark
Horn Antenna	SCHWARZBECK	BBHA 9170	BBHA9170507	15GHz ~ 40GHz	Jun. 28, 2023	Jun. 27, 2024	Radiation (03CH02-CB)
Pre-Amplifier	Agilent	83017A	MY39501305	1GHz ~ 26.5GHz	Jun. 30, 2023	Jun. 29, 2024	Radiation (03CH02-CB)
Pre-Amplifier	SGH	SGH184	20221107-3	18GHz ~ 40GHz	Nov. 16, 2022	Nov. 15, 2023	Radiation (03CH02-CB)
Spectrum analyzer	R&S	FSU	100015	9kHz~26GHz	Dec. 05, 2022	Dec. 04, 2023	Radiation (03CH02-CB)
RF Cable-high	Woken	RG402	High Cable-18	1GHz ~ 18GHz	Oct. 03, 2022	Oct. 02, 2023	Radiation (03CH02-CB)
RF Cable-high	Woken	RG402	High Cable-18+19	1GHz ~ 18GHz	Oct. 03, 2022	Oct. 02, 2023	Radiation (03CH02-CB)
High Cable	Woken	WCA0929M	40G#5+6	1GHz ~ 40 GHz	Dec. 07, 2022	Dec. 06, 2023	Radiation (03CH02-CB)
High Cable	Woken	WCA0929M	40G#5	1GHz ~ 40 GHz	Dec. 07, 2022	Dec. 06, 2023	Radiation (03CH02-CB)
High Cable	Woken	WCA0929M	40G#6	1GHz ~ 40 GHz	Dec. 07, 2022	Dec. 06, 2023	Radiation (03CH02-CB)
Test Software	SPORTON	SENSE	V5.10	-	N.C.R.	N.C.R.	Radiation (03CH02-CB)
3m Semi Anechoic Chamber VSWR	TDK	SAC-3M	03CH03-CB	1GHz ~18GHz 3m	May 04, 2023	May 03, 2024	Radiation (03CH03-CB)
Horn Antenna	ETS · Lindgren	3115	6821	750MHz~18GHz	Feb. 03, 2023	Feb. 02, 2024	Radiation (03CH03-CB)
Horn Antenna	SCHWARZBECK	BBHA 9170	BBHA9170507	15GHz ~ 40GHz	Jun. 28, 2023	Jun. 27, 2024	Radiation (03CH03-CB)
Pre-Amplifier	Agilent	8449B	3008A02097	1GHz ~ 26.5GHz	Jun. 30, 2023	Jun. 29, 2024	Radiation (03CH03-CB)
Pre-Amplifier	SGH	SGH184	20221107-3	18GHz ~ 40GHz	Nov. 16, 2022	Nov. 15, 2023	Radiation (03CH03-CB)
Spectrum Analyzer	R&S	FSP40	100019	9kHz ~ 40GHz	Jun. 12, 2023	Jun. 11, 2024	Radiation (03CH03-CB)
RF Cable-high	Woken	RG402	High Cable-20+29	1GHz ~ 18GHz	Oct. 03, 2022	Oct. 02, 2023	Radiation (03CH03-CB)
RF Cable-high	Woken	RG402	High Cable-29	1GHz ~ 18GHz	Oct. 03, 2022	Oct. 02, 2023	Radiation (03CH03-CB)
High Cable	Woken	WCA0929M	40G#5+6	1GHz ~ 40 GHz	Dec. 07, 2022	Dec. 06, 2023	Radiation (03CH03-CB)
High Cable	Woken	WCA0929M	40G#5	1GHz ~ 40 GHz	Dec. 07, 2022	Dec. 06, 2023	Radiation (03CH03-CB)
High Cable	Woken	WCA0929M	40G#6	1GHz ~ 40 GHz	Dec. 07, 2022	Dec. 06, 2023	Radiation (03CH03-CB)
Test Software	SPORTON	SENSE	V5.10	-	N.C.R.	N.C.R.	Radiation (03CH03-CB)

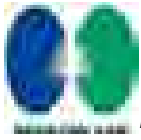

Instrument	Brand	Model No.	Serial No.	Characteristics	Calibration Date	Calibration Due Date	Remark
3m Semi Anechoic Chamber VSWR	TDK	SAC-3M	03CH05-CB	1GHz ~18GHz 3m	Sep. 29, 2023	Sep. 28, 2024	Radiation (03CH05-CB)
Horn Antenna	SCHWARZBECK	BBHA9120D	BBHA 9120 D-1291	1GHz~18GHz	Jun. 08, 2023	Jun. 07, 2024	Radiation (03CH05-CB)
Horn Antenna	SCHWARZBECK	BBHA 9170	BBHA9170507	15GHz ~ 40GHz	Jun. 28, 2023	Jun. 27, 2024	Radiation (03CH05-CB)
Pre-Amplifier	EMCI	EMC12630SE	980287	1GHz – 26.5GHz	Jun. 30, 2023	Jun. 29, 2024	Radiation (03CH05-CB)
Pre-Amplifier	SGH	SGH184	20221107-3	18GHz ~ 40GHz	Nov. 16, 2022	Nov. 15, 2023	Radiation (03CH05-CB)
Spectrum Analyzer	R&S	FSP40	100304	9kHz ~ 40GHz	Apr. 18, 2023	Apr. 17, 2024	Radiation (03CH05-CB)
RF Cable-high	Woken	RG402	High Cable-28	1GHz~18GHz	Oct. 02, 2023	Oct. 01, 2024	Radiation (03CH05-CB)
RF Cable-high	Woken	RG402	High Cable-04+28	1GHz~18GHz	Oct. 02, 2023	Oct. 01, 2024	Radiation (03CH05-CB)
High Cable	Woken	WCA0929M	40G#5+6	1GHz ~ 40 GHz	Dec. 07, 2022	Dec. 06, 2023	Radiation (03CH05-CB)
High Cable	Woken	WCA0929M	40G#5	1GHz ~ 40 GHz	Dec. 07, 2022	Dec. 06, 2023	Radiation (03CH05-CB)
High Cable	Woken	WCA0929M	40G#6	1GHz ~ 40 GHz	Dec. 07, 2022	Dec. 06, 2023	Radiation (03CH05-CB)
Test Software	SPORTON	SENSE	V5.10	-	N.C.R.	N.C.R.	Radiation (03CH05-CB)
Spectrum analyzer	R&S	FSV40	101028	9kHz~40GHz	Dec. 30, 2022	Dec. 29, 2023	Conducted (TH03-CB)
Power Sensor	Anritsu	MA2411B	1531344	300MHz~ 40GHz	Aug. 01, 2023	Jul. 31, 2024	Conducted (TH03-CB)
Power Meter	Anritsu	ML2495A	1728002	300MHz~ 40GHz	Aug. 01, 2023	Jul. 31, 2024	Conducted (TH03-CB)
RF Cable	Woken	RG402	High Cable-11	30MHz –18 GHz	Feb. 14, 2023	Feb. 13, 2024	Conducted (TH03-CB)
RF Cable	Woken	RG402	High Cable-12	30MHz –18 GHz	Feb. 14, 2023	Feb. 13, 2024	Conducted (TH03-CB)
RF Cable	Woken	RG402	High Cable-13	30MHz –18 GHz	Feb. 14, 2023	Feb. 13, 2024	Conducted (TH03-CB)
RF Cable-high	Woken	RG402	High Cable-14	1 GHz –18 GHz	Oct. 03, 2022	Oct. 02, 2023	Conducted (TH03-CB)
RF Cable-high	Woken	RG402	High Cable-14	1 GHz –18 GHz	Oct. 02, 2023	Oct. 01, 2024	Conducted (TH03-CB)
RF Cable-high	Woken	RG402	High Cable-15	1 GHz –18 GHz	Oct. 03, 2022	Oct. 02, 2023	Conducted (TH03-CB)
RF Cable-high	Woken	RG402	High Cable-15	1 GHz –18 GHz	Oct. 02, 2023	Oct. 01, 2024	Conducted (TH03-CB)



RADIO TEST REPORT

Report No. : FR380235

Instrument	Brand	Model No.	Serial No.	Characteristics	Calibration Date	Calibration Due Date	Remark
Switch	SPTCB	SP-SWI	SWI-03	1 GHz – 26.5 GHz	Oct. 04, 2022	Oct. 03, 2023	Conducted (TH03-CB)
Switch	SPTCB	SP-SWI	SWI-03	1 GHz – 26.5 GHz	Oct. 03, 2023	Oct. 02, 2024	Conducted (TH03-CB)
Test Software	SPORTON	SENSE	V5.10	-	N.C.R.	N.C.R.	Conducted (TH03-CB)

Note: Calibration Interval of instruments listed above is one year.

NCR means Non-Calibration required.

Released under the Official Information Act 1982



Summary

Mode	Result	Type	Freq (Hz)	Level (dBuV)	Limit (dBuV)	Margin (dB)	Condition
Mode 1	Pass	AV	16.467M	42.24	50.00	-7.76	Line

Released under the Official Information Act 1982



Released under the Official Information Act 1982





Summary

Unit	Meas ID P#	Meas-009 P#	ITP-Code	Meas ID P#	Meas-009 P#
LTS-2000	---	---	---	---	---
QPSA1 3000 Meas_278	3.000	4.000	980000	4.000	4.000
QPSA2 3000 Meas_278	10.000	9.000	980000	9.000	9.000
QPSB1 3000 Meas_278	14.000	11.000	180000	11.000	11.000
QPSB2 3000 Meas_278	10.000	10.000	180000	10.000	10.000
QPSA3 3000 Meas_278	17.000	14.000	180000	14.000	14.000
QPSA4 3000 Meas_278	18.000	16.000	980000	16.000	16.000
LTS-4000	---	---	---	---	---
QPSA1 3000 Meas_278	4.000	4.000	980000	4.000	4.000
QPSA2 3000 Meas_278	9.000	8.000	980000	8.000	8.000
QPSB1 3000 Meas_278	10.000	10.000	180000	10.000	10.000
QPSB2 3000 Meas_278	10.000	10.000	180000	10.000	10.000
QPSA3 3000 Meas_278	11.000	11.000	180000	11.000	11.000
QPSA4 3000 Meas_278	16.000	16.000	180000	16.000	16.000

Meas ID - Measure ID for comparison to ICA Measurement Method. All measurements starting
 Meas-009 - Measure ID for comparison
 ITP-Code - ITP Code for comparison to ICA Measurement Method. ITP Code for comparison to ICA
 Meas ID - Measure ID for comparison to ICA Measurement Method. All measurements starting

Released under the
 Official Information Act 1982



Result:

Mode	Result	Class 99%	Part 1-99 dB 99%	Part 1-00W 99%	Part 1-99 dB 99%	Part 1-00W 99%
OP150 150Hz, NoL JTE	--	--	--	--	--	--
17000Hz	Fail	99	4.700M	4.500M	4.600M	4.600M
17000Hz	Pass	99	4.800M	4.600M	4.700M	4.700M
17000Hz	Fail	99	4.900M	4.700M	4.800M	4.800M
17000Hz	Fail	99%	4.999M	4.799M	4.899M	4.899M
17000Hz	Fail	99%	4.9M	4.7M	4.8M	4.8M
17000Hz	Fail	99%	4.999M	4.799M	4.899M	4.8M
OP150 150Hz, NoL JTE	--	--	--	--	--	--
17000Hz	Fail	99	4.999M	4.799M	4.799M	4.799M
17000Hz	Fail	99	4.999M	4.799M	4.799M	4.799M
17000Hz	Fail	99	4.999M	4.799M	4.799M	4.799M
17000Hz	Fail	99%	4.999M	4.799M	4.799M	4.799M
17000Hz	Fail	99%	4.999M	4.799M	4.799M	4.799M
17000Hz	Fail	99%	4.999M	4.799M	4.799M	4.799M
OP150 150Hz, NoL JTE	--	--	--	--	--	--
17000Hz	Fail	99	11.000M	11.000M	11.000M	11.000M
17000Hz	Fail	99	11.000M	11.000M	11.000M	11.000M
17000Hz	Fail	99	11.000M	11.000M	11.000M	11.000M
17000Hz	Fail	99%	11.000M	11.000M	11.000M	11.000M
17000Hz	Fail	99%	11.000M	11.000M	11.000M	11.000M
17000Hz	Fail	99%	11.000M	11.000M	11.000M	11.000M
OP150 150Hz, NoL JTE	--	--	--	--	--	--
17000Hz	Fail	99	19.999M	19.999M	19.999M	19.999M
17000Hz	Fail	99	19.999M	19.999M	19.999M	19.999M
17000Hz	Fail	99	19.999M	19.999M	19.999M	19.999M
17000Hz	Fail	99%	19.999M	19.999M	19.999M	19.999M
17000Hz	Fail	99%	19.999M	19.999M	19.999M	19.999M
17000Hz	Fail	99%	19.999M	19.999M	19.999M	19.999M
OP150 150Hz, NoL JTE	--	--	--	--	--	--
17000Hz	Fail	99	24.000M	24.000M	24.000M	24.000M
17000Hz	Fail	99	24.000M	24.000M	24.000M	24.000M
17000Hz	Fail	99	24.000M	24.000M	24.000M	24.000M
17000Hz	Fail	99%	24.000M	24.000M	24.000M	24.000M
17000Hz	Fail	99%	24.000M	24.000M	24.000M	24.000M
17000Hz	Fail	99%	24.000M	24.000M	24.000M	24.000M
OP150 150Hz, NoL JTE	--	--	--	--	--	--
17000Hz	Fail	99	31.000M	31.000M	31.000M	31.000M
17000Hz	Fail	99	31.000M	31.000M	31.000M	31.000M
17000Hz	Fail	99	31.000M	31.000M	31.000M	31.000M
17000Hz	Fail	99%	31.000M	31.000M	31.000M	31.000M
17000Hz	Fail	99%	31.000M	31.000M	31.000M	31.000M
17000Hz	Fail	99%	31.000M	31.000M	31.000M	31.000M

Test 8.5.20 - Part 1-99 dB (Class 99) and Part 1-00W (Class 99) - 150 Hz (NoL) - JTE
 Test 8.5.20 - Part 1-99 dB (Class 99) and Part 1-00W (Class 99) - 150 Hz (NoL) - JTE

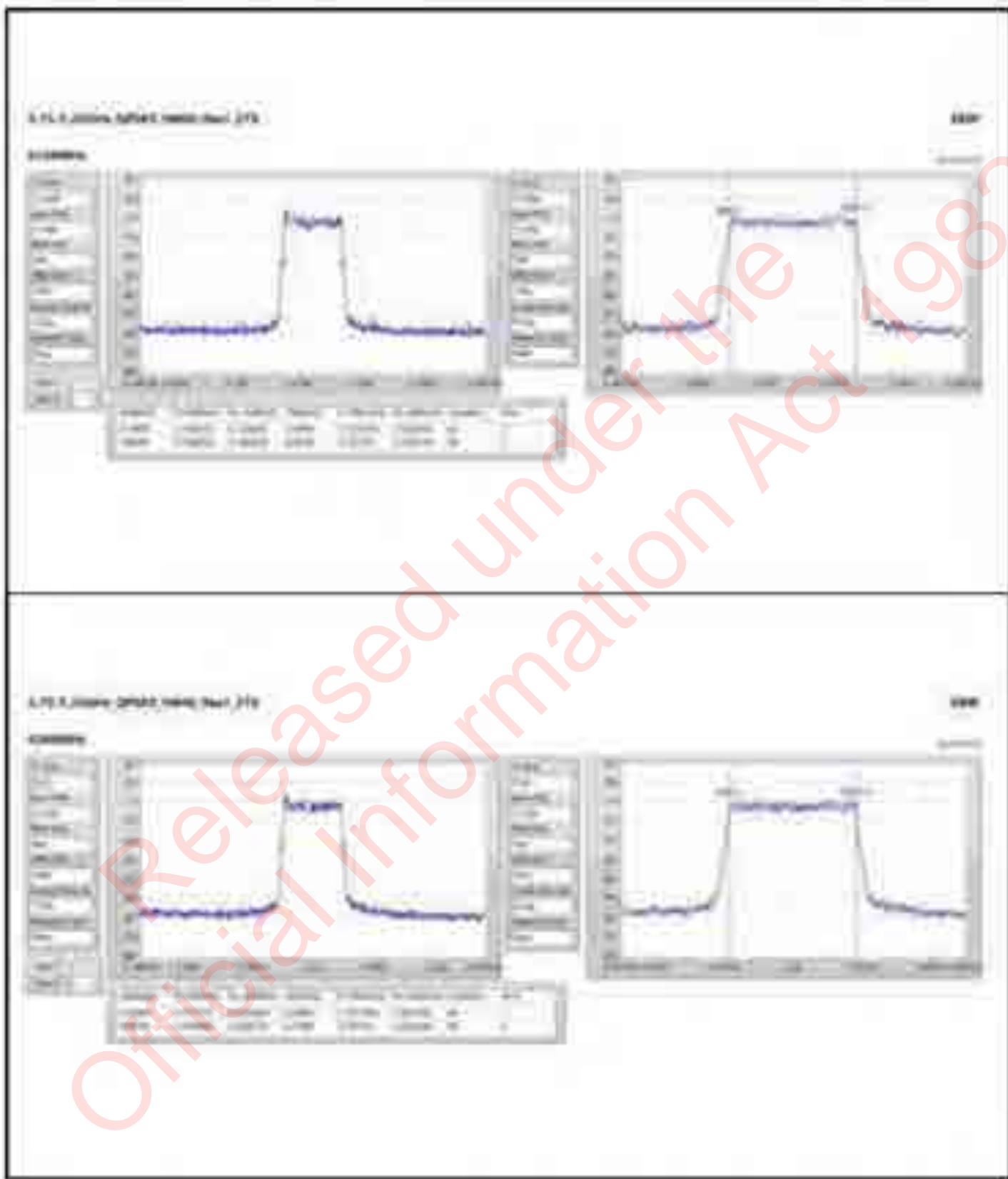

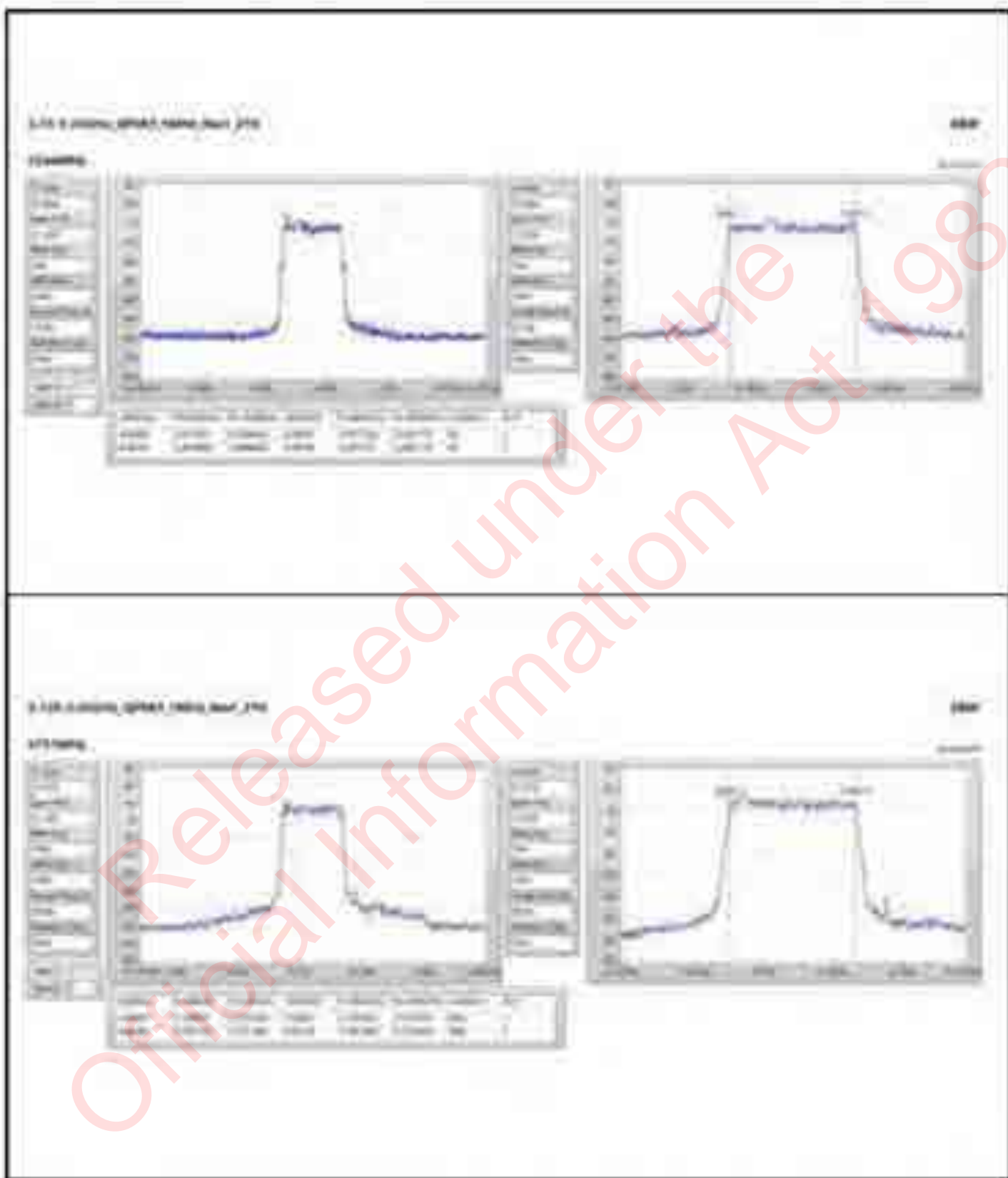

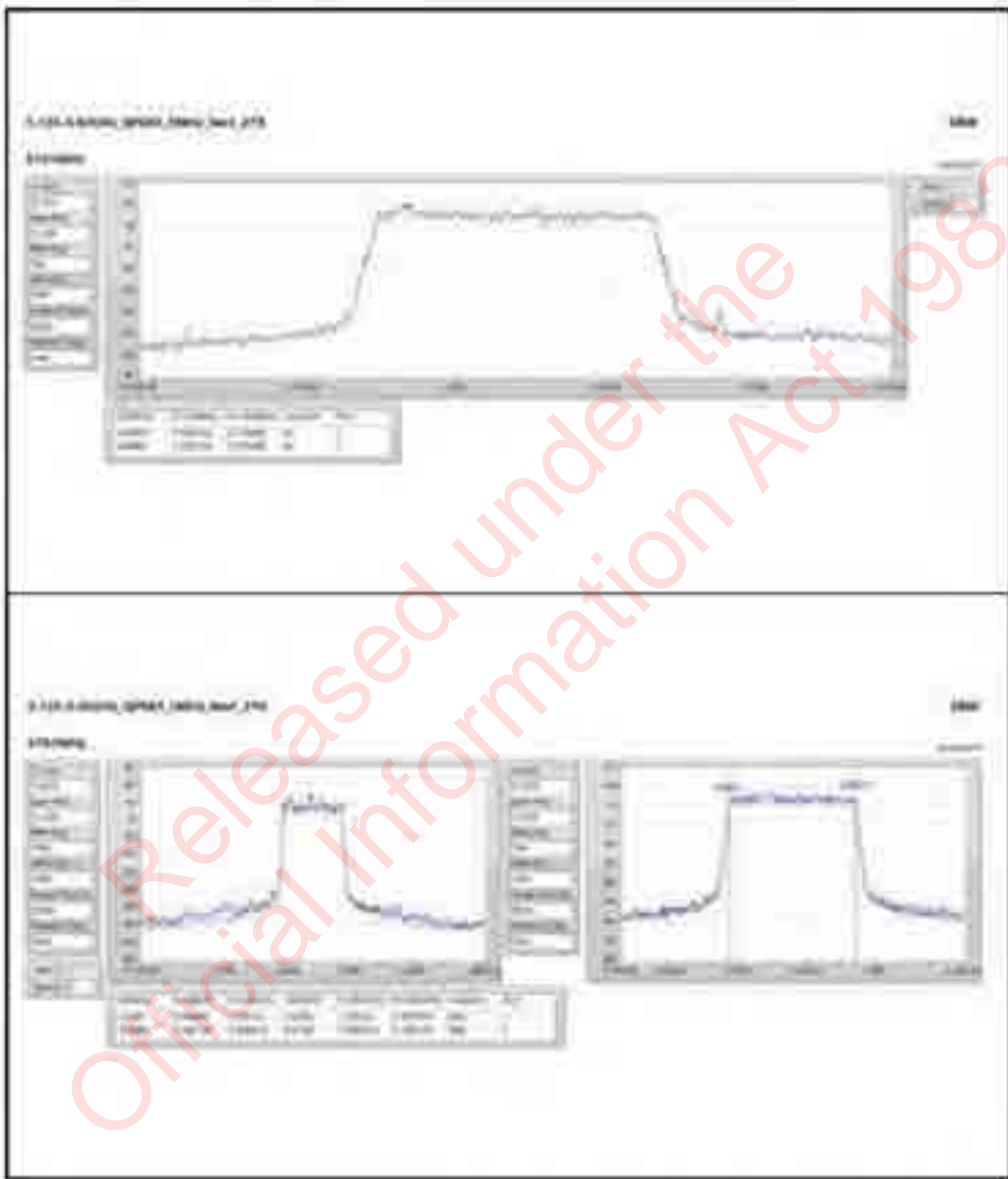

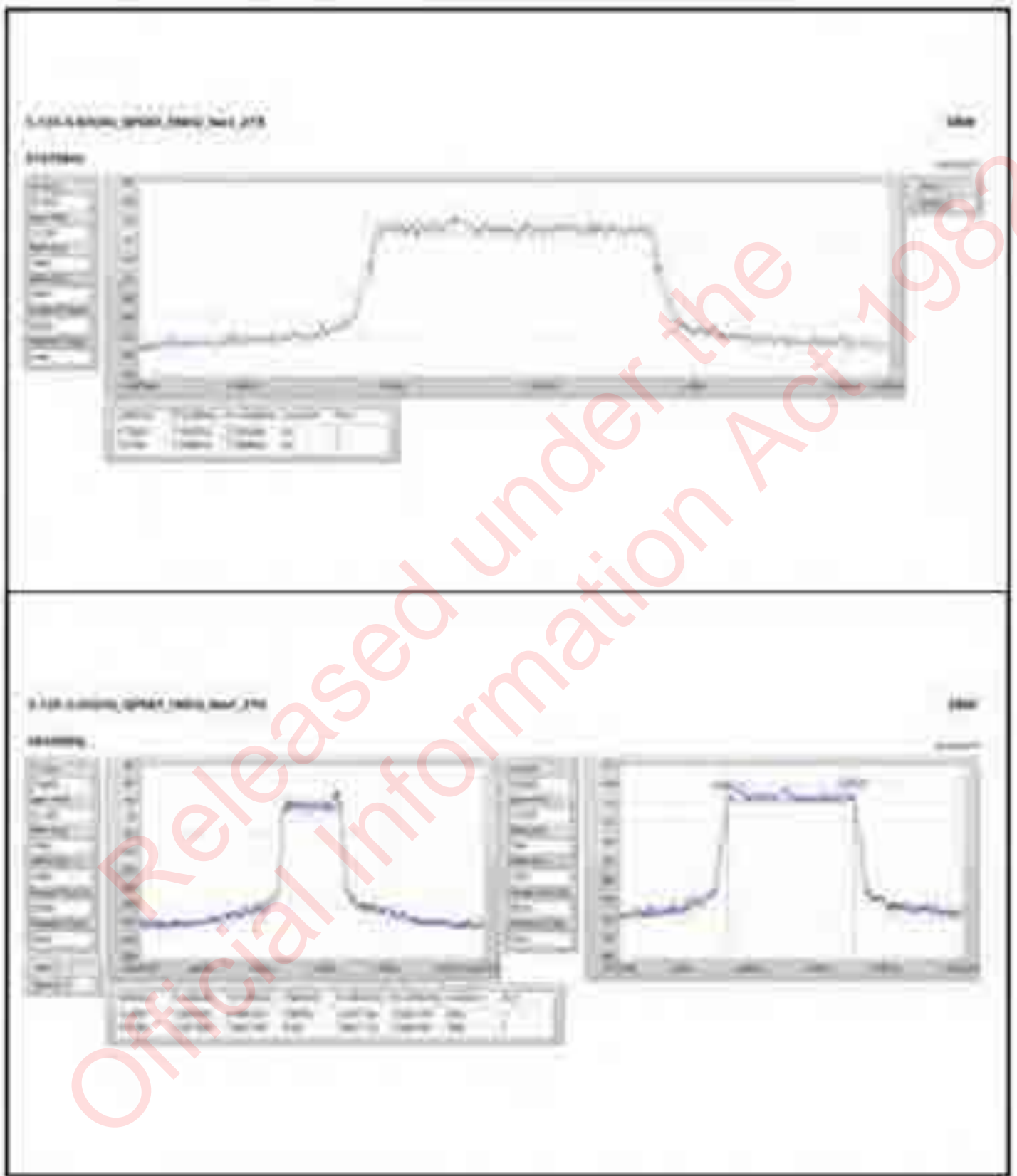



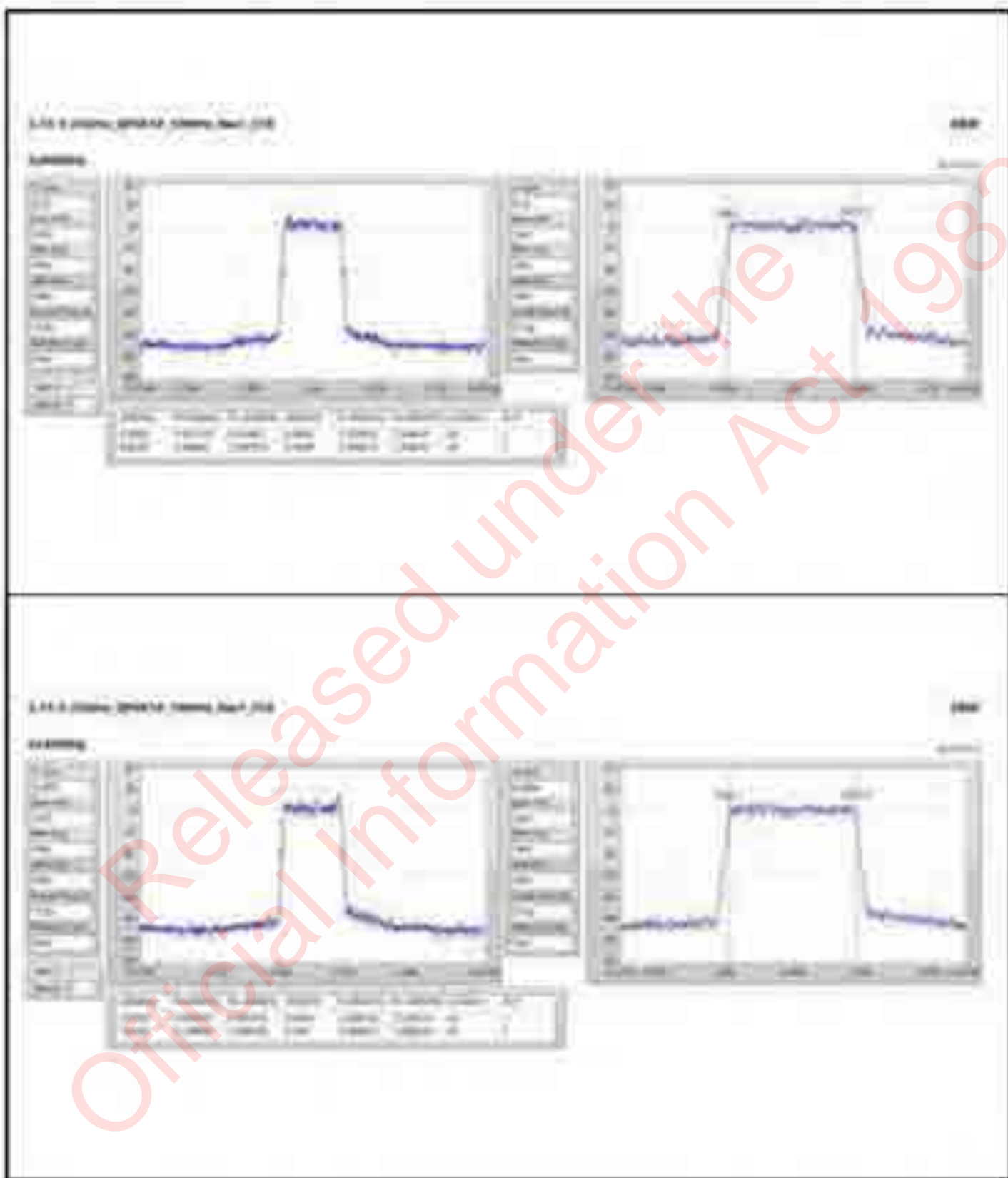

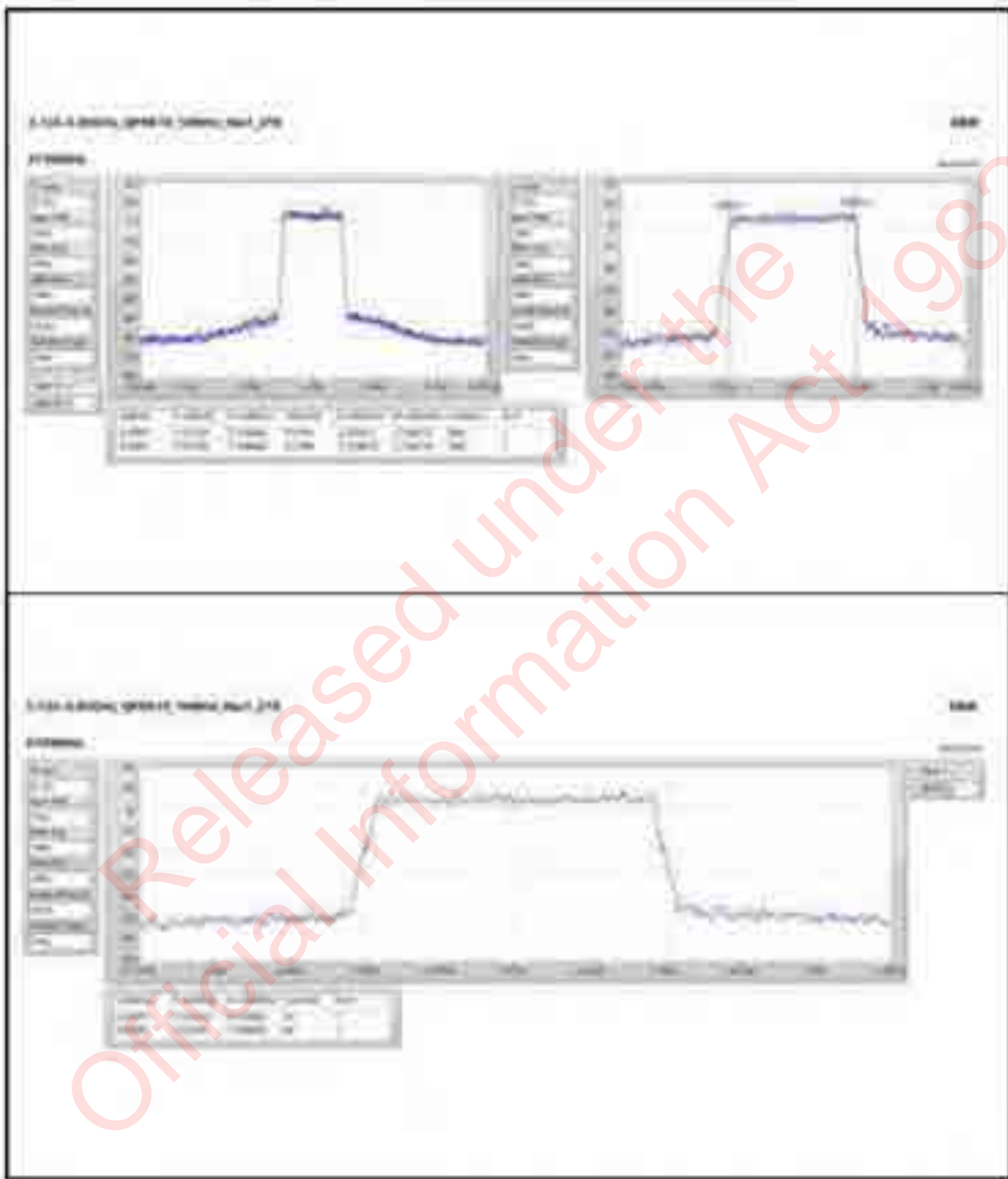

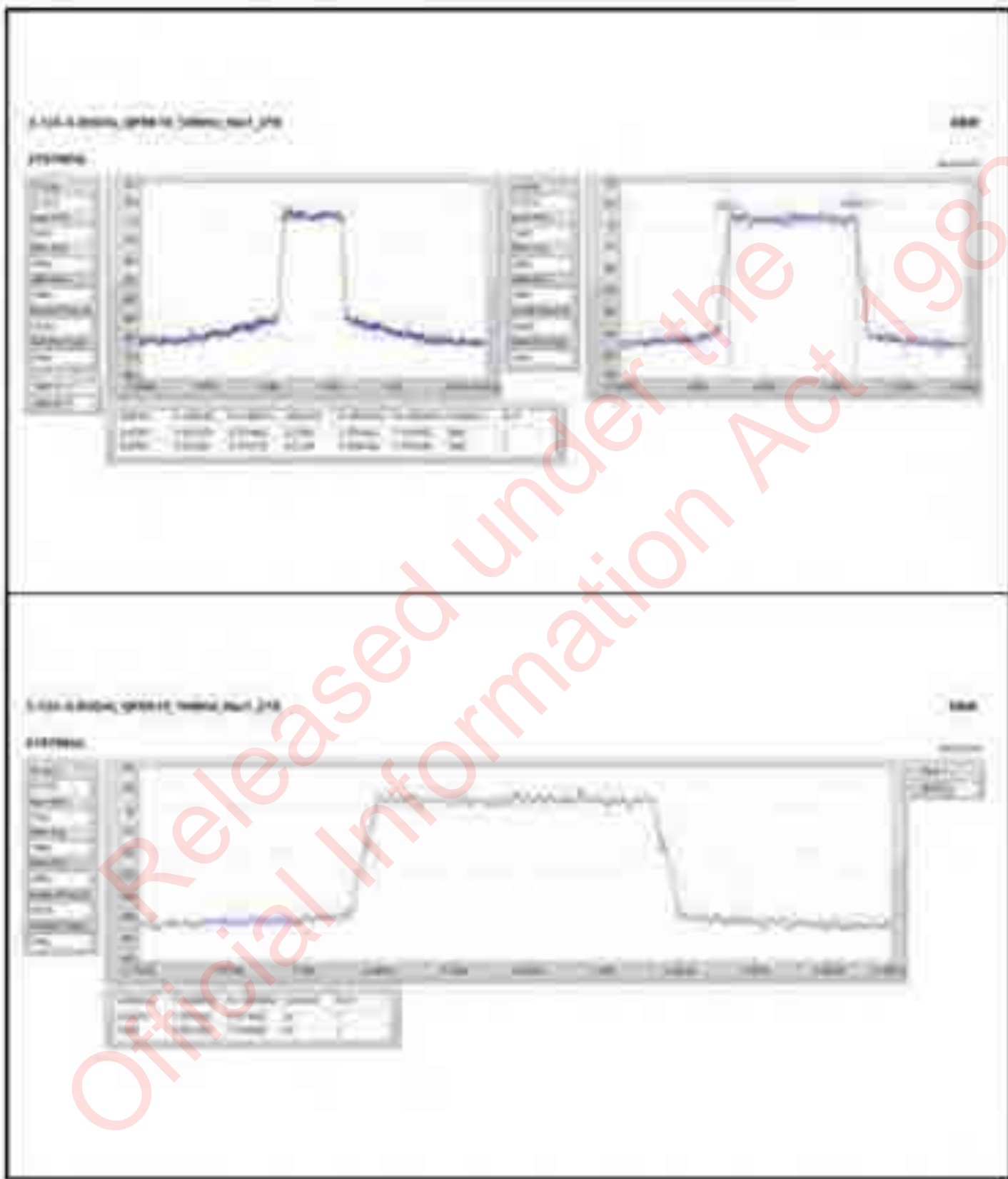

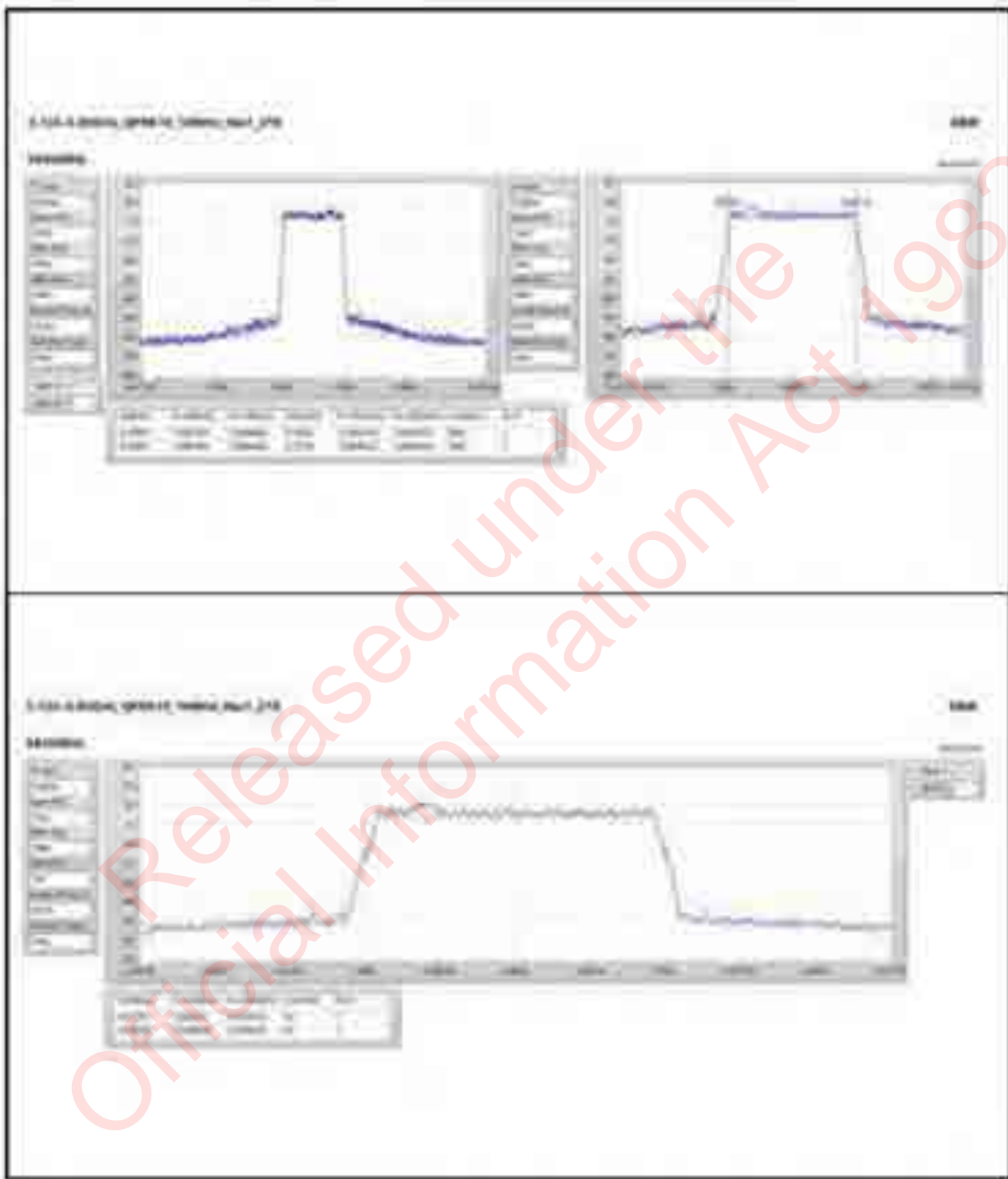

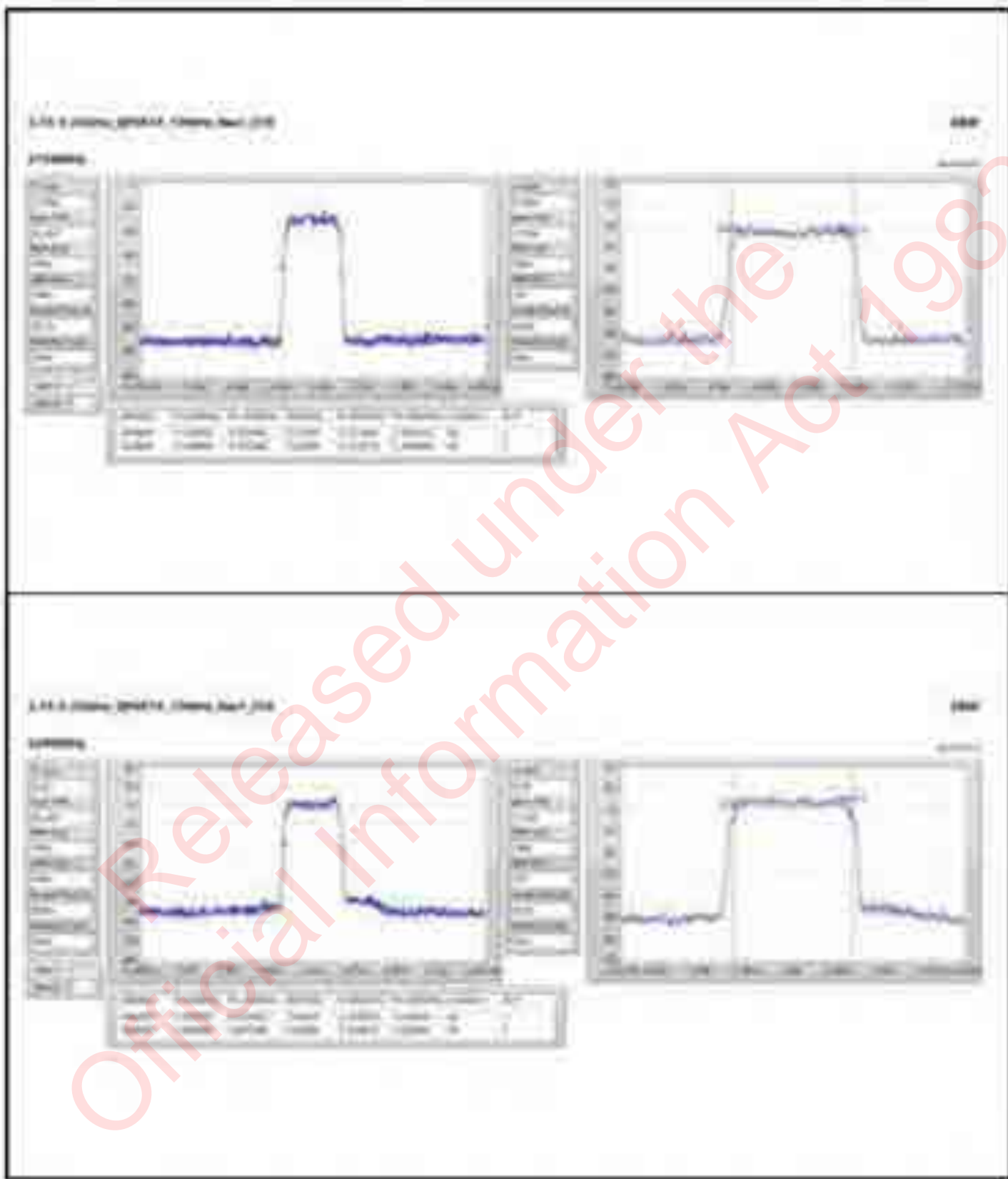

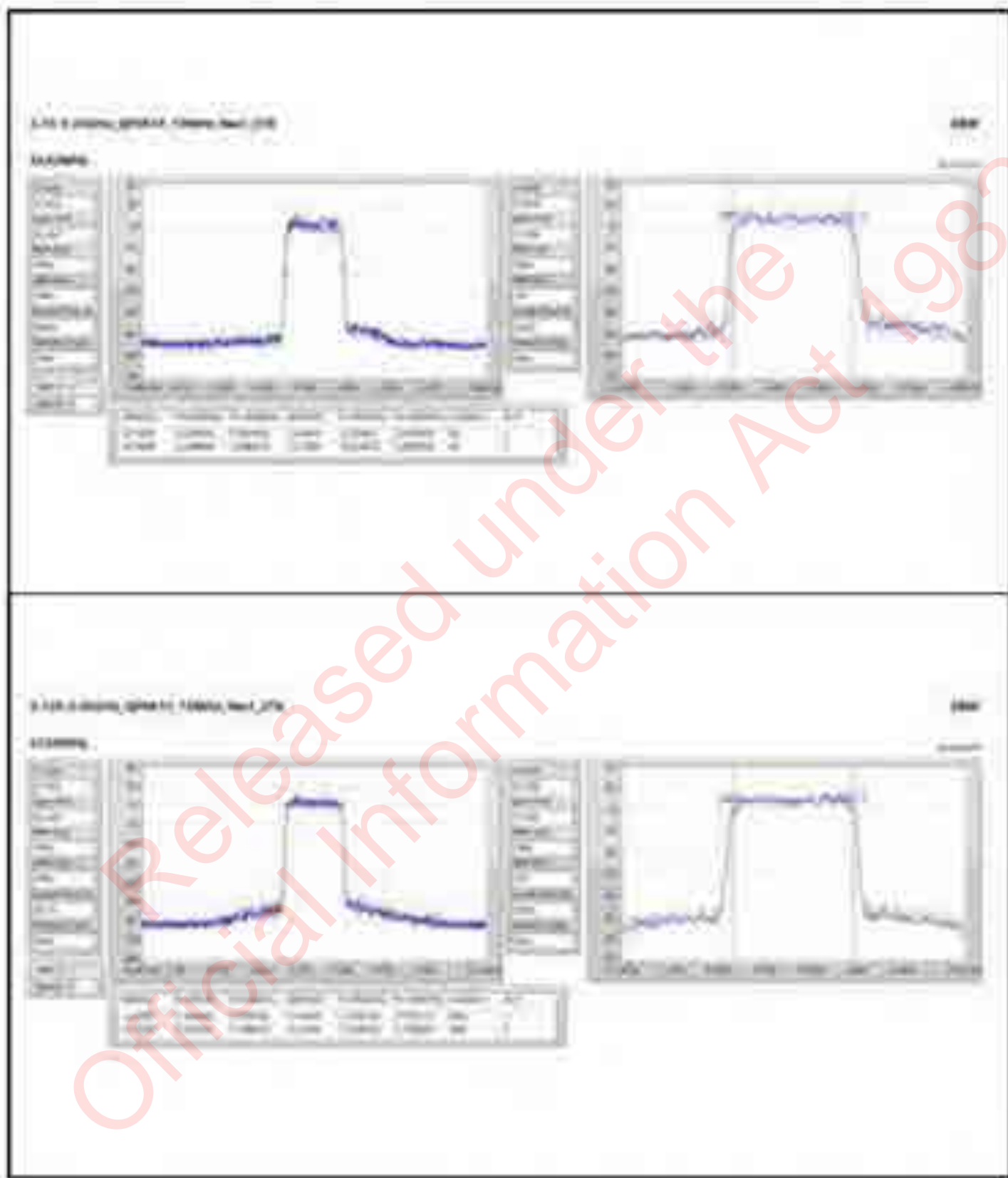

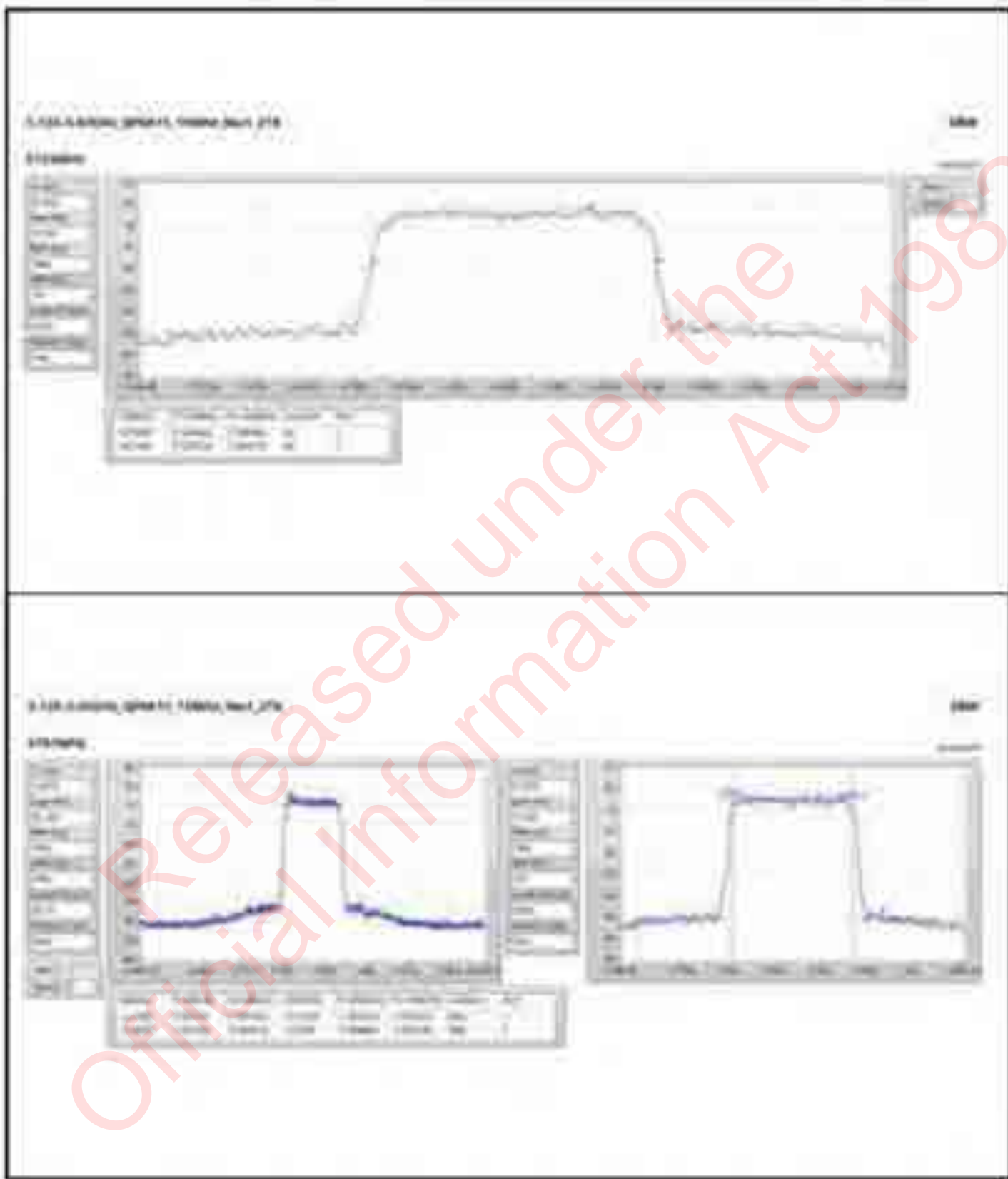

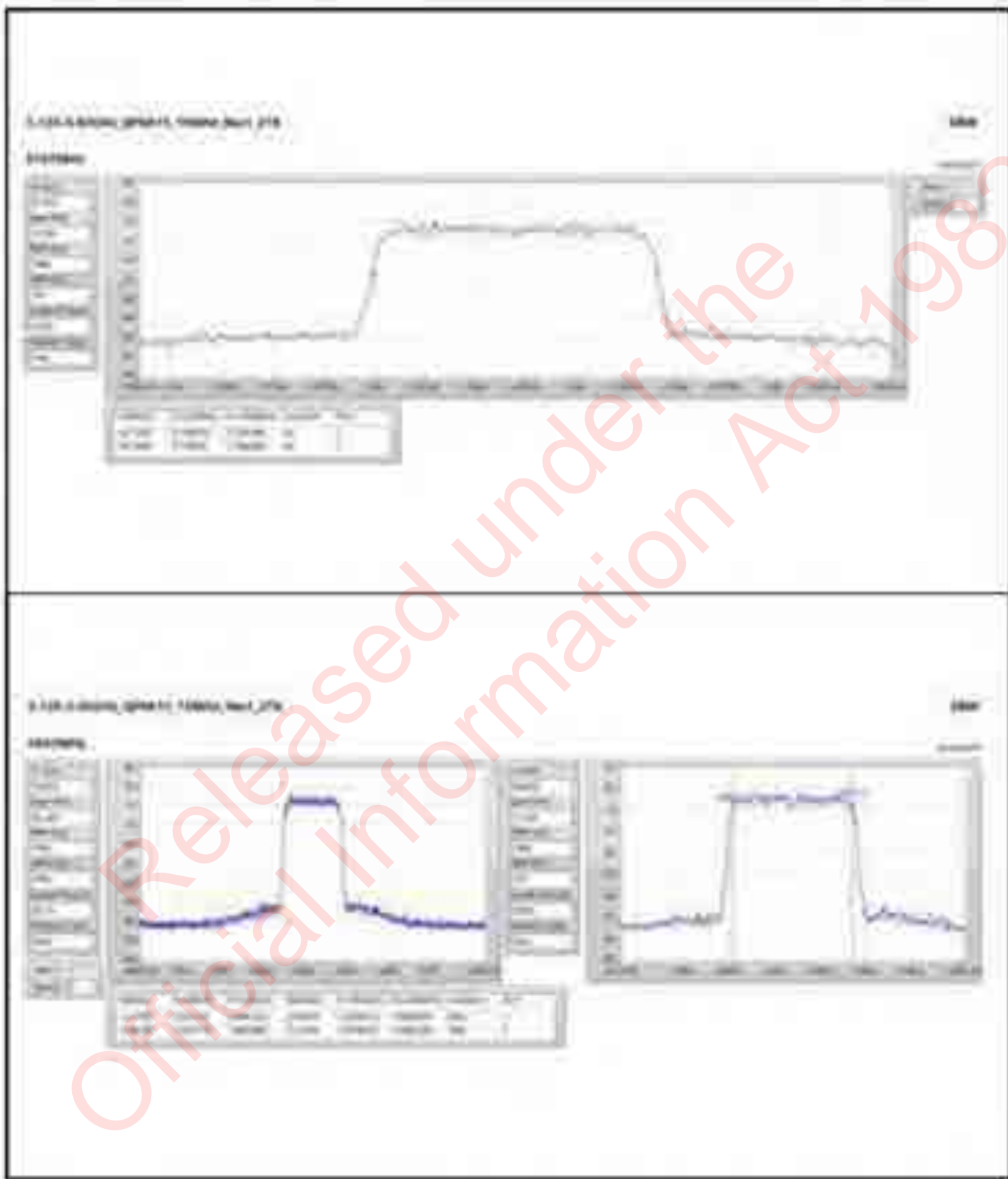

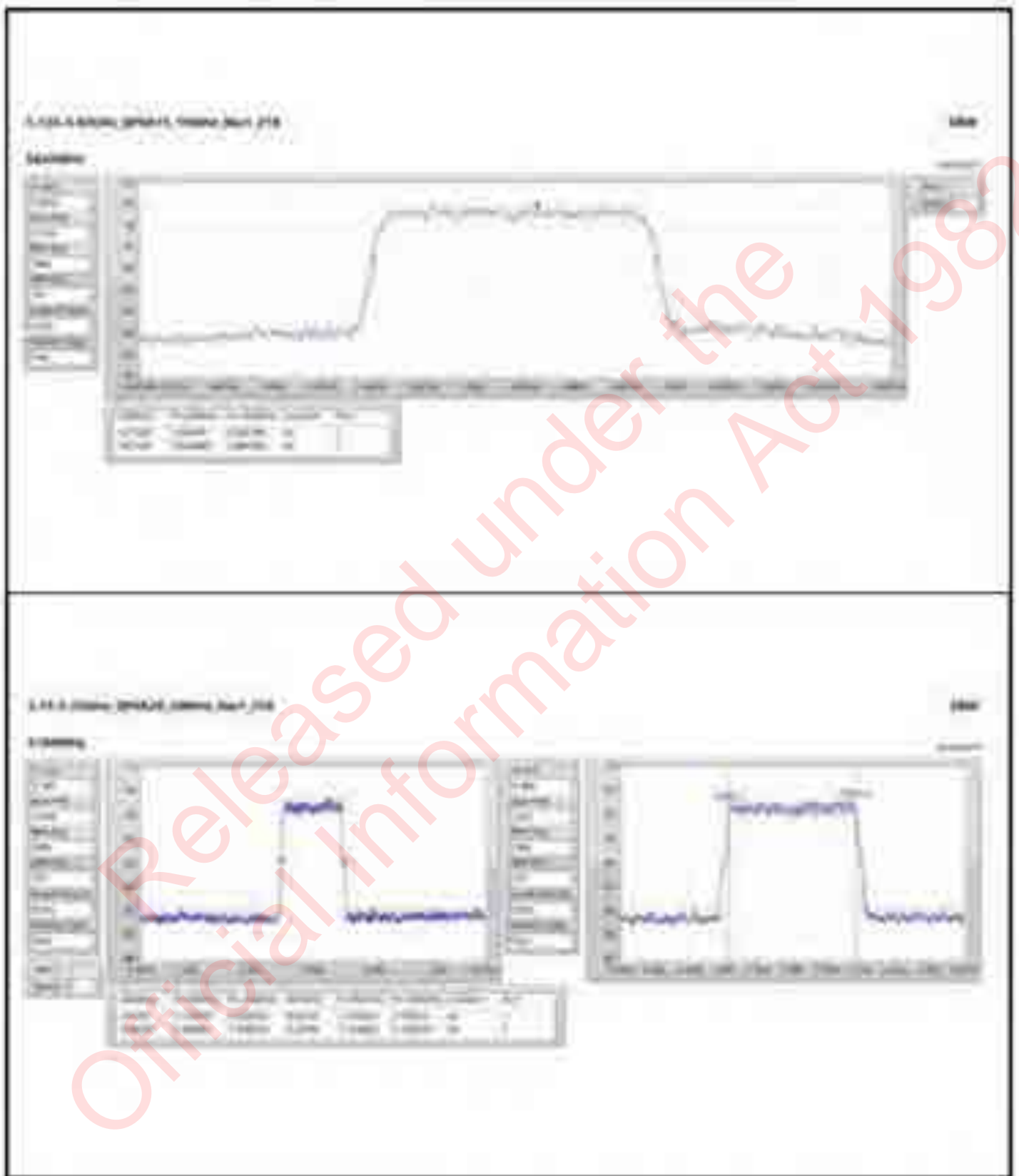

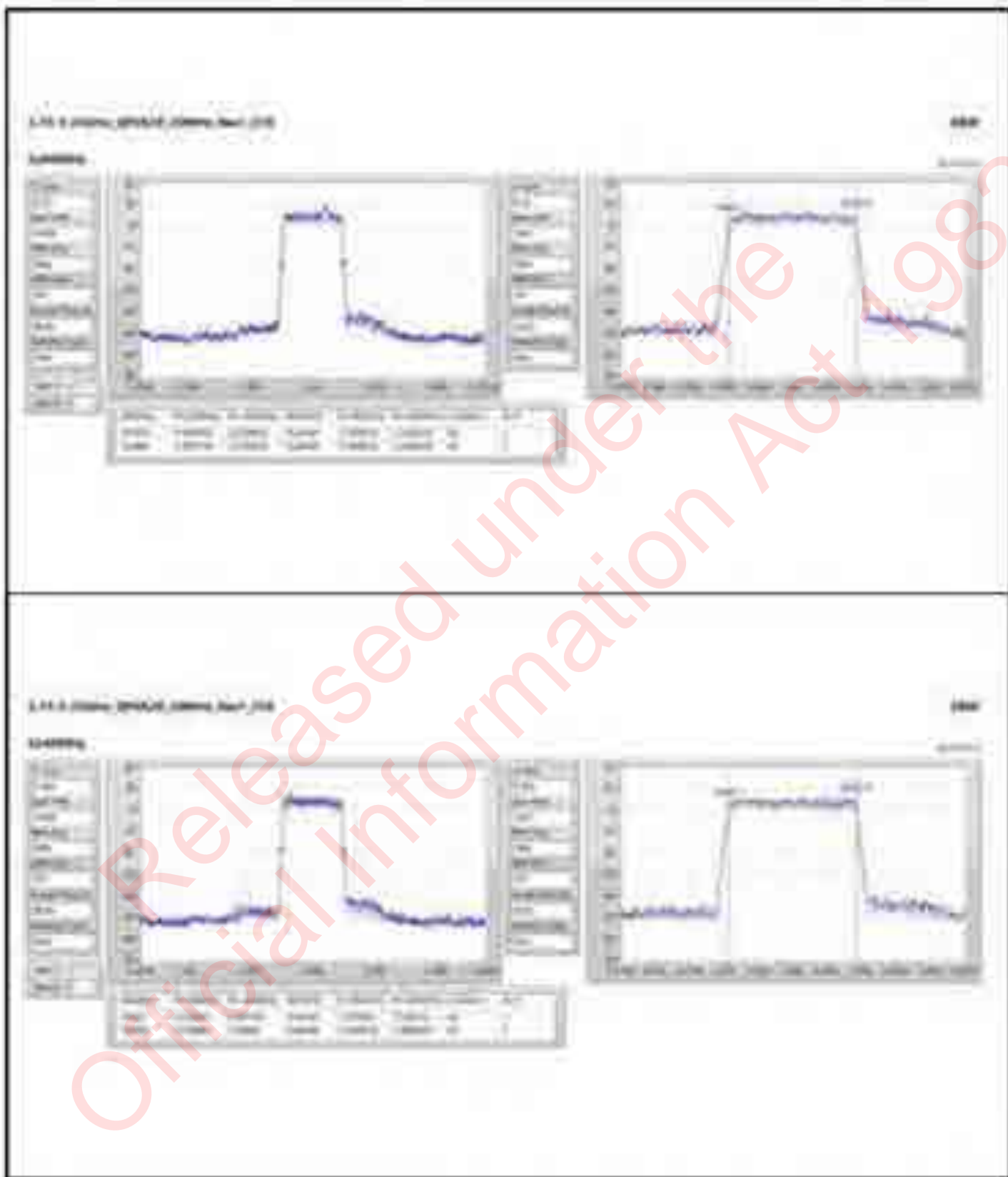

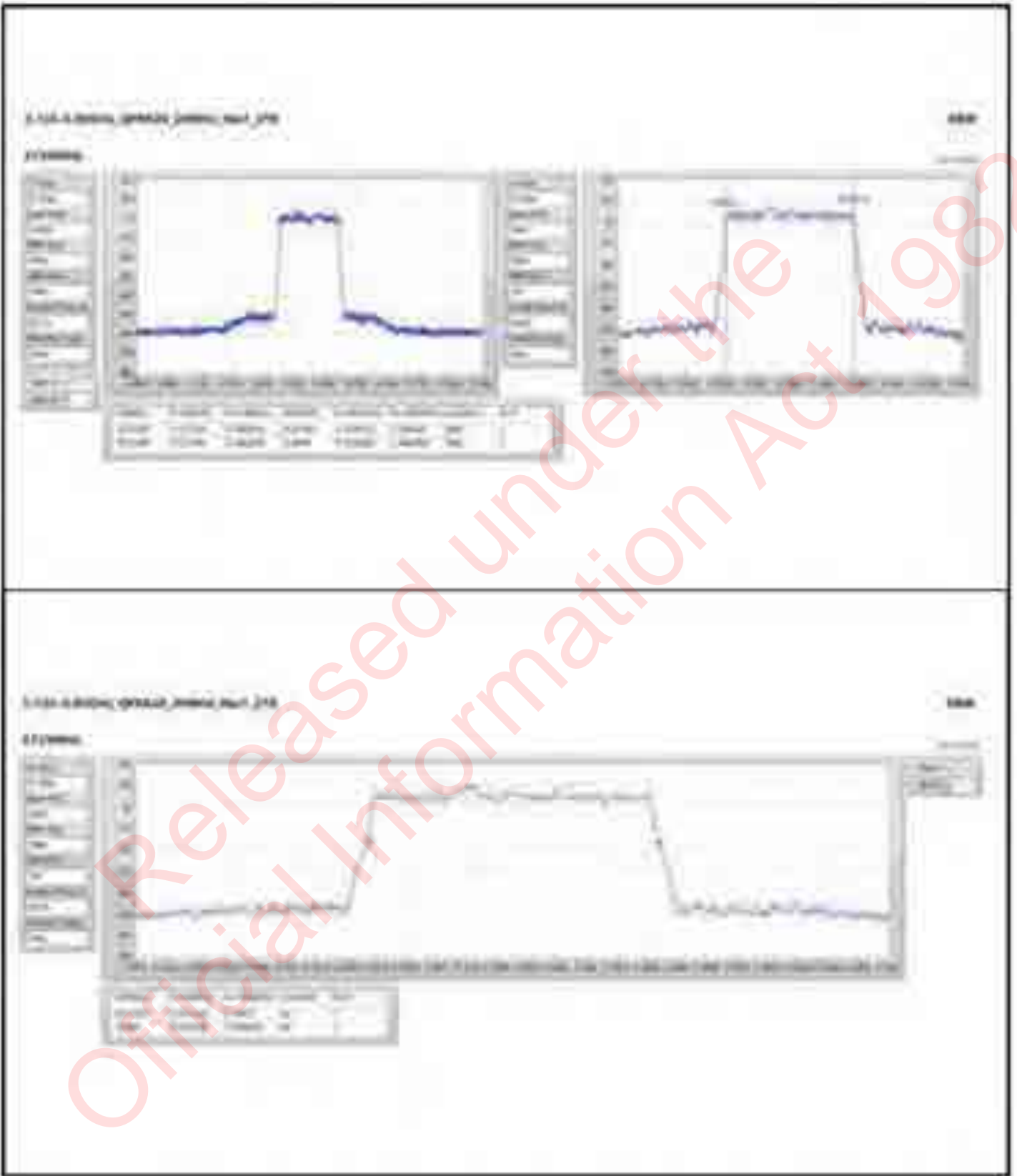



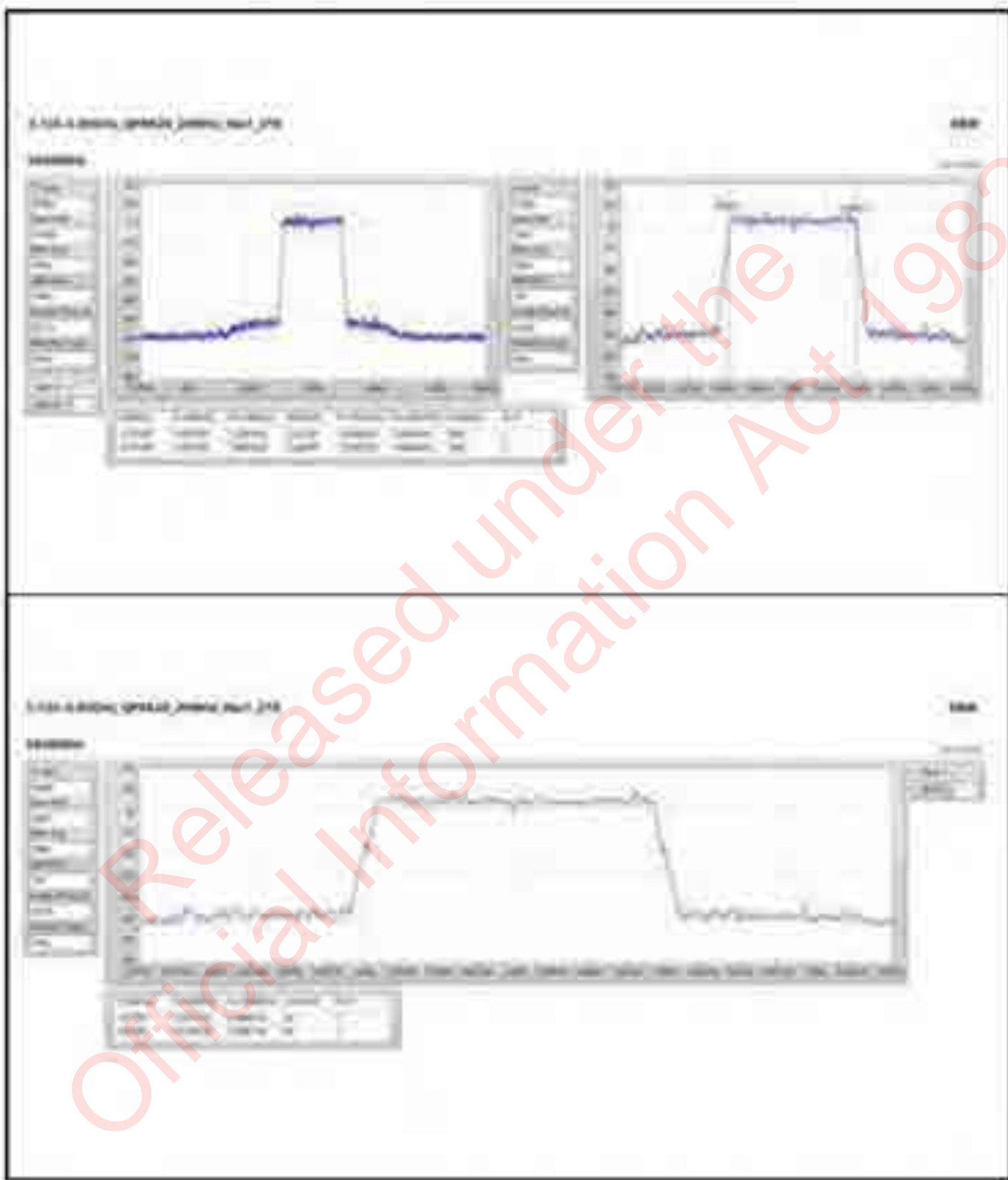

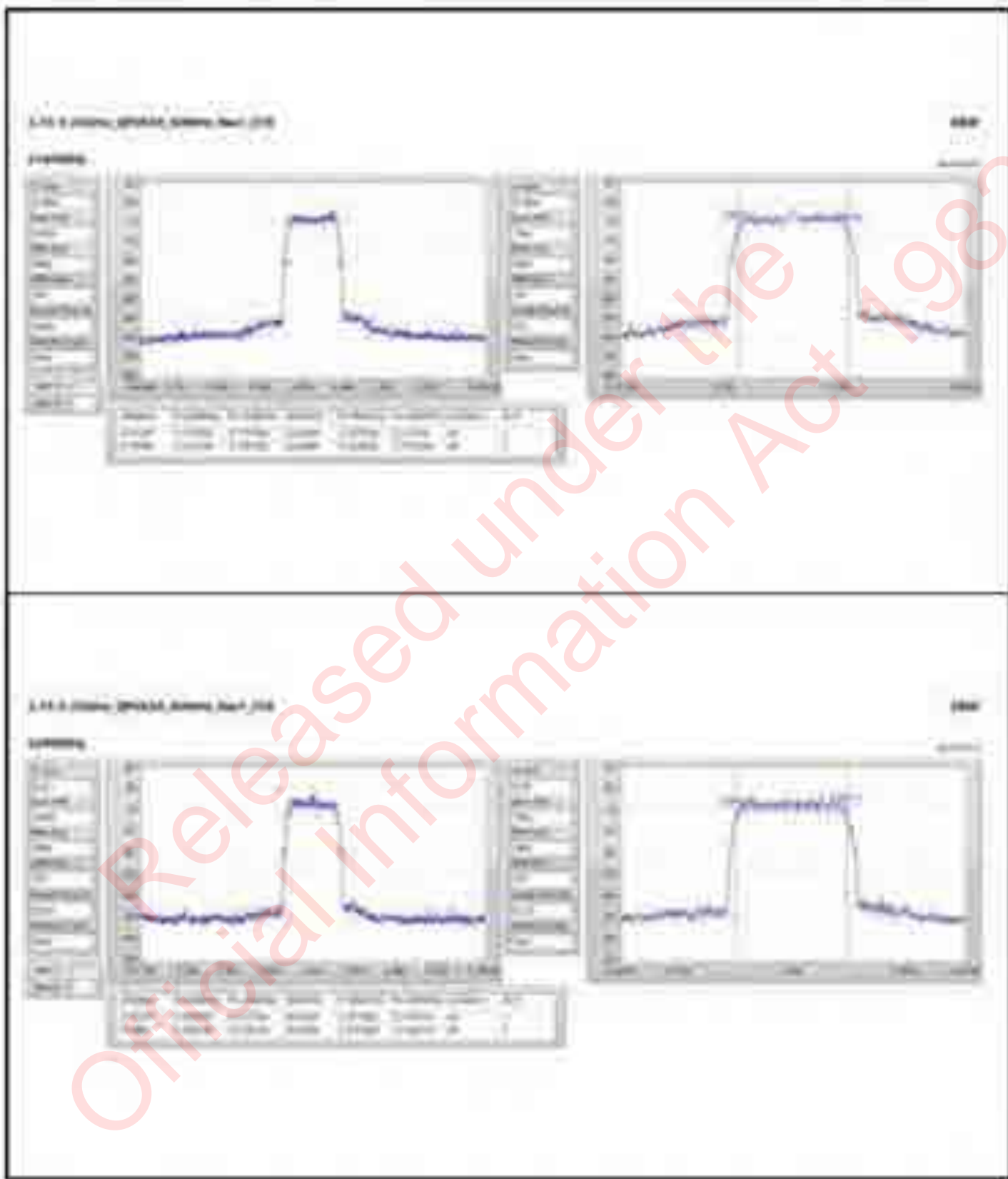

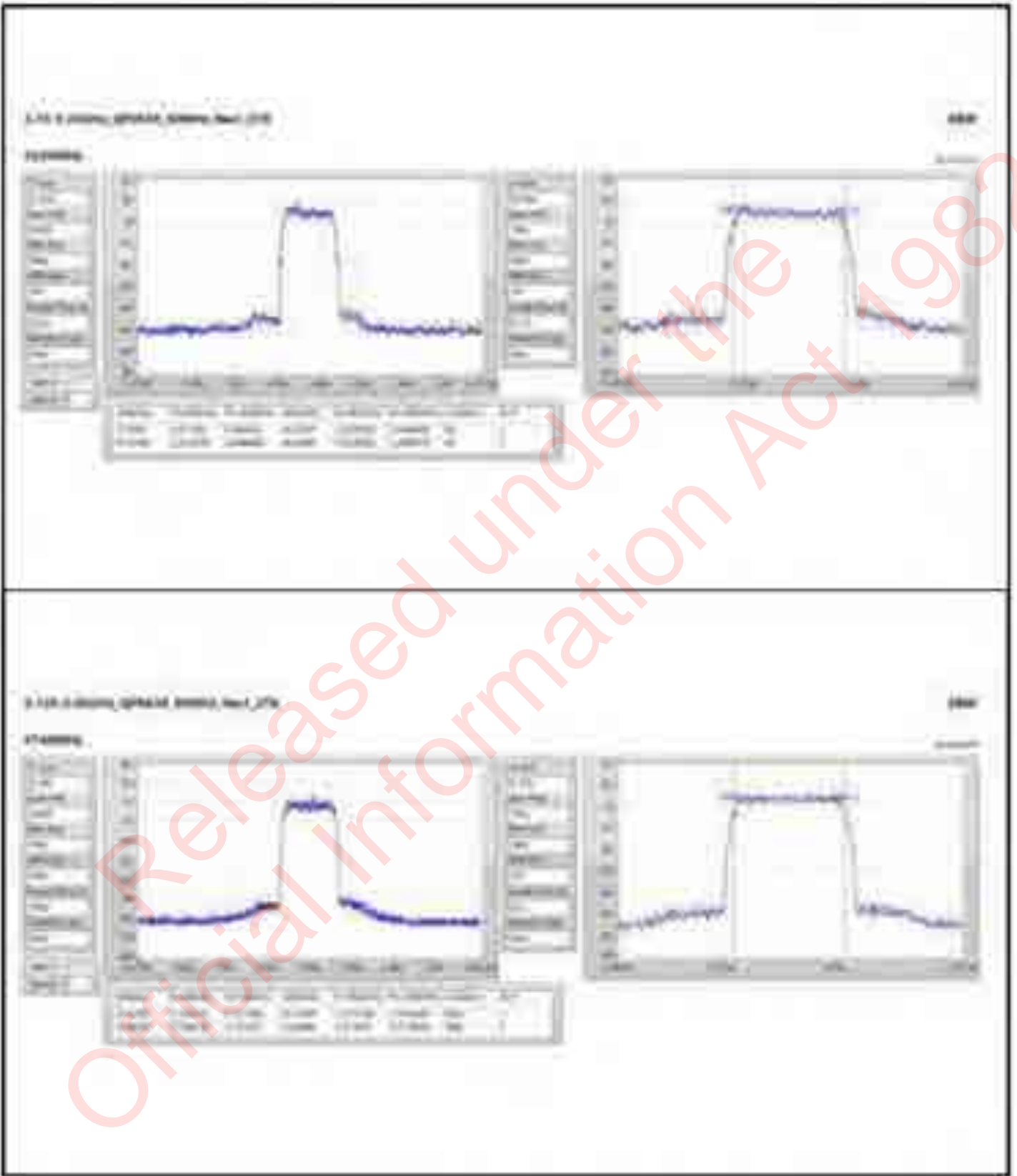

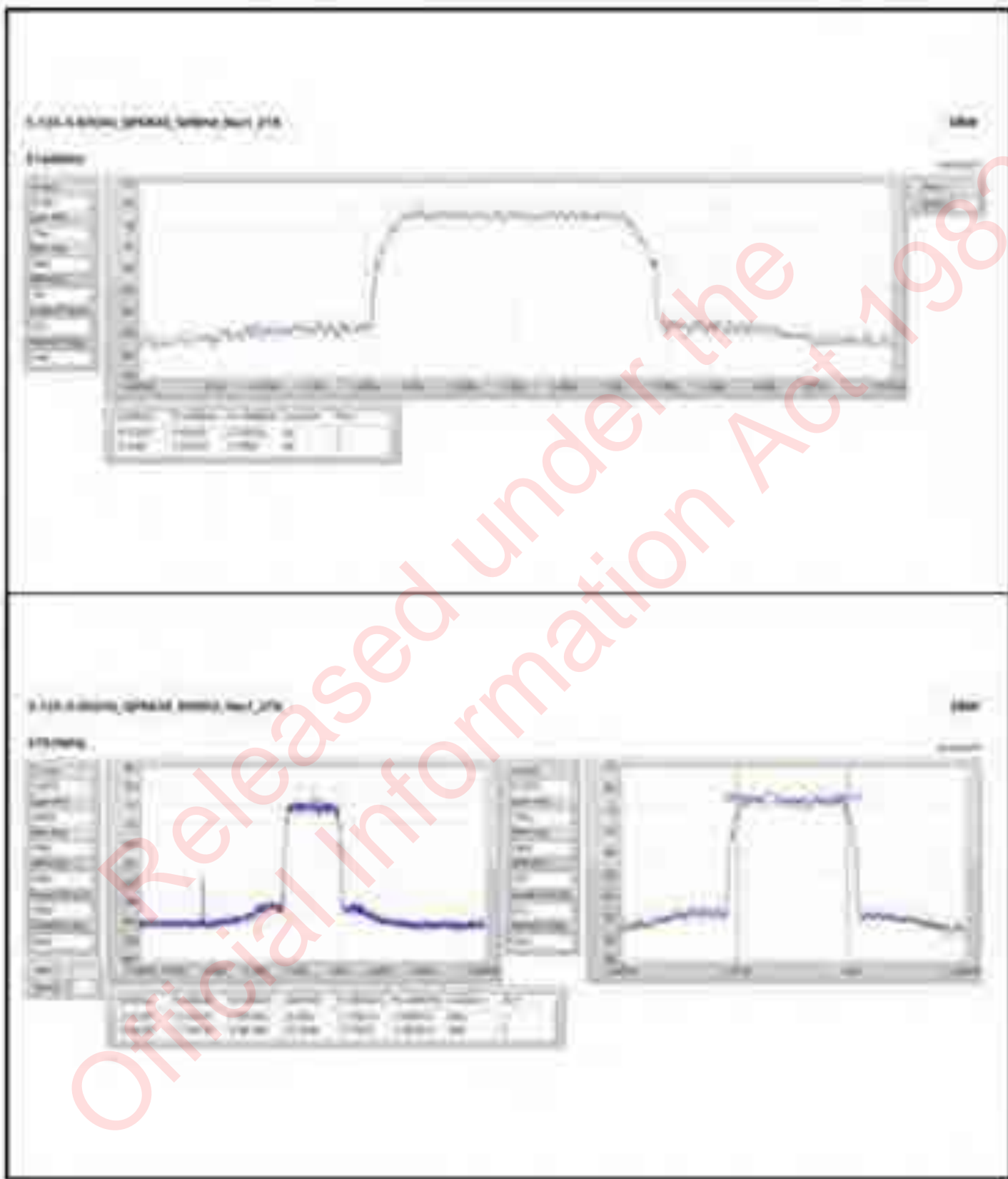

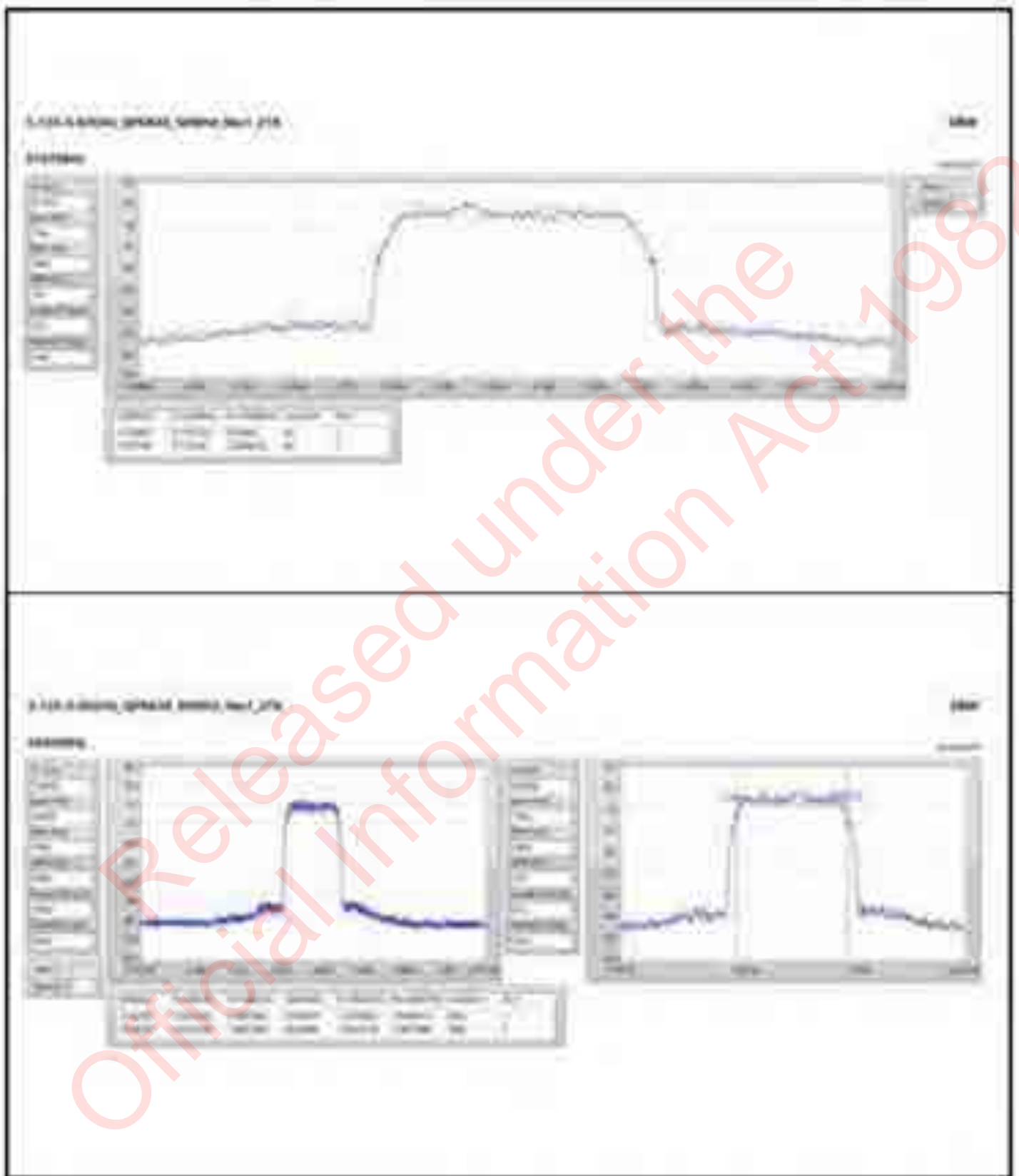

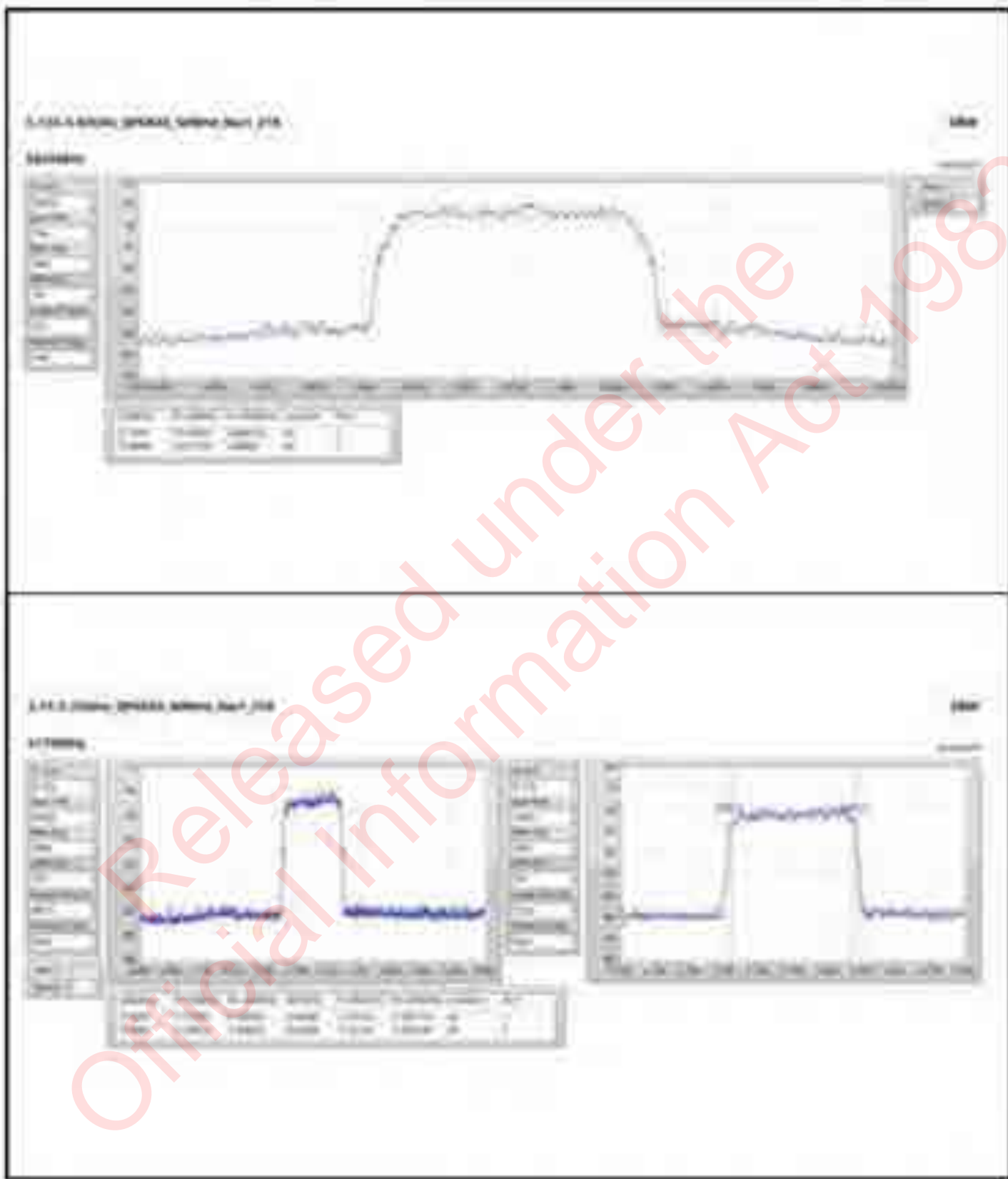

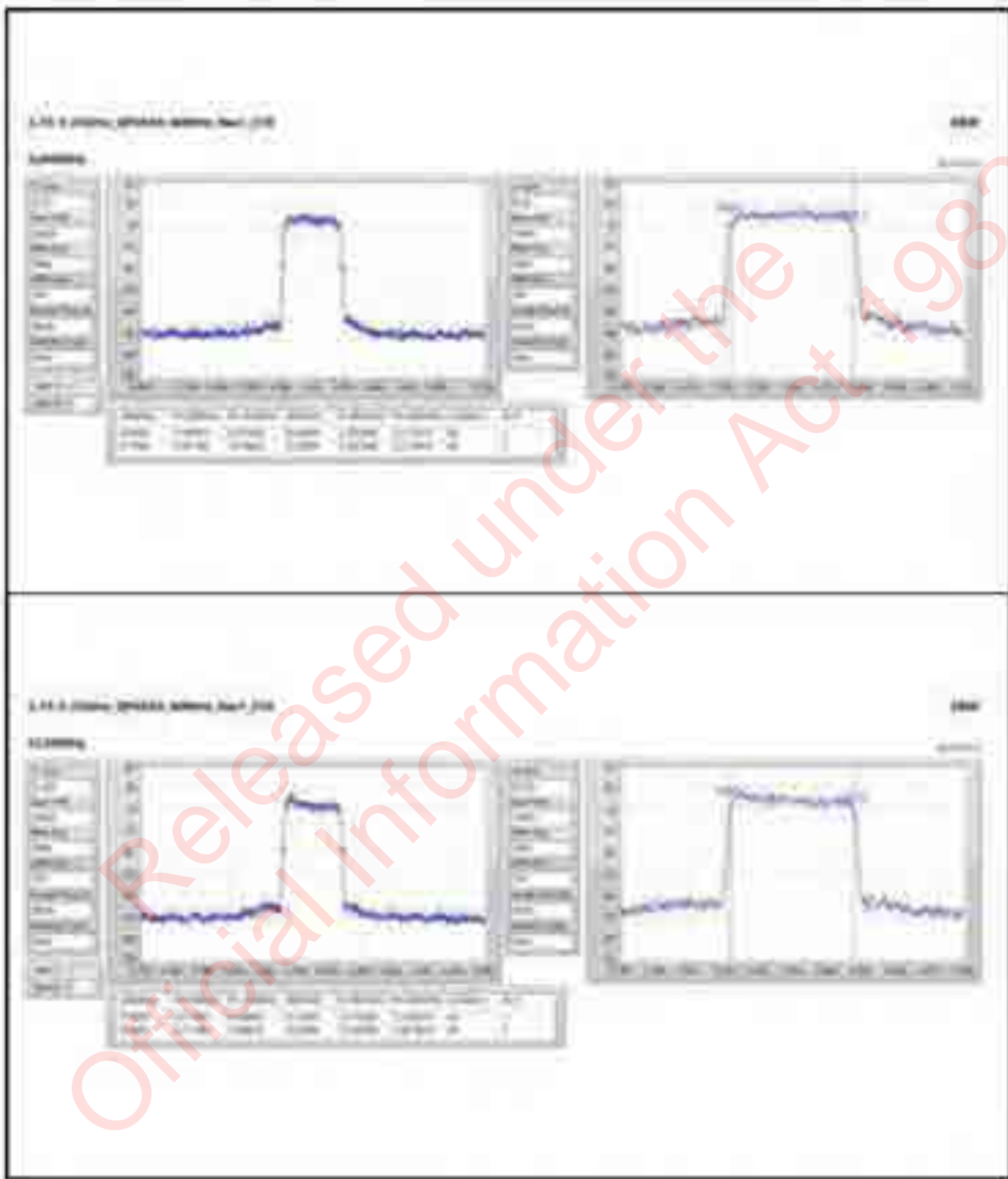

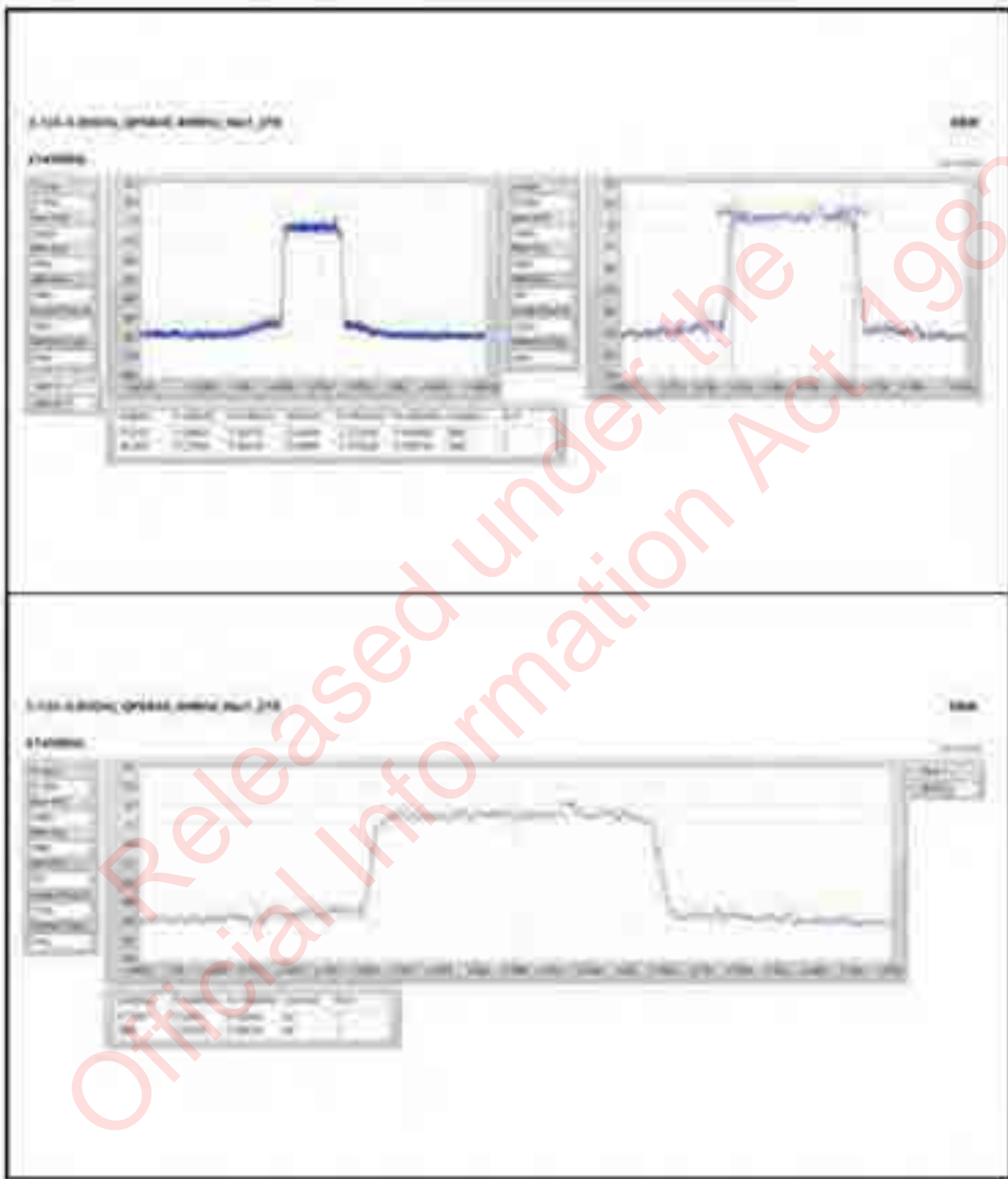

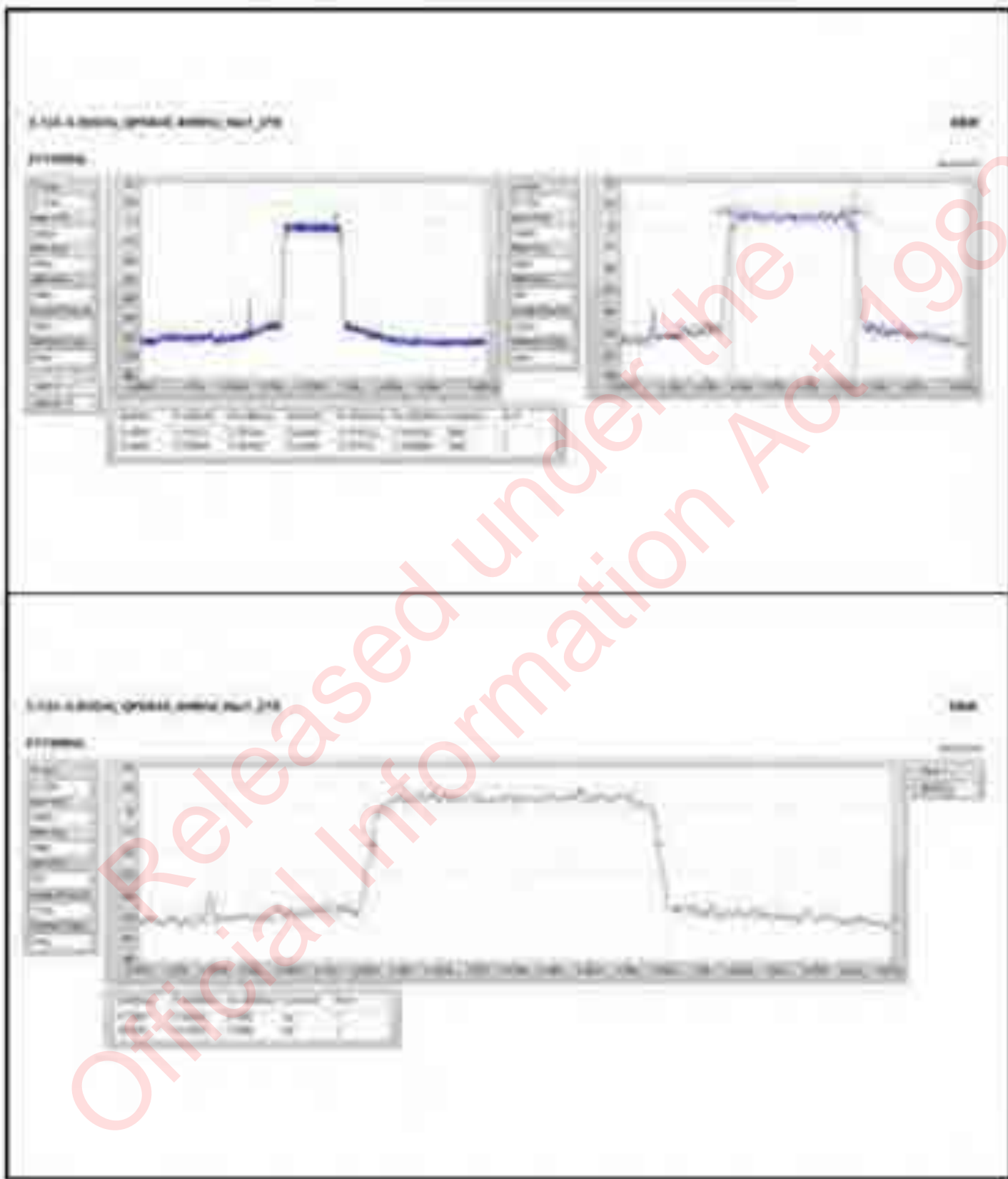

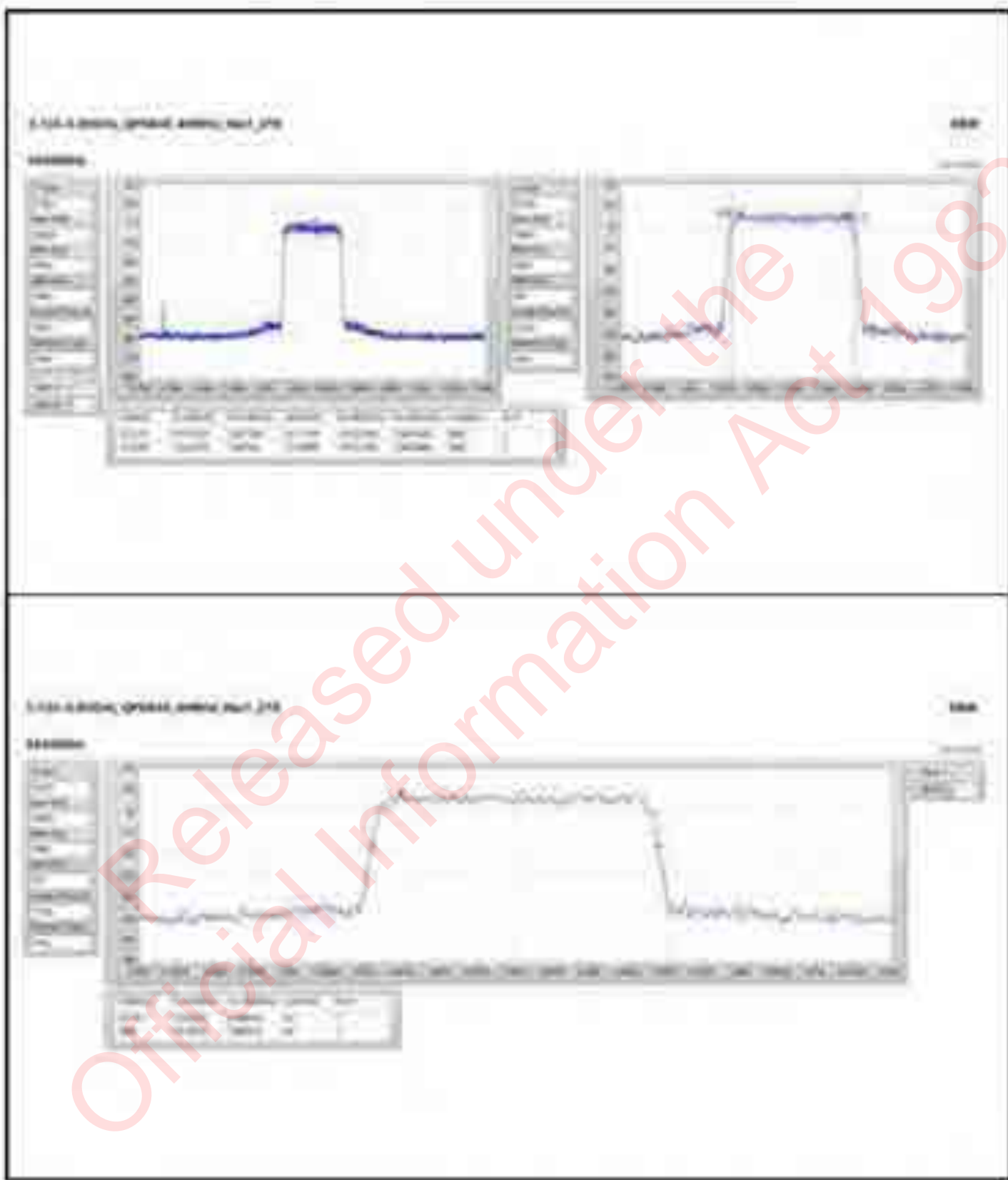



Summary

Mode	Min-Freq PdB	Max-Freq PdB	EU-Comb	Min-Freq PdB	Max-Freq PdB
1.15-1.20GHz					
OP5400-DE 2000-20000_Non_ITT777x16Pwr2	20.00M	16.44M	20Mx10	20.00M	16.44M
OP5400-DE 2000-20000_Non_ITT777x16Pwr2	21.07M	14.87M	20Mx10	21.07M	14.87M
OP5400-DE 2000-20000_Non_ITT777x16Pwr2	24.44M	15.87M	20Mx10	24.44M	15.87M
1.25-1.30GHz					
OP5400-DE 2000-20000_Non_ITT777x16Pwr2	18.00M	16.44M	18Mx10	18.00M	16.44M
OP5400-DE 2000-20000_Non_ITT777x16Pwr2	24.07M	14.88M	20Mx10	24.07M	14.88M
OP5400-DE 2000-20000_Non_ITT777x16Pwr2	21.00M	16.44M	20Mx10	21.00M	16.44M

Min-Freq - Minimum dBm power spectral density (PSD) in the frequency band
 Max-Freq - Maximum dBm power spectral density (PSD) in the frequency band
 EU-Comb - European Comb Filter
 Min-Freq - Minimum dBm power spectral density (PSD) in the frequency band
 Max-Freq - Maximum dBm power spectral density (PSD) in the frequency band

Released under the
 Official Information Act 1982



Result

Wave	Result	Unit	Freq 1-A dB	Power 1-0dB	Freq 2-A dB	Power 2-0dB	Freq 3-A dB	Power 3-0dB	Freq 4-A dB	Power 4-0dB
		dBm	GHz	dBm	GHz	dBm	GHz	dBm	GHz	dBm
CPXK3-02_20MHz_0dBm_Non_1T0P1M1P1M0	Pass	dBm	20.0100	20.010M	20.010M	20.010M	20.010M			
PT0000U_L20MHz_0.0000M_0.0000M	Pass	dBm	20.0100	20.010M	20.010M	20.010M	20.010M			
PT0000U_R20MHz_0.0000M_0.0000M	Pass	dBm	20.0100	20.010M	20.010M	20.010M	20.010M			
CPXK3-02_20MHz_0dBm_Non_1T0P1M1P1M0										
PT0000U_L20MHz_0.0000M_0.0000M	Pass	00dB					20.0100	20.010M	20.010M	20.010M
PT0000U_R20MHz_0.0000M_0.0000M	Pass	00dB					20.0100	20.010M	20.010M	20.010M
CPXK3-02_20MHz_0dBm_Non_1T0P1M1P1M0										
PT0000U_L20MHz_0.0000M_0.0000M	Pass	dB	27.0100	27.010M	27.010M	27.010M				
PT0000U_R20MHz_0.0000M_0.0000M	Pass	dB	27.0100	27.010M	27.010M	27.010M				
CPXK3-02_20MHz_0dBm_Non_1T0P1M1P1M0										
PT0000U_L20MHz_0.0000M_0.0000M	Pass	00dB					27.0100	27.010M	27.010M	27.010M
PT0000U_R20MHz_0.0000M_0.0000M	Pass	00dB					27.0100	27.010M	27.010M	27.010M
CPXK3-02_20MHz_0dBm_Non_1T0P1M1P1M0										
PT0000U_L20MHz_0.0000M_0.0000M	Pass	dB	26.0100	26.010M	26.010M	26.010M				
PT0000U_R20MHz_0.0000M_0.0000M	Pass	dB	26.0100	26.010M	26.010M	26.010M				
CPXK3-02_20MHz_0dBm_Non_1T0P1M1P1M0										
PT0000U_L20MHz_0.0000M_0.0000M	Pass	00dB					26.0100	26.010M	26.010M	26.010M
PT0000U_R20MHz_0.0000M_0.0000M	Pass	00dB					26.0100	26.010M	26.010M	26.010M

Pass/Fail - Pass/Fail according to 37.101.1000 test method according to standard
 Pass/0dBm - Not 0dBm power level

Released under the
 Official Information Act 1982

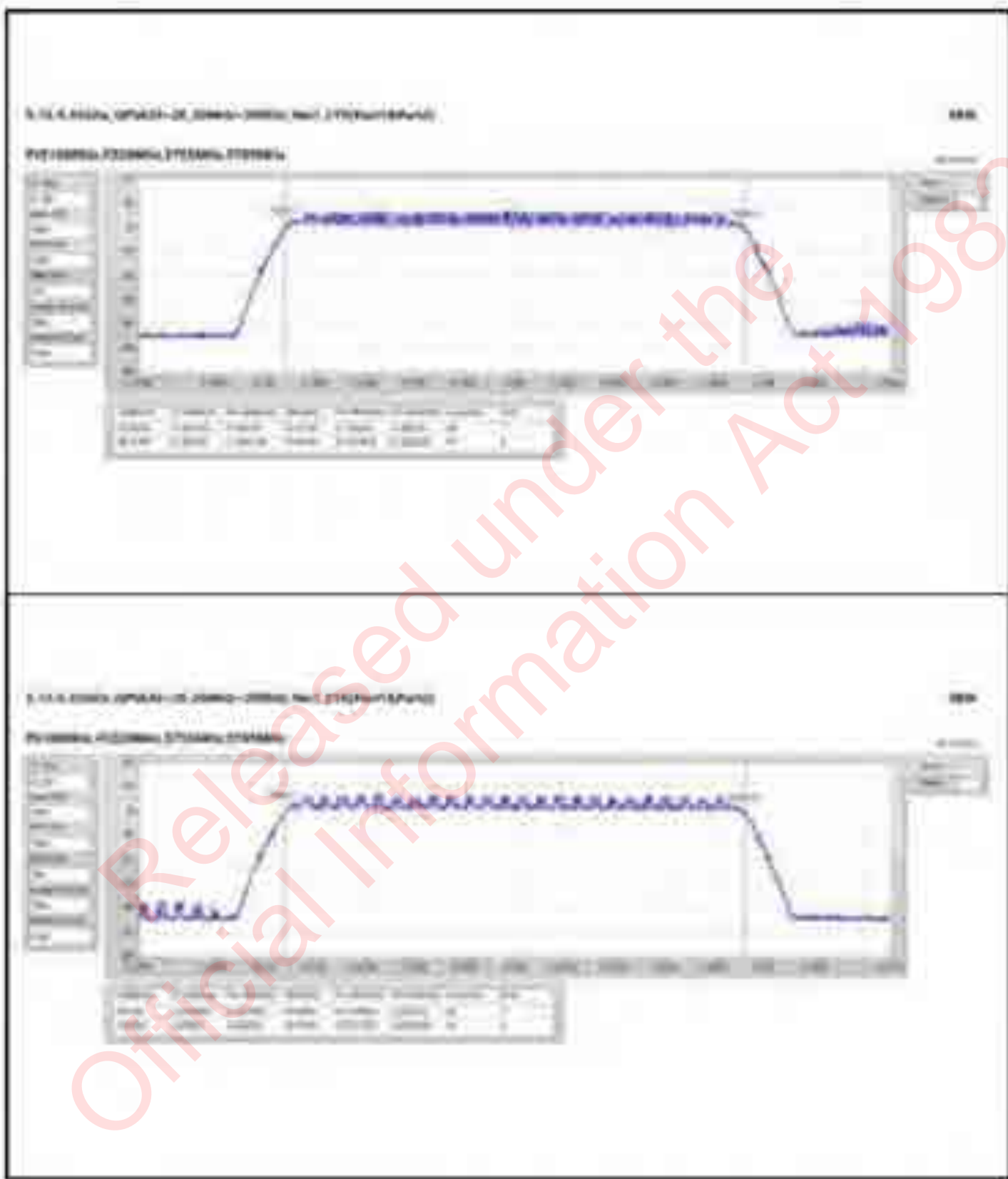

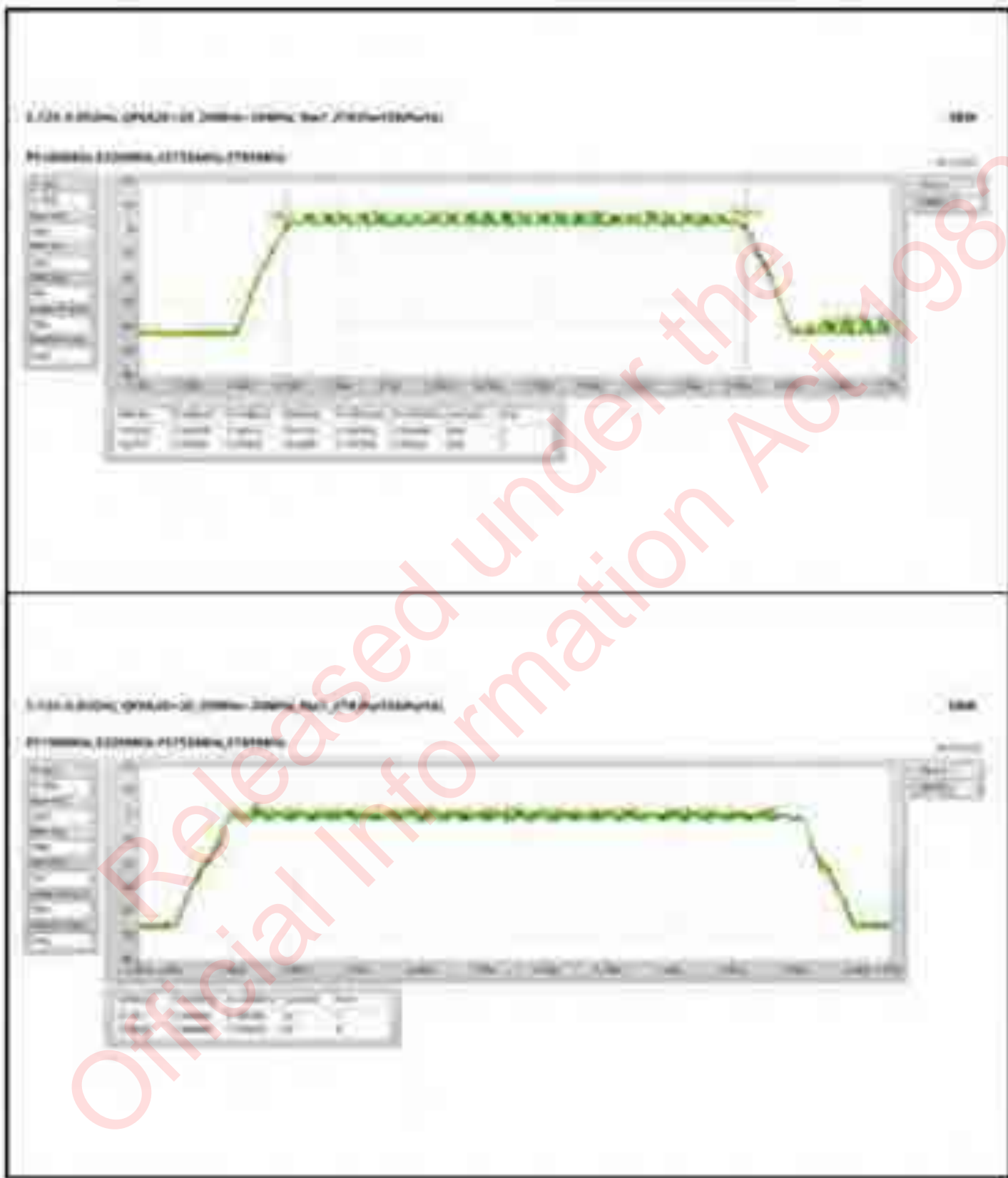

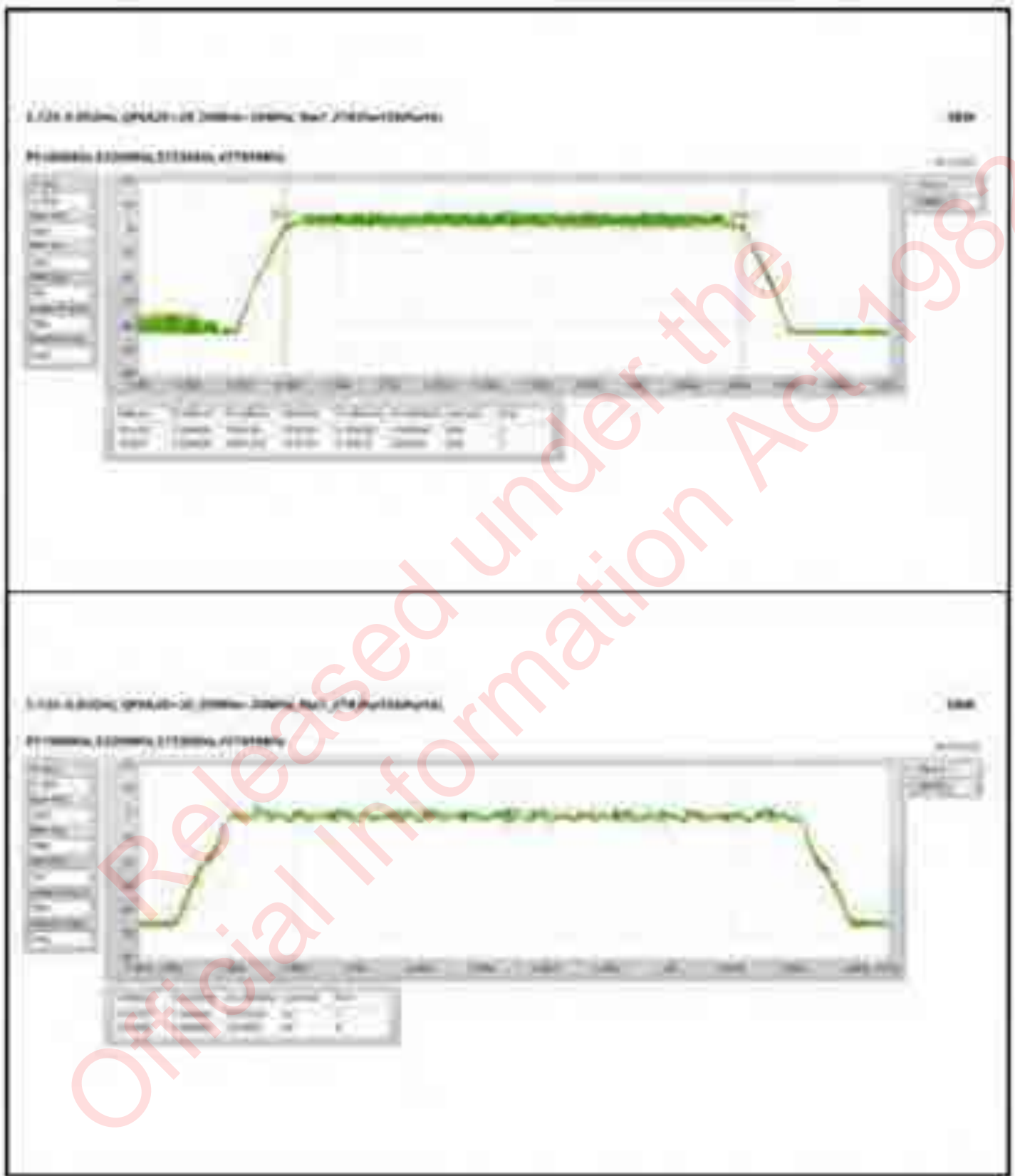

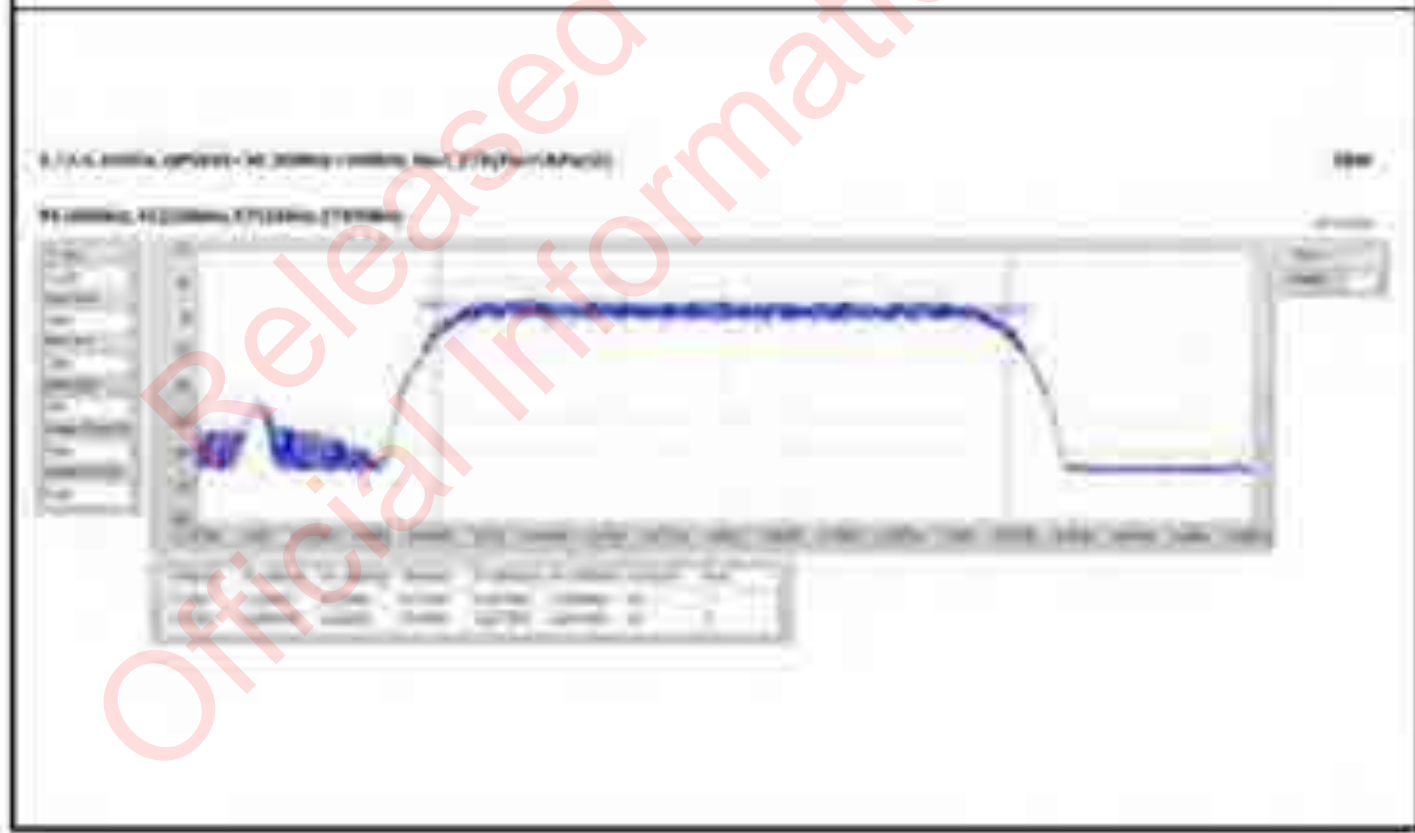
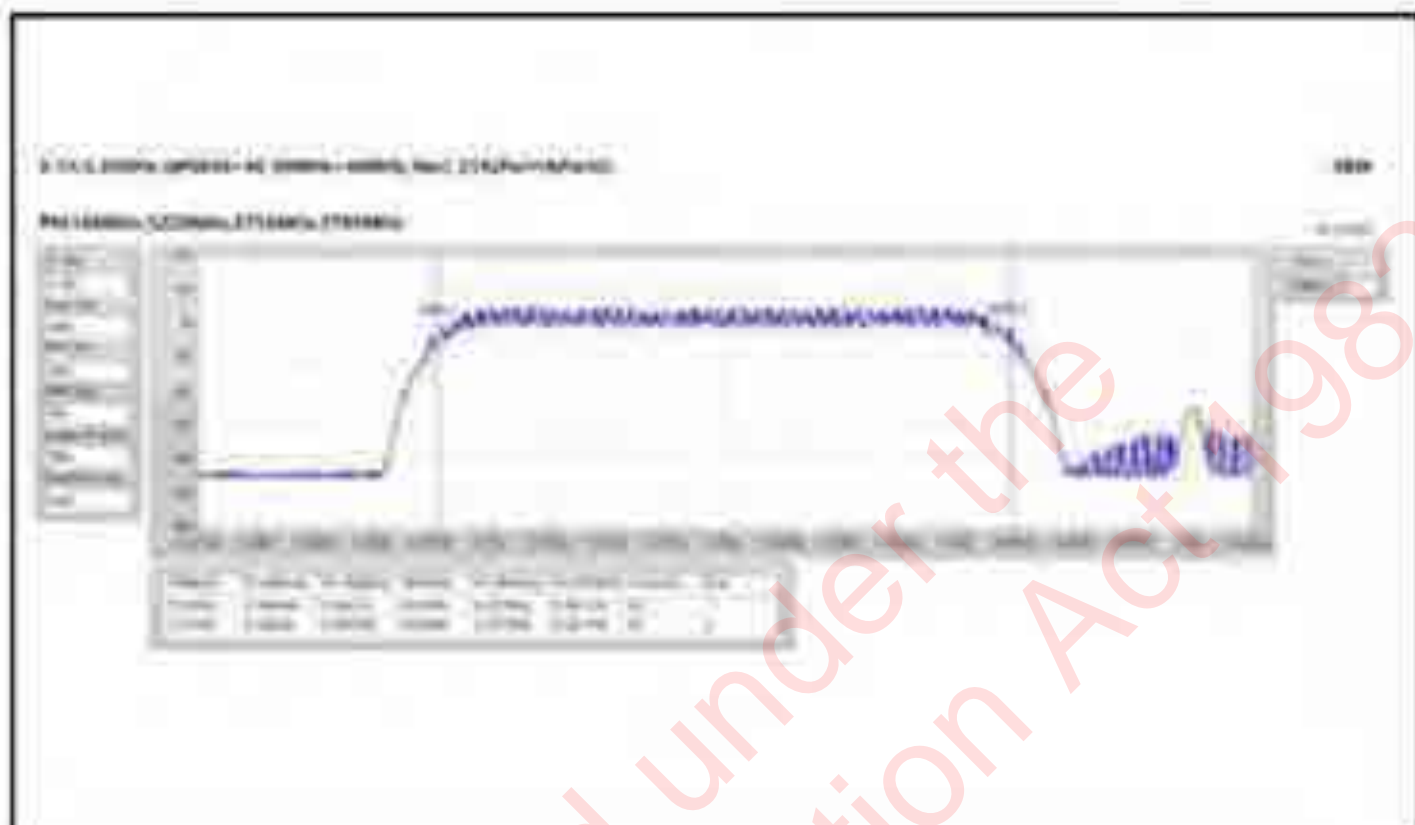

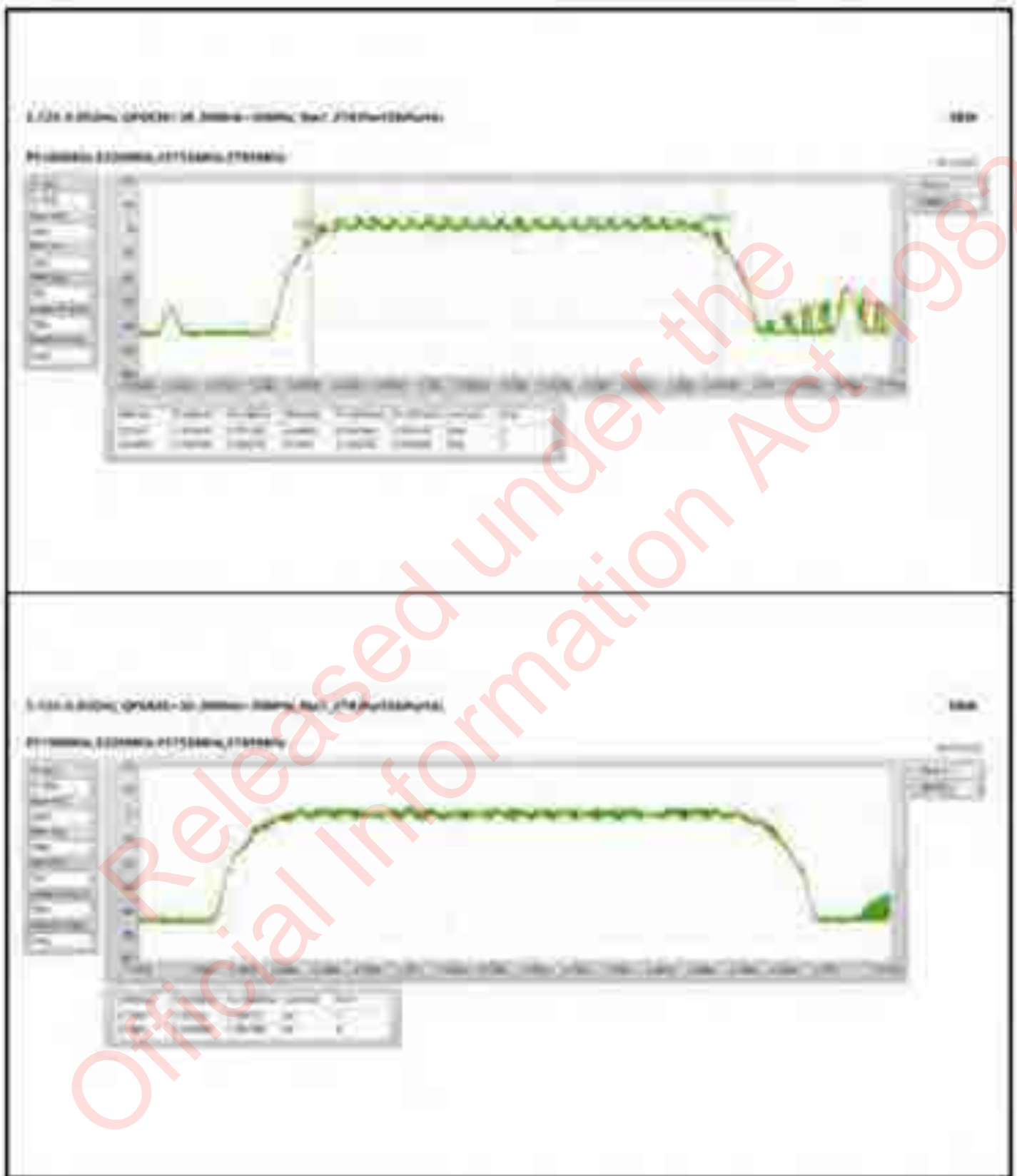

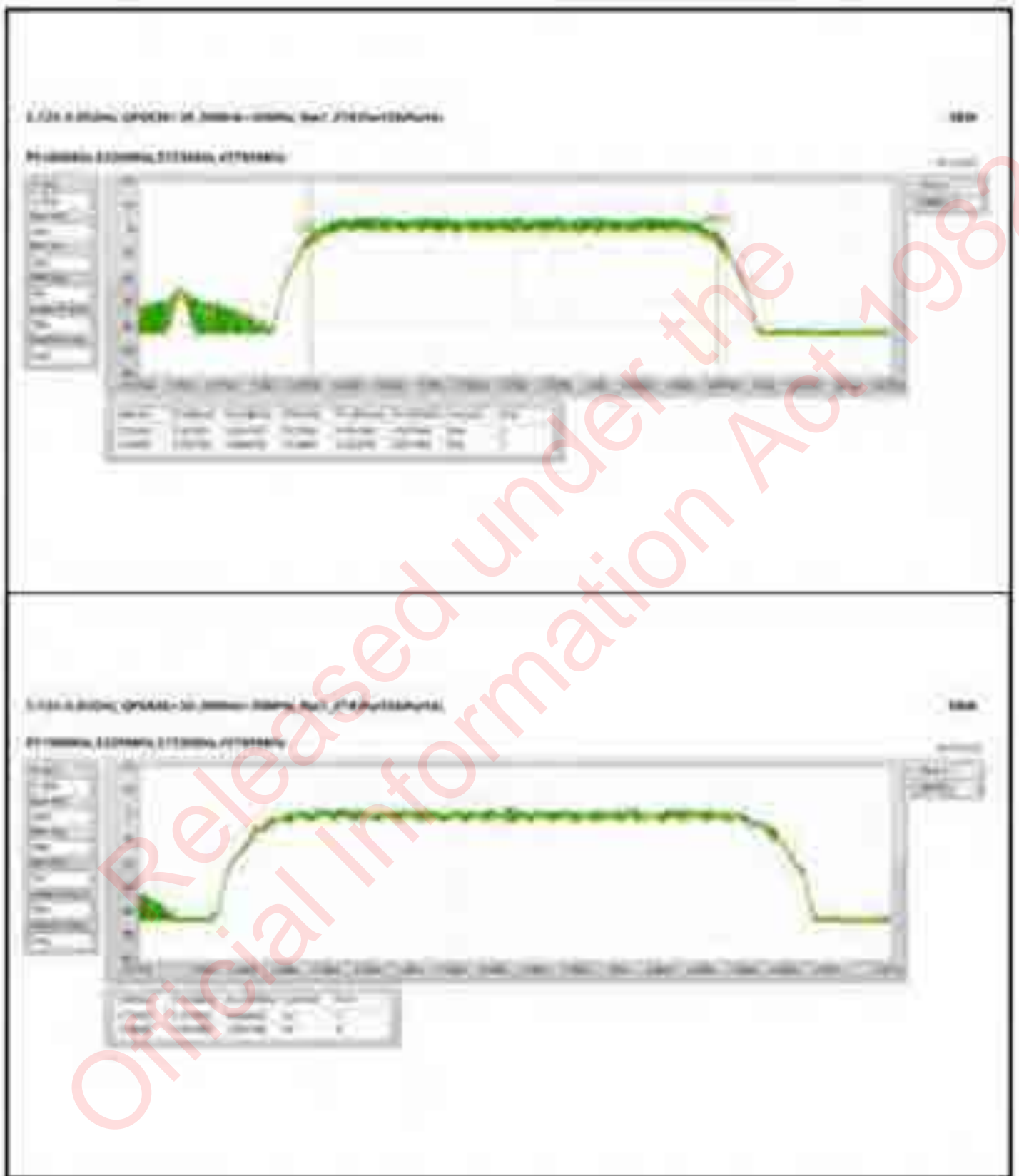

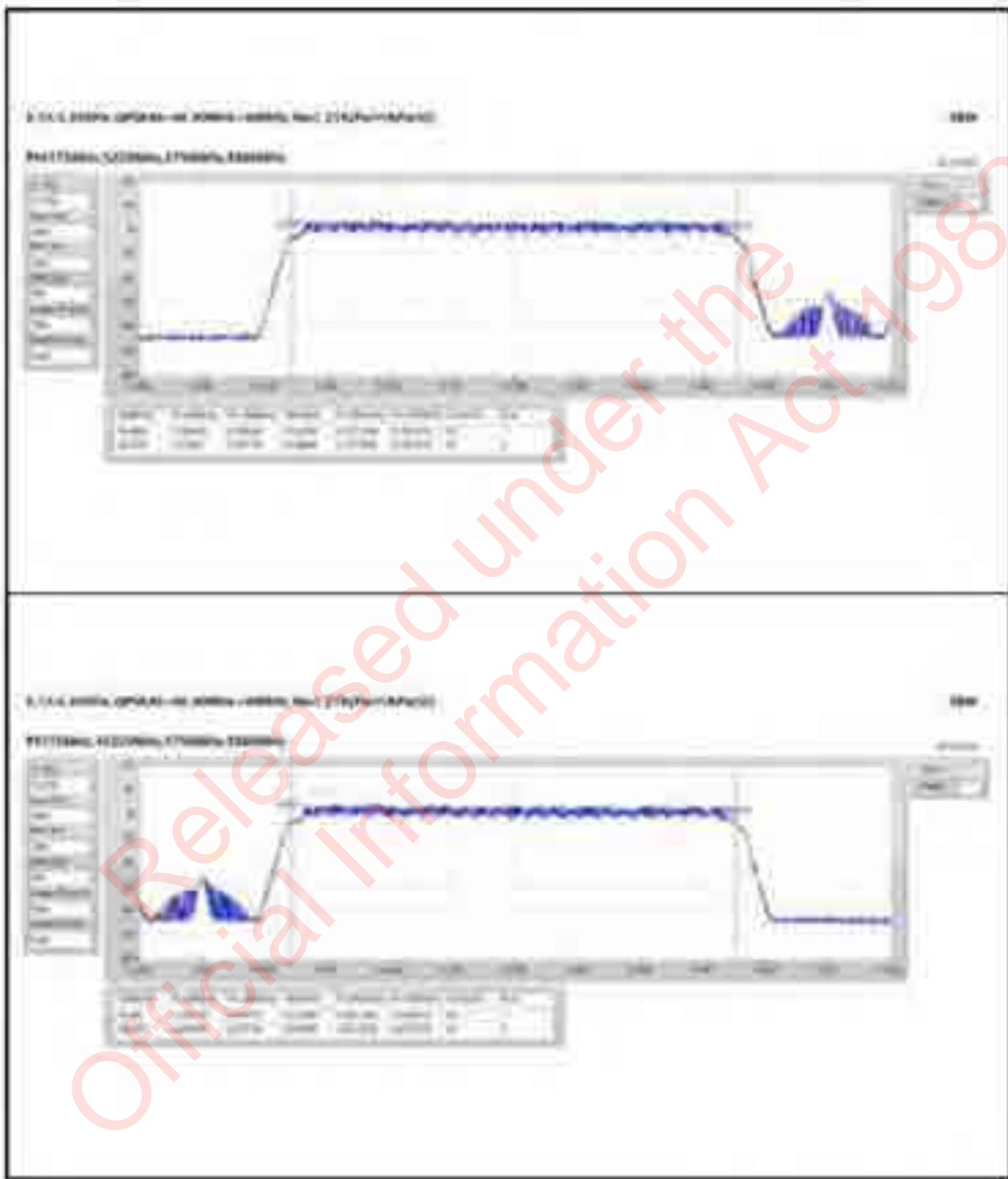

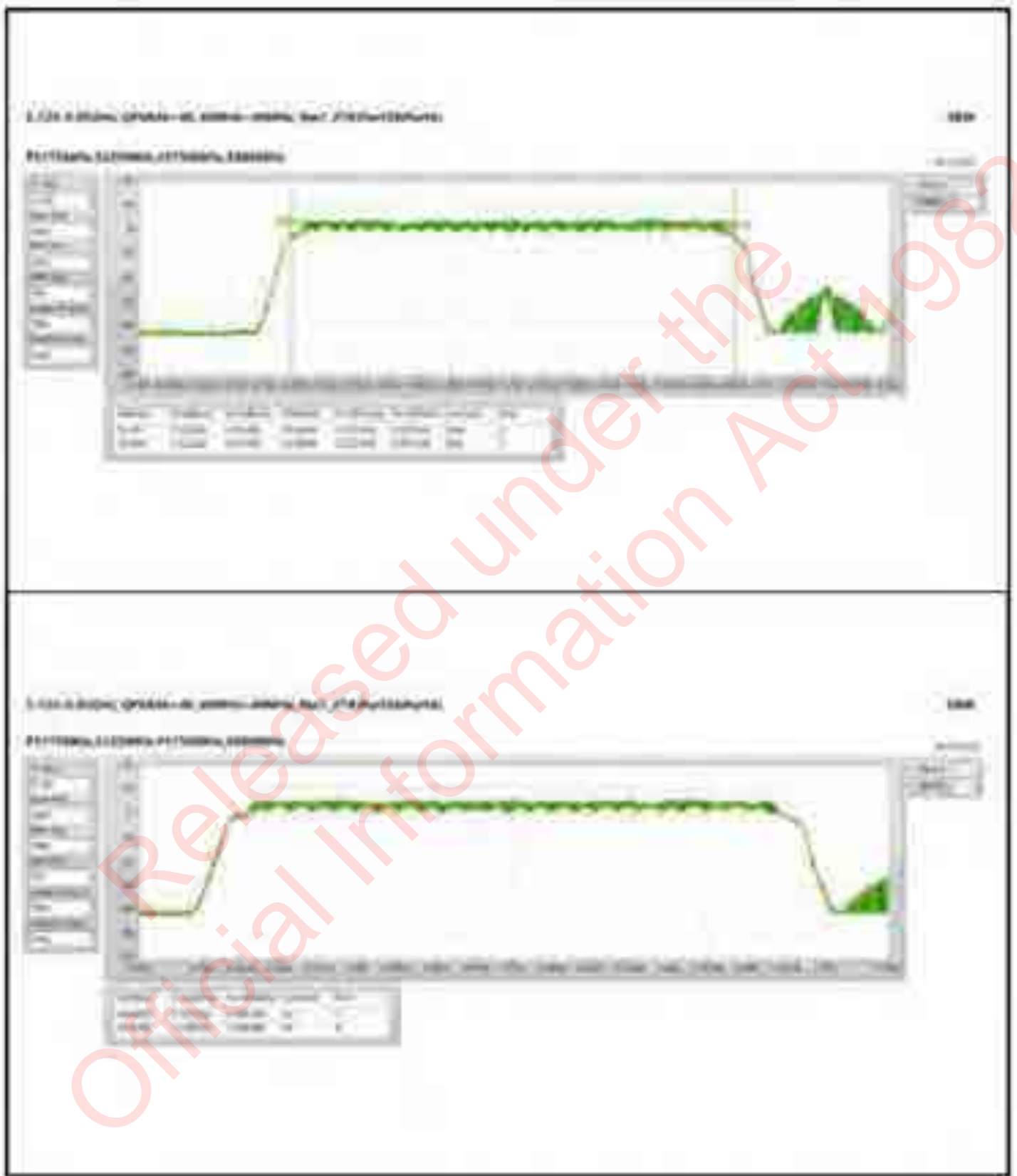

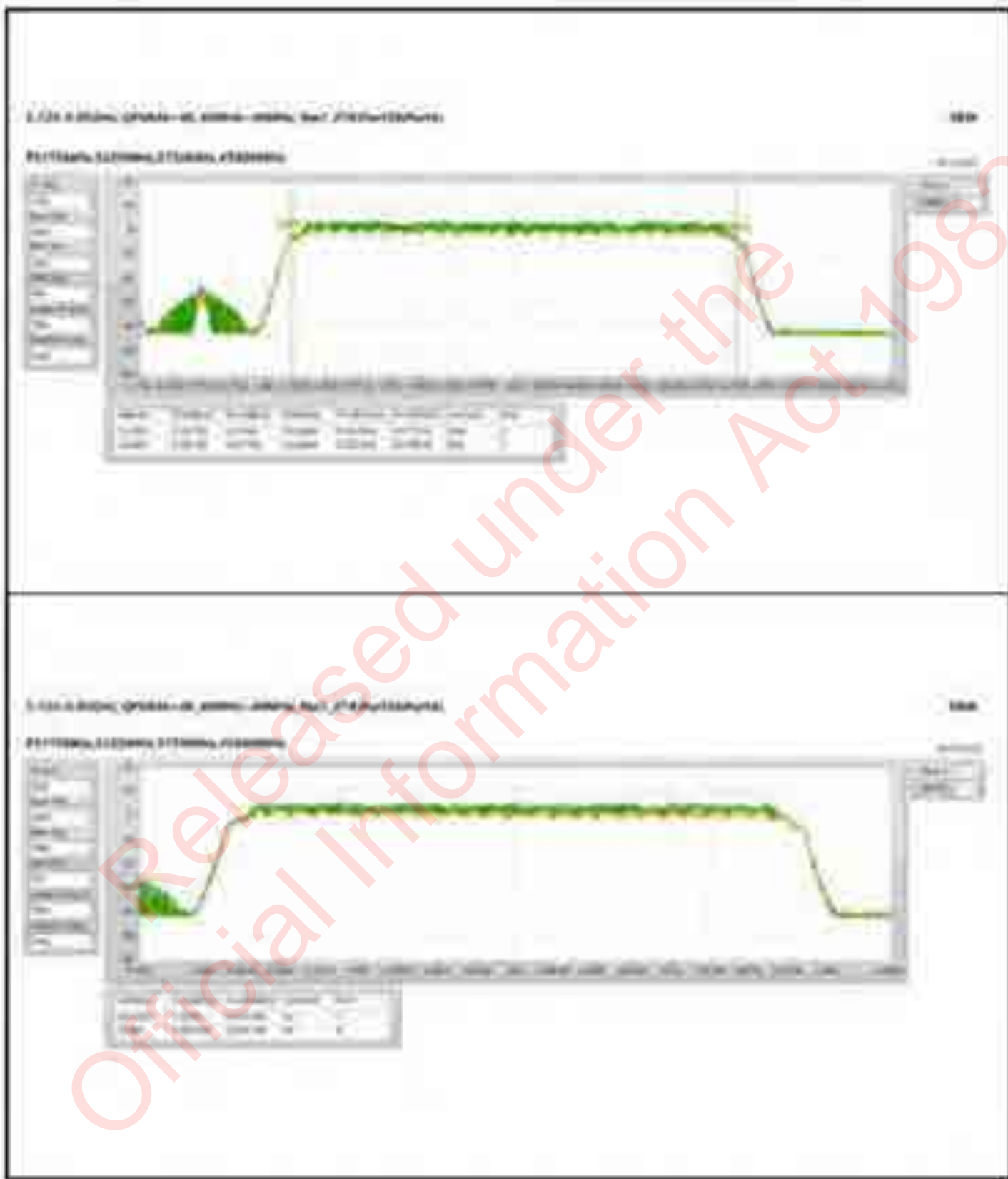



Summary

Sub	Exec Power	Total Power	ERP / Emission High for 30' ERP	ERP / Emission High for 30' ERP
	dBm	dBm	dBm	dBm
Subtotal	-	-	-	-
CP100 100W Rev1_2T8	-14.62	-14.62	10.000000	10.000000
CP100 100W Rev1_2T9	-15.10	-15.10	10.000000	10.000000
CP100 100W Rev1_2T10	-14.89	-14.89	10.000000	10.000000
CP100 100W Rev1_2T11	-14.71	-14.71	10.000000	10.000000
CP100 100W Rev1_2T12	-14.50	-14.50	10.000000	10.000000
CP100 100W Rev1_2T13	-14.87	-14.87	10.000000	10.000000
Subtotal	-	-	-	-
CP100 100W Rev1_2T14	-14.73	-14.73	10.00	10.00
CP100 100W Rev1_2T15	-14.80	-14.80	10.00	10.00
CP100 100W Rev1_2T16	-14.81	-14.81	10.00	10.00
CP100 100W Rev1_2T17	-14.81	-14.81	10.00	10.00
CP100 100W Rev1_2T18	-14.88	-14.88	10.00	10.00
CP100 100W Rev1_2T19	-14.79	-14.79	10.00	10.00

Released under the Official Information Act 2002



Result

Mod	Result	DC	Port 1	Port 2	Total Power	Power Loss	ERP / Deviation angle higher than 30° ERP	ERP vel / Deviation angle higher than 30° ERP loss
		(dBm)	(dBm)	(dBm)	(dBm)	(dBm)	(dBm)	(dBm)
CPDNL 30MHz Swt. 2T1	Pass	-	-	-	-	-	-	-
310MHz	Pass	19.8231.00	11.27	32.79	14.22	19.04	19.8214.01	19.8217.00
300MHz	Pass	19.8231.00	11.26	32.99	14.00	19.04	19.8212.03	19.8217.00
310MHz	Pass	19.8231.00	11.26	32.99	14.00	19.04	19.8217.01	19.8217.00
310MHz	Pass	19.998	11.09	32.94	13.11	19.04	19.99	19.99
310MHz	Pass	19.998	11.01	33.19	13.06	19.04	19.99	19.99
310MHz	Pass	19.998	11.02	33.30	13.02	19.04	19.99	19.99
CPDNL 30MHz Swt. 2T2	Pass	-	-	-	-	-	-	-
310MHz	Pass	19.8231.00	11.23	33.31	13.96	19.04	19.8204.01	19.8217.00
300MHz	Pass	19.8231.00	11.01	33.89	13.71	19.04	19.8217.00	19.8217.00
310MHz	Pass	19.8231.00	11.06	33.00	13.13	19.04	19.8219.08	19.8217.00
310MHz	Pass	19.998	11.06	33.06	13.08	19.04	19.99	19.99
310MHz	Pass	19.998	11.06	33.19	13.03	19.04	19.99	19.99
310MHz	Pass	19.998	11.02	33.21	13.29	19.04	19.99	19.99
CPDNL 30MHz Swt. PDE	Pass	-	-	-	-	-	-	-
310MHz	Pass	19.8231.00	11.01	33.01	13.26	19.04	19.8219.24	19.8217.00
300MHz	Pass	19.8231.00	11.04	33.03	13.00	19.04	19.8219.11	19.8217.00
310MHz	Pass	19.8231.00	11.01	33.02	13.26	19.04	19.8219.03	19.8217.00
310MHz	Pass	19.998	11.12	33.00	13.11	19.04	19.99	19.99
310MHz	Pass	19.998	11.18	33.01	13.01	19.04	19.99	19.99
310MHz	Pass	19.998	11.06	33.06	13.01	19.04	19.99	19.99
CPDNL 30MHz Swt. 2T3	Pass	-	-	-	-	-	-	-
310MHz	Pass	19.8231.00	11.00	33.11	13.31	19.04	19.8213.01	19.8217.00
300MHz	Pass	19.8231.00	11.06	33.14	13.11	19.04	19.8211.04	19.8217.00
310MHz	Pass	19.8231.00	11.01	33.00	13.01	19.04	19.8217.08	19.8217.00
310MHz	Pass	19.998	11.00	33.19	13.01	19.04	19.99	19.99
310MHz	Pass	19.998	11.02	33.08	13.01	19.04	19.99	19.99
310MHz	Pass	19.998	11.01	33.14	13.06	19.04	19.99	19.99
CPDNL 30MHz Swt. PDE	Pass	-	-	-	-	-	-	-
310MHz	Pass	19.8231.00	11.01	33.04	13.00	19.04	19.8214.04	19.8217.00
300MHz	Pass	19.8231.00	11.03	33.03	13.00	19.04	19.8219.08	19.8217.00
310MHz	Pass	19.8231.00	11.01	33.01	13.06	19.04	19.8219.00	19.8217.00
310MHz	Pass	19.998	11.01	33.01	13.08	19.04	19.99	19.99
310MHz	Pass	19.998	11.06	33.01	13.01	19.04	19.99	19.99
310MHz	Pass	19.998	11.04	33.01	13.11	19.04	19.99	19.99
CPDNL 30MHz Swt. 2T4	Pass	-	-	-	-	-	-	-
310MHz	Pass	19.8231.00	11.01	33.01	13.26	19.04	19.8217.01	19.8217.00
300MHz	Pass	19.8231.00	11.01	33.04	13.01	19.04	19.8219.03	19.8217.00
310MHz	Pass	19.8231.00	11.06	33.04	13.01	19.04	19.8217.06	19.8217.00
310MHz	Pass	19.998	11.05	33.04	13.03	19.04	19.99	19.99
310MHz	Pass	19.998	11.08	33.01	13.03	19.04	19.99	19.99
310MHz	Pass	19.998	11.01	33.01	13.01	19.04	19.99	19.99

33 (Internal Use Only) - Confidential



Summary

Mode	Total Power dBm	Total Power mW	ERP dBm	ERP mW
1-75.42000	-	-	-	-
QTYA0-05 300W-200Hz Mod. JTSF0004P402	18.00	630920	16.90/2.01	630945.02000
QTYA0-05 300W-200Hz Mod. JTSF0004P402	19.31	630908	16.90/2.00	630945.02000
QTYA0-05 300W-200Hz Mod. JTSF0004P402	19.36	630902	16.90/2.00	630945.02000
1-75.42000	-	-	-	-
QTYA0-05 300W-200Hz Mod. JTSF0004P402	19.31	630908	16.90	630945
QTYA0-05 300W-200Hz Mod. JTSF0004P402	19.36	630902	16.90	630945
QTYA0-05 300W-200Hz Mod. JTSF0004P402	19.36	630902	16.90	630945

Released under the Official Information Act 1982



Result

Mod.	Result	DO dBm	Port 1 dBm	Port 2 dBm	Port 3 dBm	Port 4 dBm	Total Power dBm	Power Limit dBm	ERP dBm	ERP Limit dBm
QPSK-Q, 20MHz-20MHz, Mod_2TSPwr1Pwr2	Pass	14.802184	11.22	12.82	---	---	14.82	30.04	20.951227	14.0138
PSK-Q, 20MHz-20MHz, Mod_2TSPwr1Pwr2	Pass	14.802184	11.22	12.82	---	---	14.82	30.04	20.951227	14.0138
PSK-Q, 20MHz-20MHz, Mod_2TSPwr1Pwr2	Pass	14.802184	11.22	12.82	---	---	14.82	30.04	20.951227	14.0138
PSK-Q, 20MHz-20MHz, Mod_2TSPwr1Pwr2	Pass	14.802184	11.22	12.82	---	---	14.82	30.04	20.951227	14.0138
PSK-Q, 20MHz-20MHz, Mod_2TSPwr1Pwr2	Pass	14.802184	11.22	12.82	---	---	14.82	30.04	20.951227	14.0138
PSK-Q, 20MHz-20MHz, Mod_2TSPwr1Pwr2	Pass	14.802184	11.22	12.82	---	---	14.82	30.04	20.951227	14.0138
PSK-Q, 20MHz-20MHz, Mod_2TSPwr1Pwr2	Pass	14.802184	11.22	12.82	---	---	14.82	30.04	20.951227	14.0138
PSK-Q, 20MHz-20MHz, Mod_2TSPwr1Pwr2	Pass	14.802184	11.22	12.82	---	---	14.82	30.04	20.951227	14.0138
PSK-Q, 20MHz-20MHz, Mod_2TSPwr1Pwr2	Pass	14.802184	11.22	12.82	---	---	14.82	30.04	20.951227	14.0138
PSK-Q, 20MHz-20MHz, Mod_2TSPwr1Pwr2	Pass	14.802184	11.22	12.82	---	---	14.82	30.04	20.951227	14.0138

SE - International P.A. Test Equipment

Released under the Official Information Act 1982



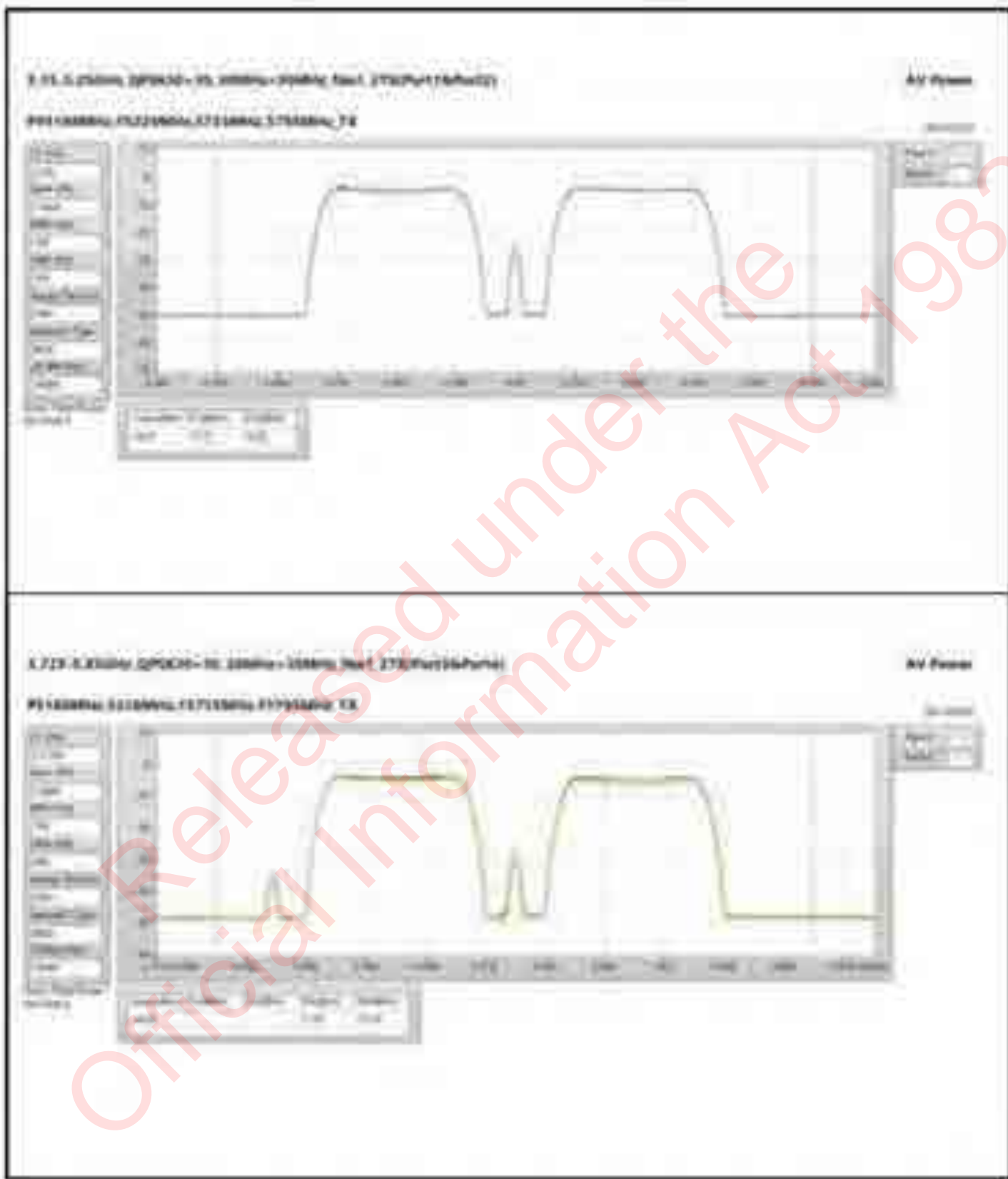

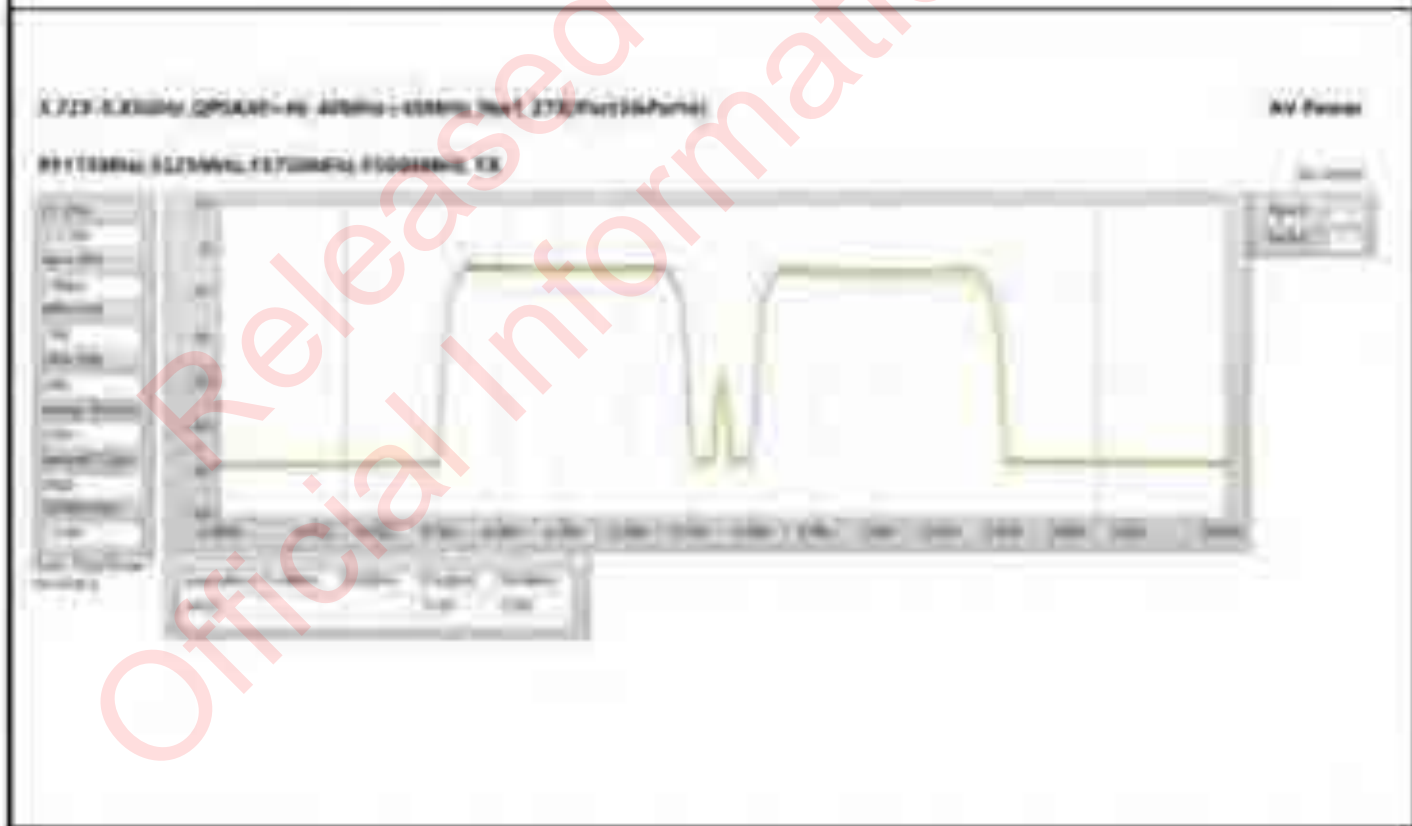
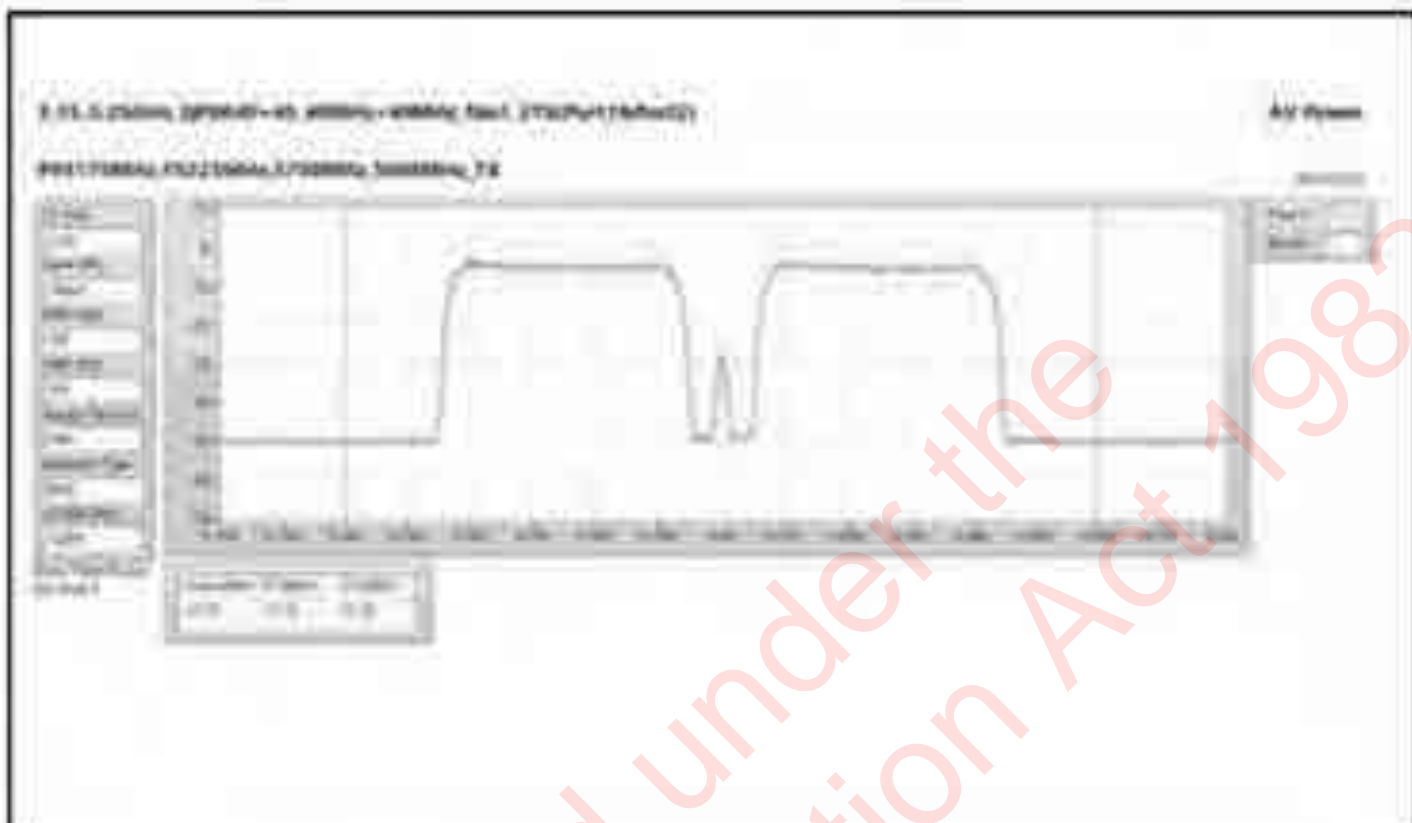



Summary

Mod	PO value/area
U7512000	—
OP03 0800 NoC 278	0.00
OP04 0800 NoC 278	0.00
OP05 0800 NoC 278	0.00
OP06 0800 NoC 278	0.00
OP07 0800 NoC 278	0.00
OP08 0800 NoC 278	0.00
OP09 0800 NoC 278	0.00
OP10 0800 NoC 278	0.00
OP11 0800 NoC 278	0.00
OP12 0800 NoC 278	0.00
OP13 0800 NoC 278	0.00
OP14 0800 NoC 278	0.00
OP15 0800 NoC 278	0.00
OP16 0800 NoC 278	0.00
OP17 0800 NoC 278	0.00
OP18 0800 NoC 278	0.00
OP19 0800 NoC 278	0.00
OP20 0800 NoC 278	0.00
OP21 0800 NoC 278	0.00
OP22 0800 NoC 278	0.00
OP23 0800 NoC 278	0.00
OP24 0800 NoC 278	0.00
OP25 0800 NoC 278	0.00
OP26 0800 NoC 278	0.00
OP27 0800 NoC 278	0.00
OP28 0800 NoC 278	0.00
OP29 0800 NoC 278	0.00
OP30 0800 NoC 278	0.00
OP31 0800 NoC 278	0.00
OP32 0800 NoC 278	0.00
OP33 0800 NoC 278	0.00
OP34 0800 NoC 278	0.00
OP35 0800 NoC 278	0.00
OP36 0800 NoC 278	0.00
OP37 0800 NoC 278	0.00
OP38 0800 NoC 278	0.00
OP39 0800 NoC 278	0.00
OP40 0800 NoC 278	0.00
OP41 0800 NoC 278	0.00
OP42 0800 NoC 278	0.00
OP43 0800 NoC 278	0.00
OP44 0800 NoC 278	0.00
OP45 0800 NoC 278	0.00
OP46 0800 NoC 278	0.00
OP47 0800 NoC 278	0.00
OP48 0800 NoC 278	0.00
OP49 0800 NoC 278	0.00
OP50 0800 NoC 278	0.00
OP51 0800 NoC 278	0.00
OP52 0800 NoC 278	0.00
OP53 0800 NoC 278	0.00
OP54 0800 NoC 278	0.00
OP55 0800 NoC 278	0.00
OP56 0800 NoC 278	0.00
OP57 0800 NoC 278	0.00
OP58 0800 NoC 278	0.00
OP59 0800 NoC 278	0.00
OP60 0800 NoC 278	0.00
OP61 0800 NoC 278	0.00
OP62 0800 NoC 278	0.00
OP63 0800 NoC 278	0.00
OP64 0800 NoC 278	0.00
OP65 0800 NoC 278	0.00
OP66 0800 NoC 278	0.00
OP67 0800 NoC 278	0.00
OP68 0800 NoC 278	0.00
OP69 0800 NoC 278	0.00
OP70 0800 NoC 278	0.00
OP71 0800 NoC 278	0.00
OP72 0800 NoC 278	0.00
OP73 0800 NoC 278	0.00
OP74 0800 NoC 278	0.00
OP75 0800 NoC 278	0.00
OP76 0800 NoC 278	0.00
OP77 0800 NoC 278	0.00
OP78 0800 NoC 278	0.00
OP79 0800 NoC 278	0.00
OP80 0800 NoC 278	0.00
OP81 0800 NoC 278	0.00
OP82 0800 NoC 278	0.00
OP83 0800 NoC 278	0.00
OP84 0800 NoC 278	0.00
OP85 0800 NoC 278	0.00
OP86 0800 NoC 278	0.00
OP87 0800 NoC 278	0.00
OP88 0800 NoC 278	0.00
OP89 0800 NoC 278	0.00
OP90 0800 NoC 278	0.00
OP91 0800 NoC 278	0.00
OP92 0800 NoC 278	0.00
OP93 0800 NoC 278	0.00
OP94 0800 NoC 278	0.00
OP95 0800 NoC 278	0.00
OP96 0800 NoC 278	0.00
OP97 0800 NoC 278	0.00
OP98 0800 NoC 278	0.00
OP99 0800 NoC 278	0.00
OP100 0800 NoC 278	0.00

0800 0800 NoC 278

Released under the Official Information Act 1982



Result

Sub	Unit	OC (%)	Part 1 (%)	Part 2 (%)	FD (%)	10 Line (%)
OPTICAL 2000s Rev2 JTE						
11000s	Pass	11.90	4.20	3.30	3.21	1.98
12000s	Pass	11.90	4.30	3.30	3.80	1.98
13000s	Pass	11.90	4.20	3.20	3.81	1.98
14000s	Pass	11.90	7.80	3.50	10.00	20.00
15000s	Pass	11.90	8.70	3.20	10.00	20.00
16000s	Pass	11.90	8.20	3.20	10.00	20.00
OPTICAL 1000s Rev2 JTE						
11000s	Pass	11.90	-1.50	-0.30	4.30	1.98
12000s	Pass	11.90	4.30	3.30	3.80	1.98
13000s	Pass	11.90	4.40	3.40	4.80	1.98
14000s	Pass	11.90	5.10	4.00	4.81	20.00
15000s	Pass	11.90	3.20	4.00	8.00	20.00
16000s	Pass	11.90	3.20	4.20	3.20	20.00
OPTICAL 5000s Rev2 JTE						
11000s	Pass	11.90	-11.00	-0.30	4.30	1.98
12000s	Pass	11.90	3.30	3.20	4.30	1.98
13000s	Pass	11.90	4.30	3.40	4.80	1.98
14000s	Pass	11.90	7.80	3.20	4.80	20.00
15000s	Pass	11.90	3.30	3.30	8.00	20.00
16000s	Pass	11.90	3.80	3.20	4.20	20.00
OPTICAL 3000s Rev2 JTE						
11000s	Pass	11.90	-14.00	-0.30	-0.30	1.98
12000s	Pass	11.90	3.80	3.30	4.80	1.98
13000s	Pass	11.90	4.30	3.30	4.80	1.98
14000s	Pass	11.90	3.80	3.30	4.80	20.00
15000s	Pass	11.90	3.30	3.30	4.80	20.00
16000s	Pass	11.90	3.30	3.40	4.80	20.00
OPTICAL 4000s Rev2 JTE						
11000s	Pass	11.90	-14.00	-1.50	-1.50	1.98
12000s	Pass	11.90	3.80	3.30	4.80	1.98
13000s	Pass	11.90	3.80	3.40	4.80	1.98
14000s	Pass	11.90	8.50	4.00	3.80	20.00
15000s	Pass	11.90	3.30	3.30	4.80	20.00
16000s	Pass	11.90	3.80	3.30	3.80	20.00

JTE - Optical Lens 1000s - 10000s (S/N 10000000 - 10000000) April 2010 to 09th June 2010
 JTE - Optical Lens 2000s - 10000s (S/N 10000000 - 10000000) April 2010 to 09th June 2010

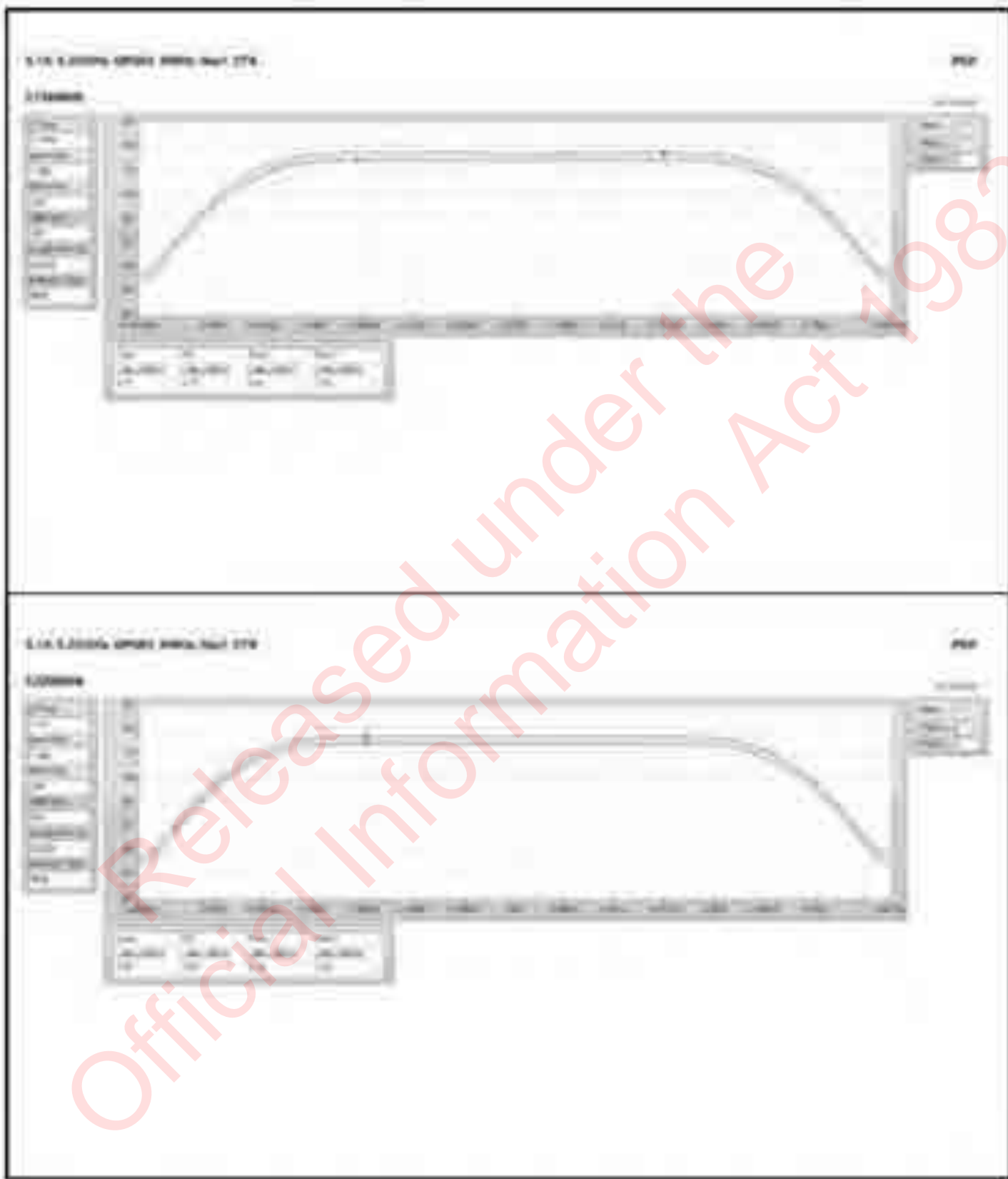

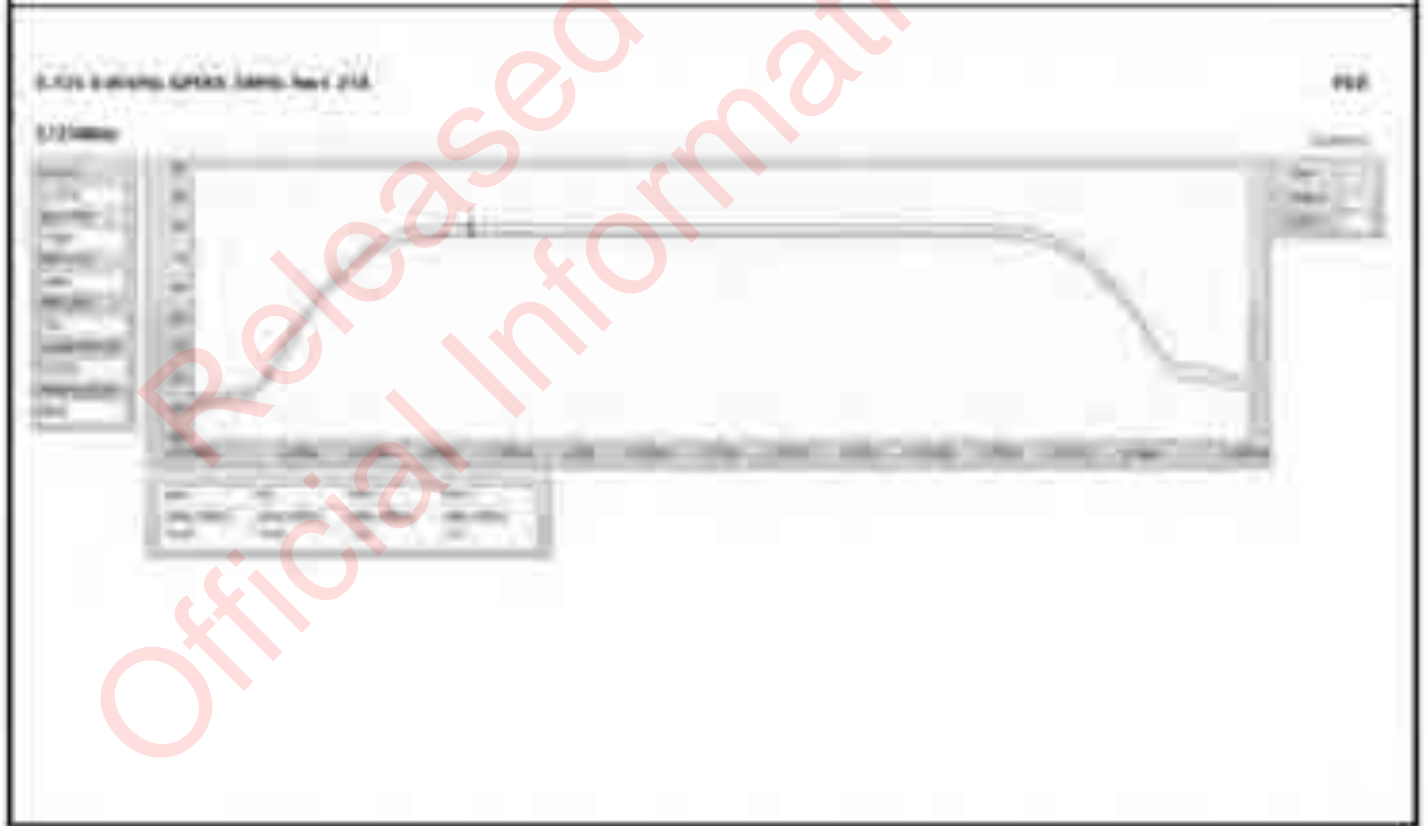
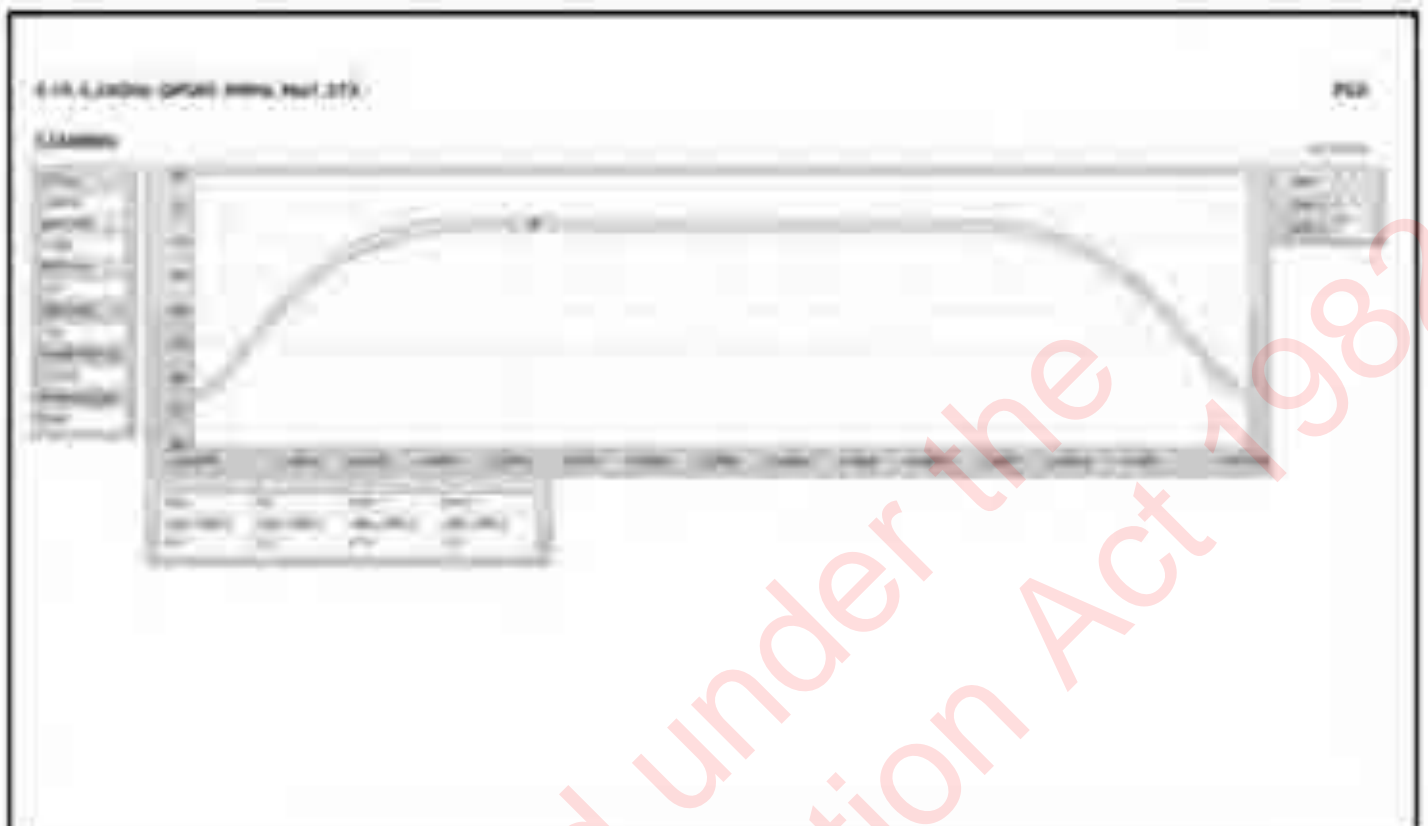

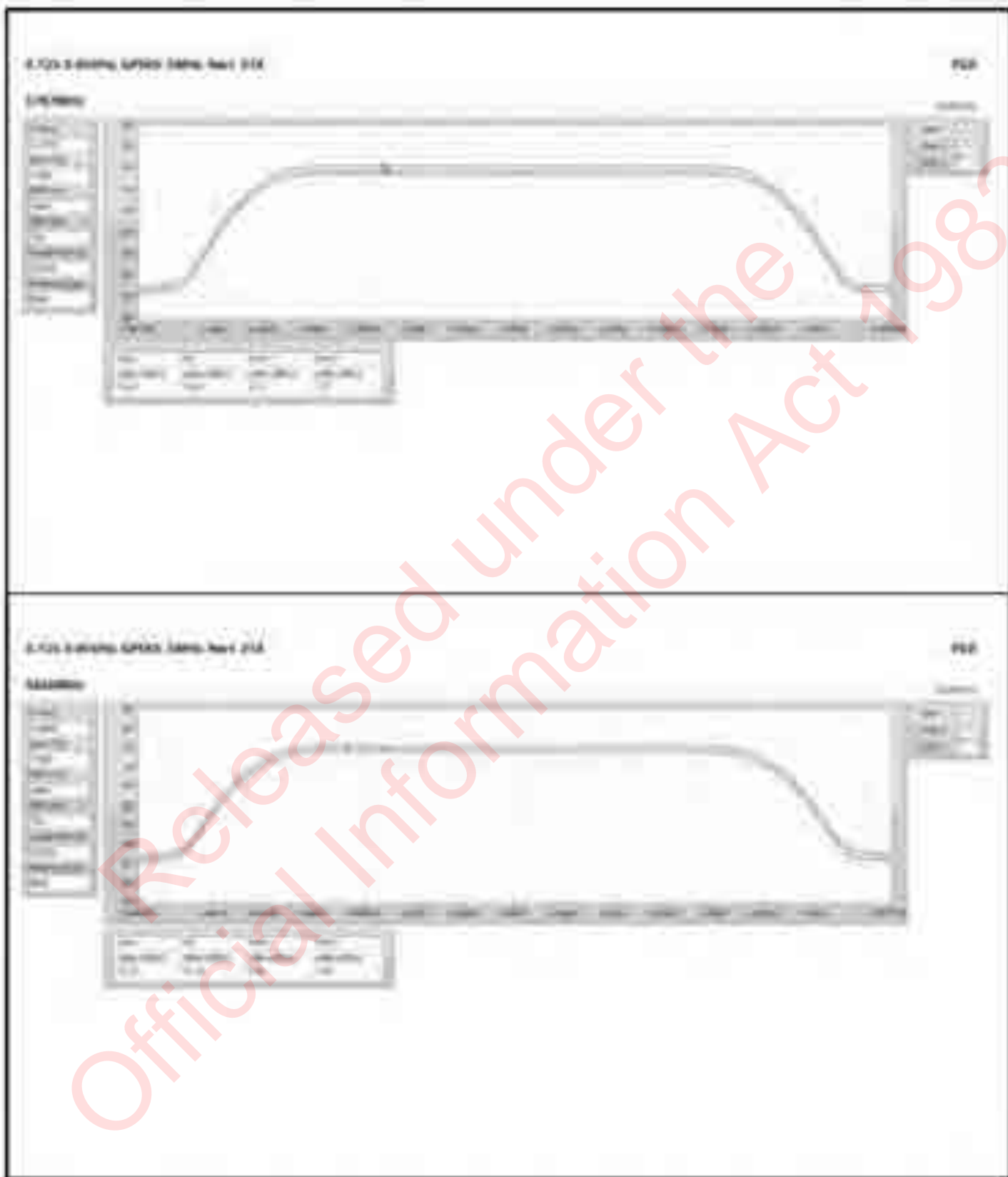

Released under the
Official Information Act 1982

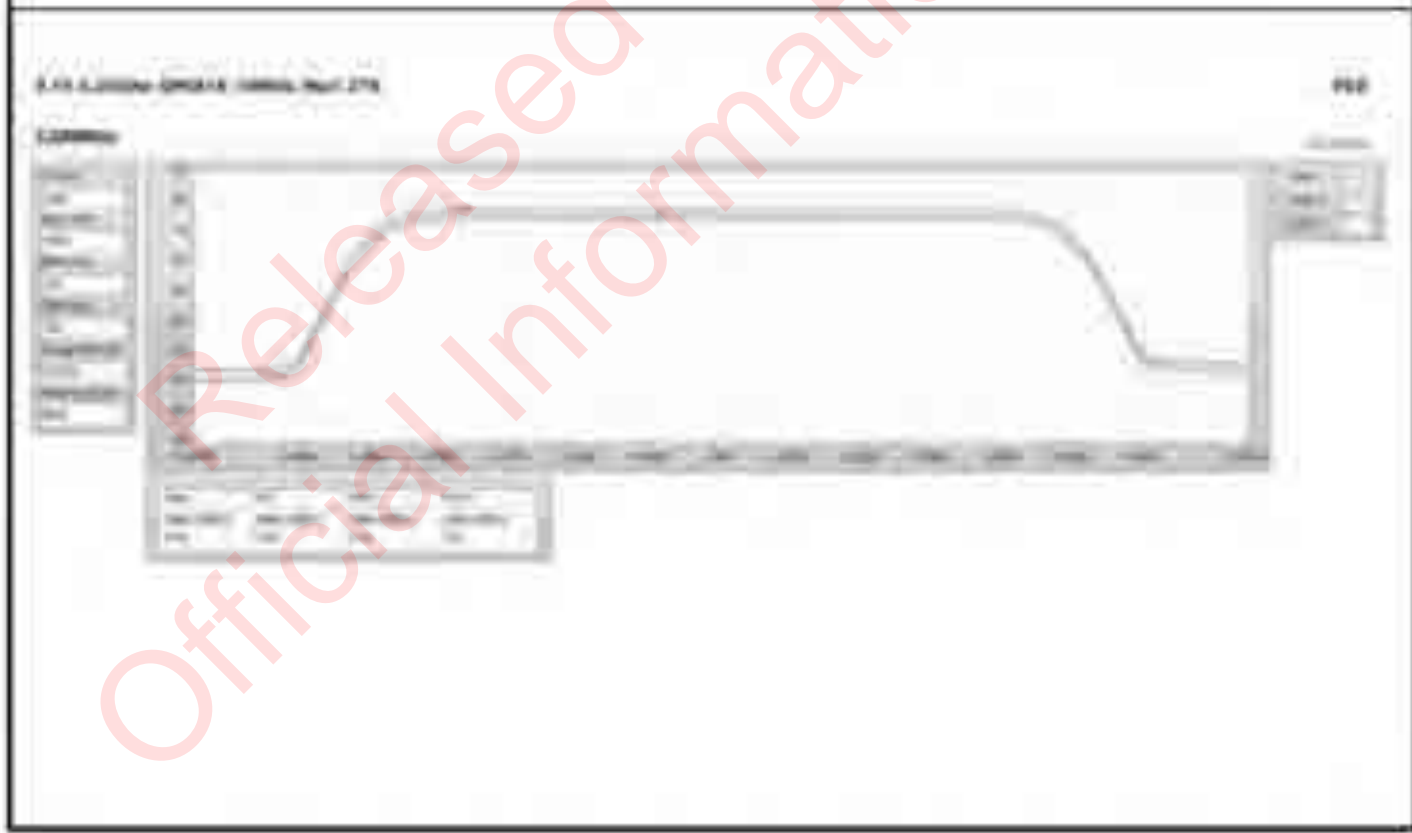
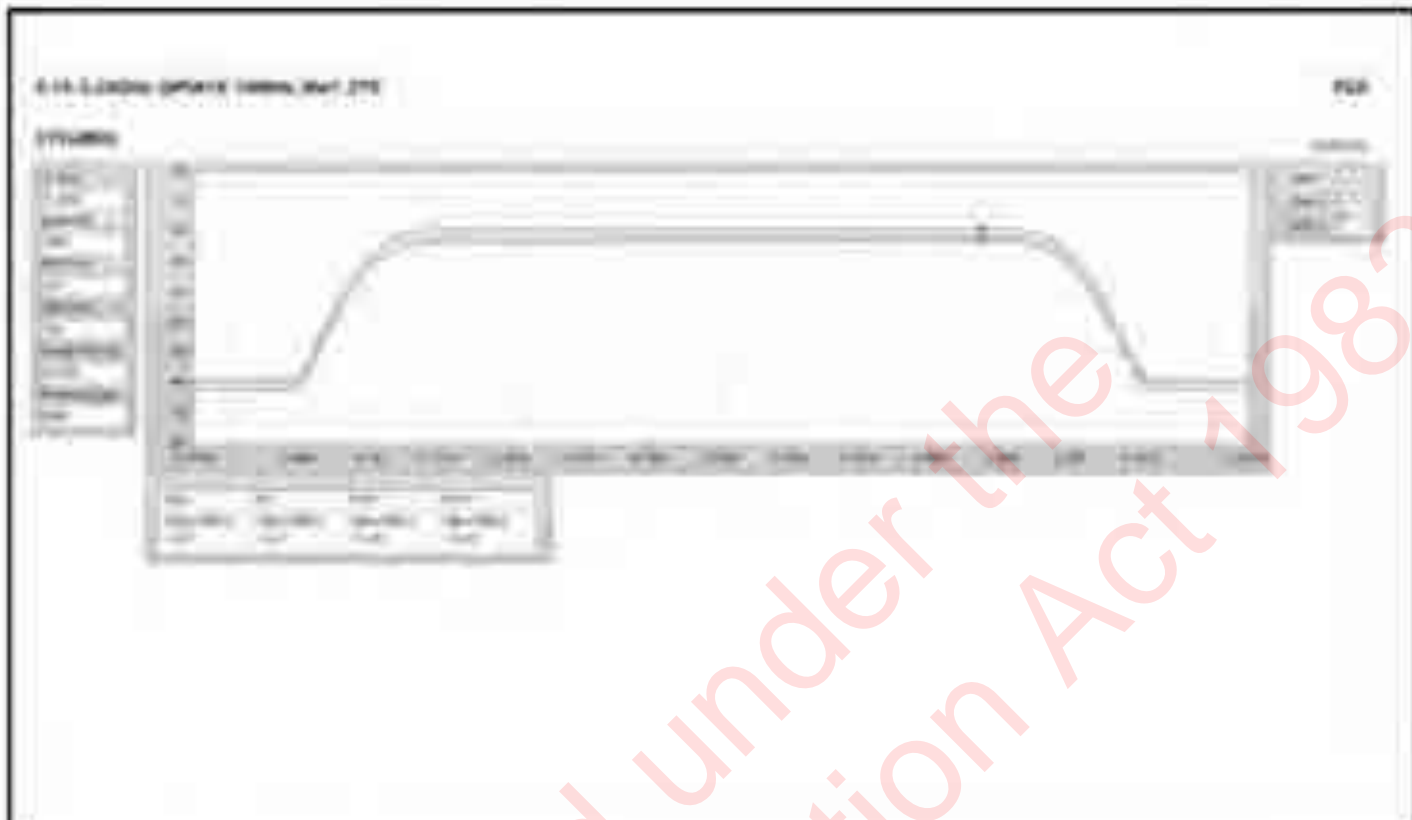

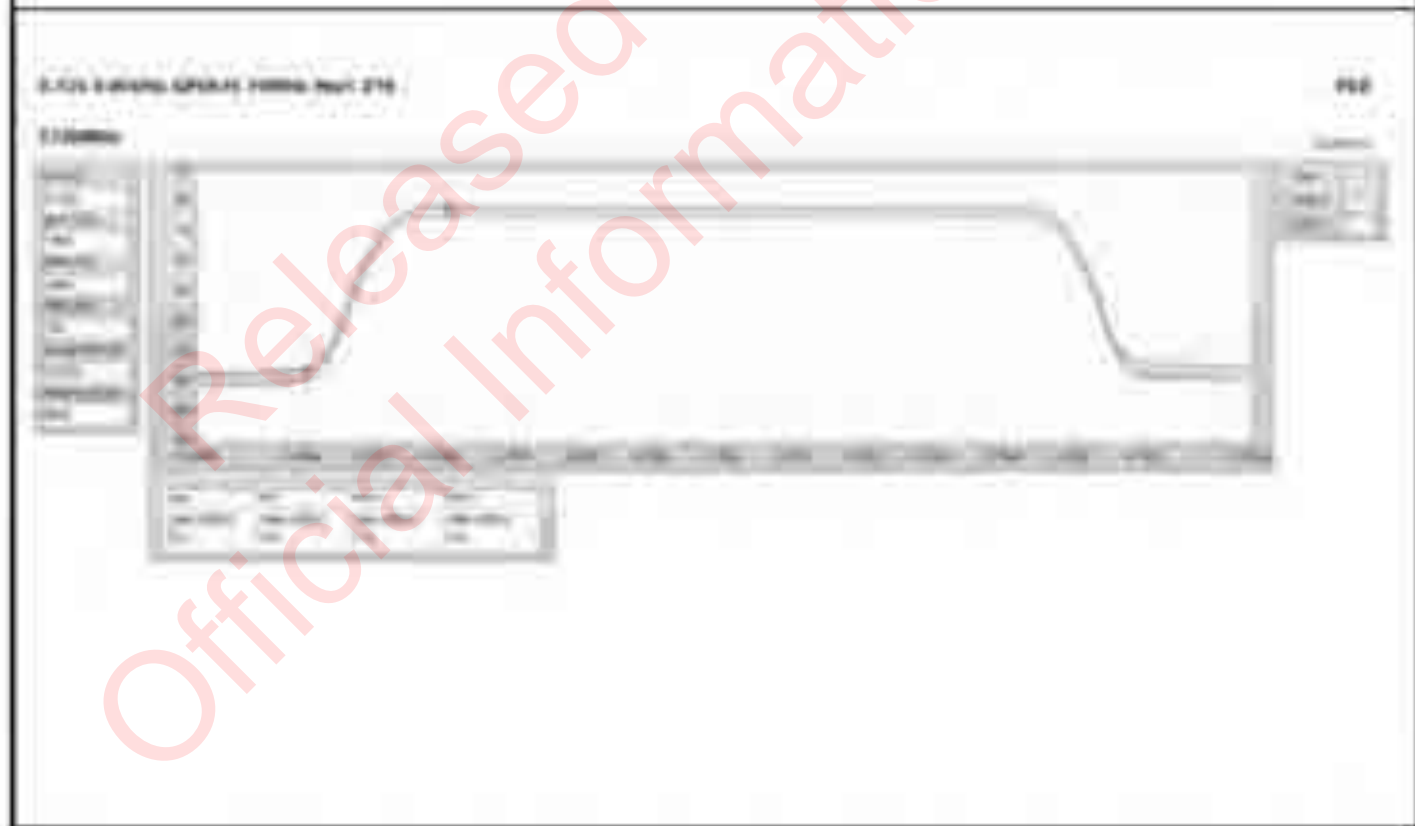
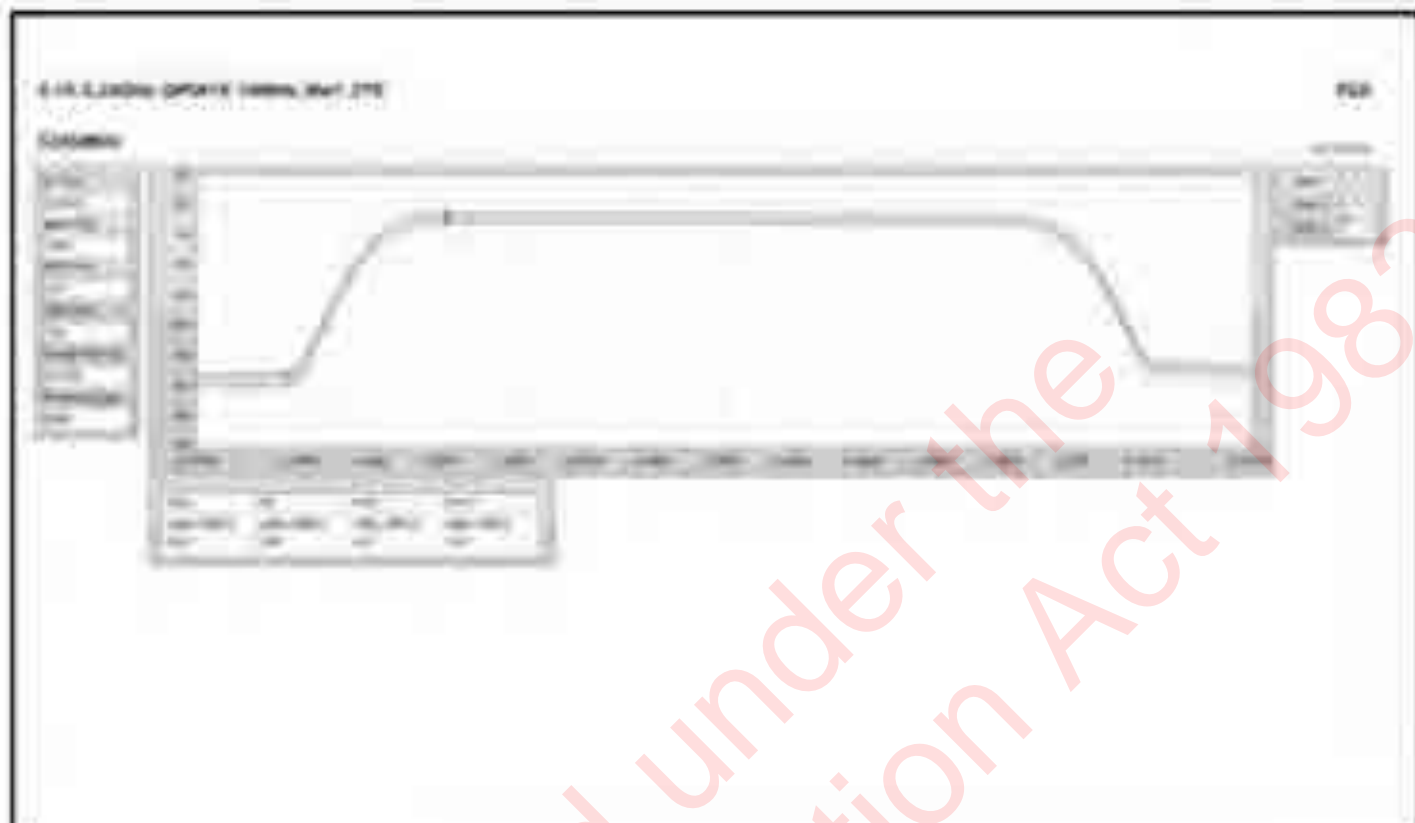

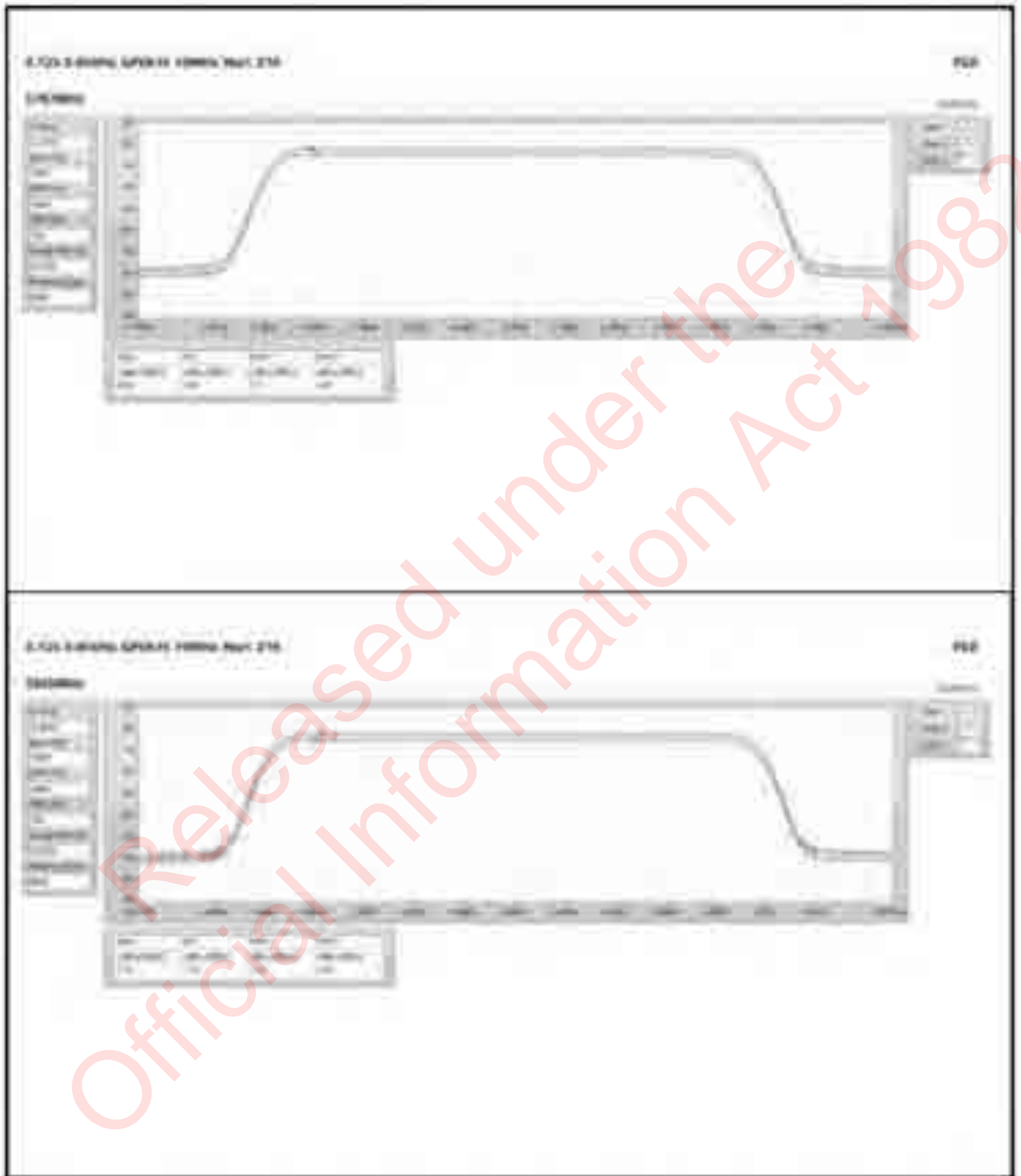

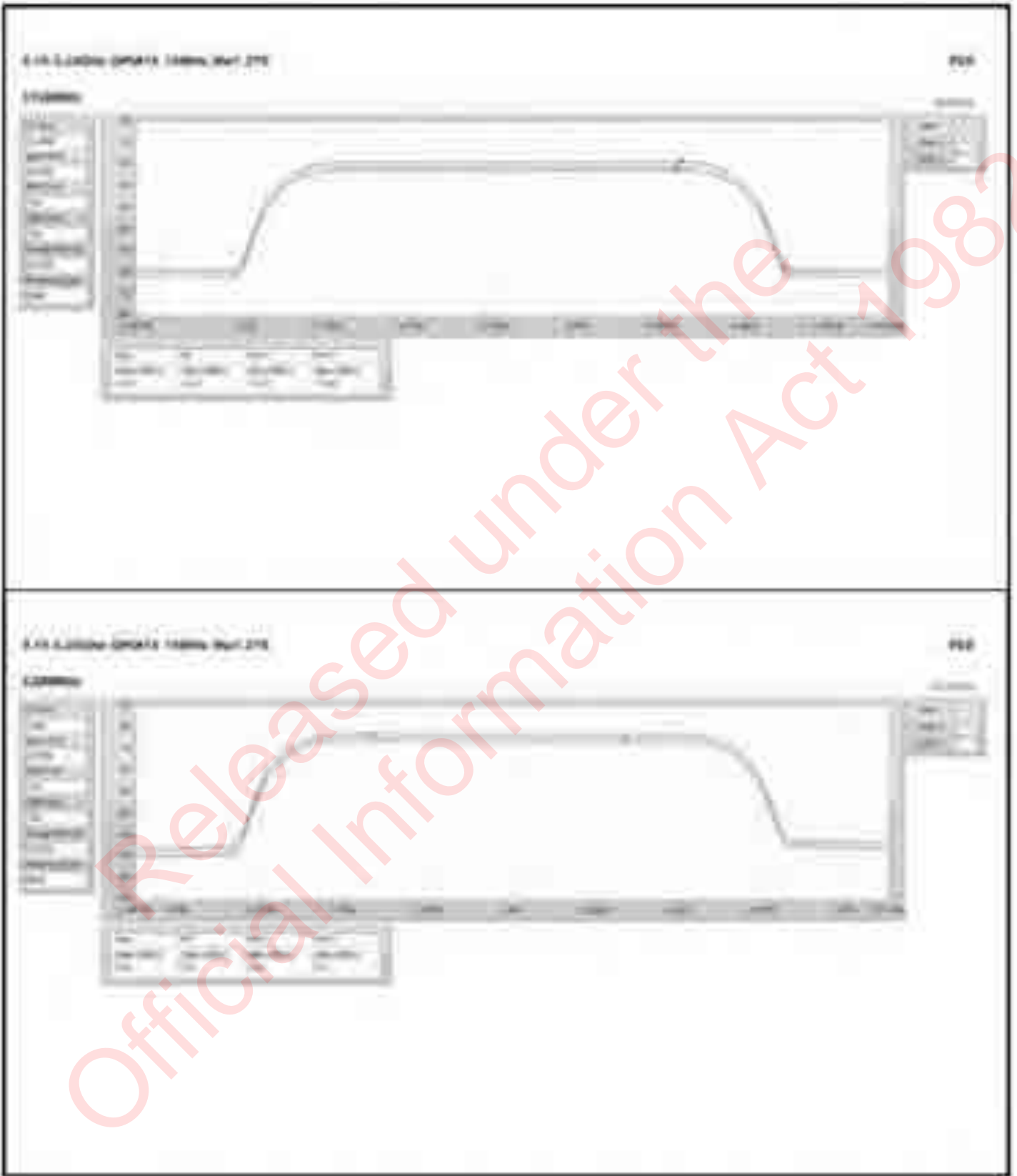

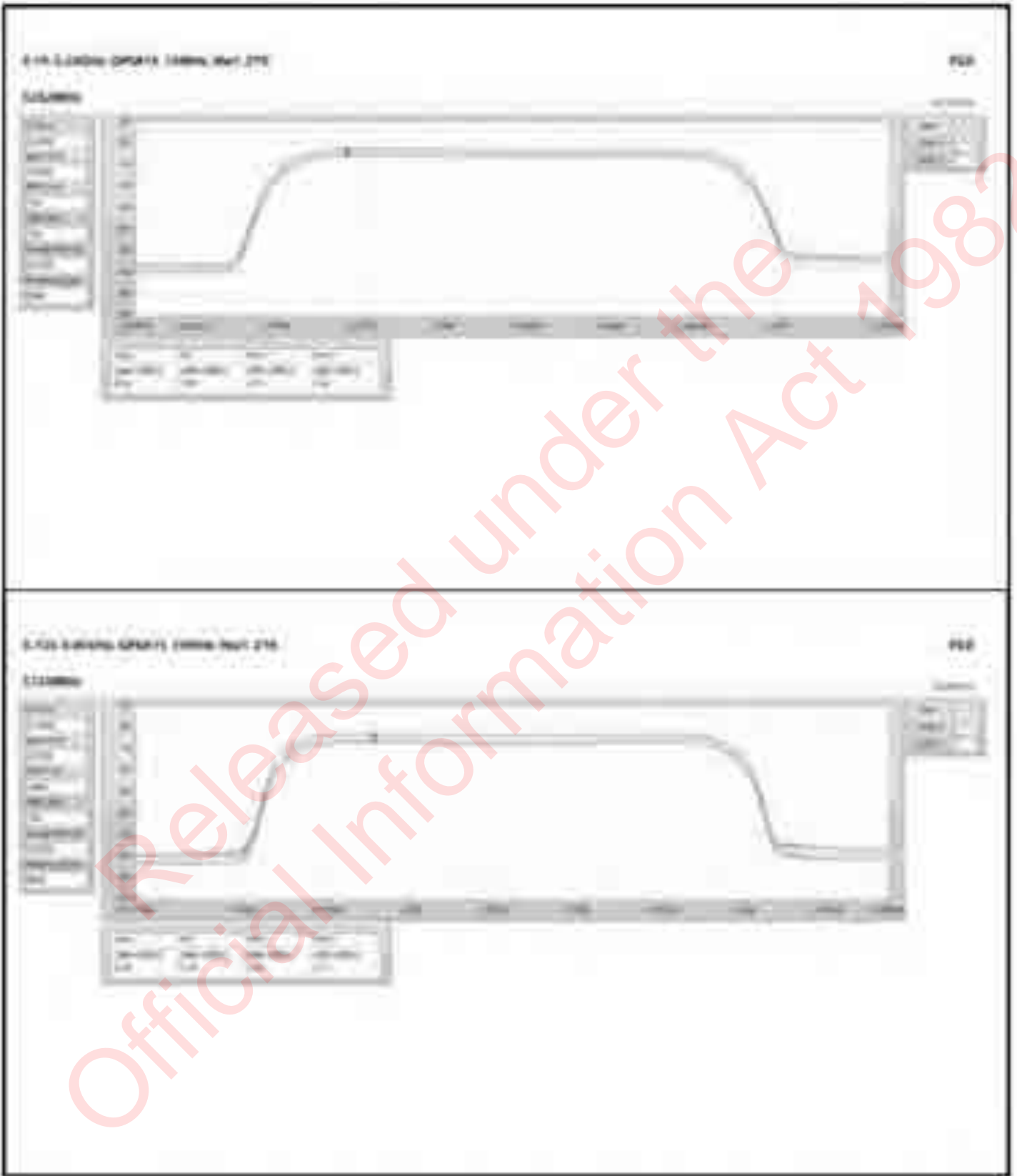

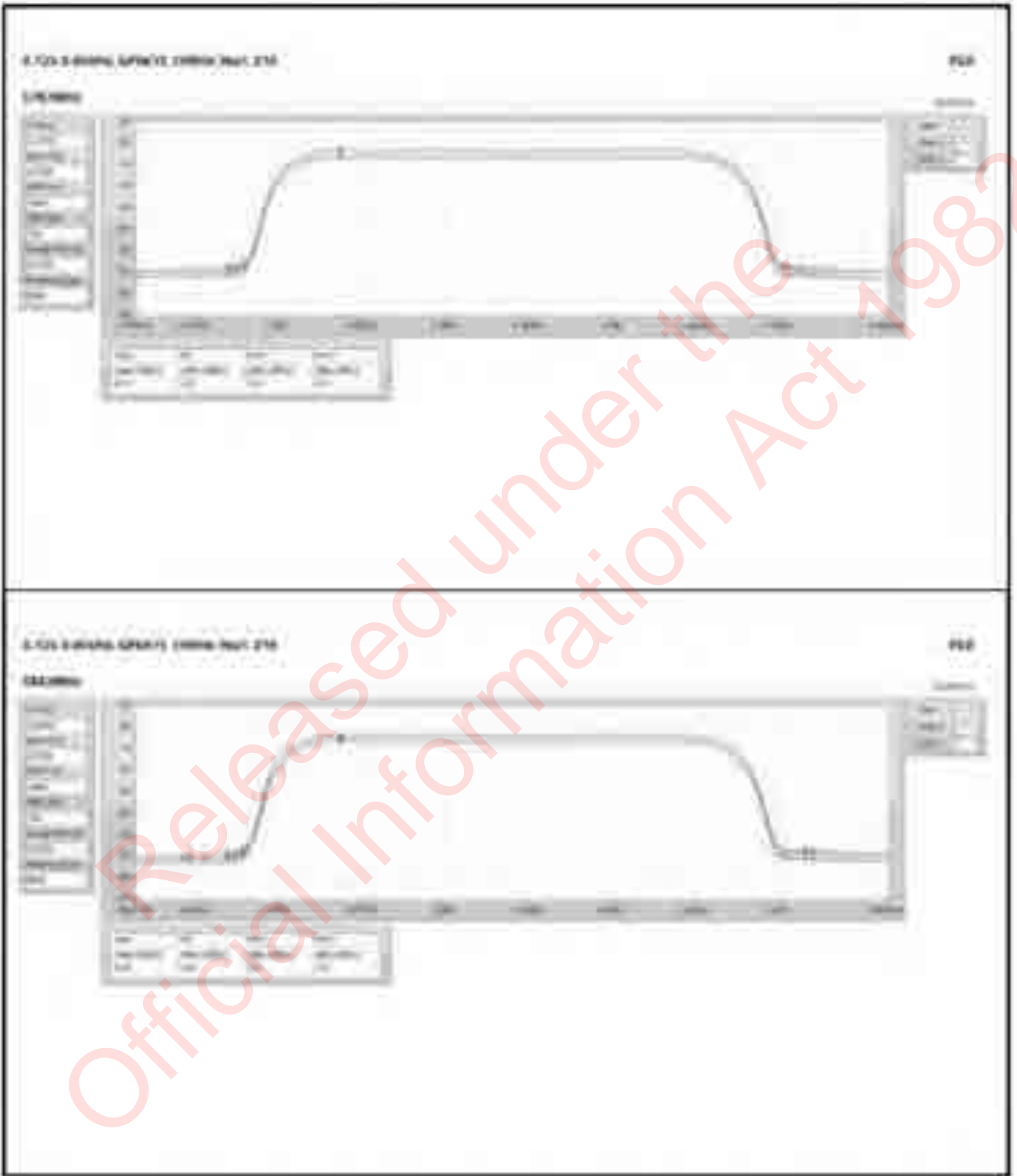

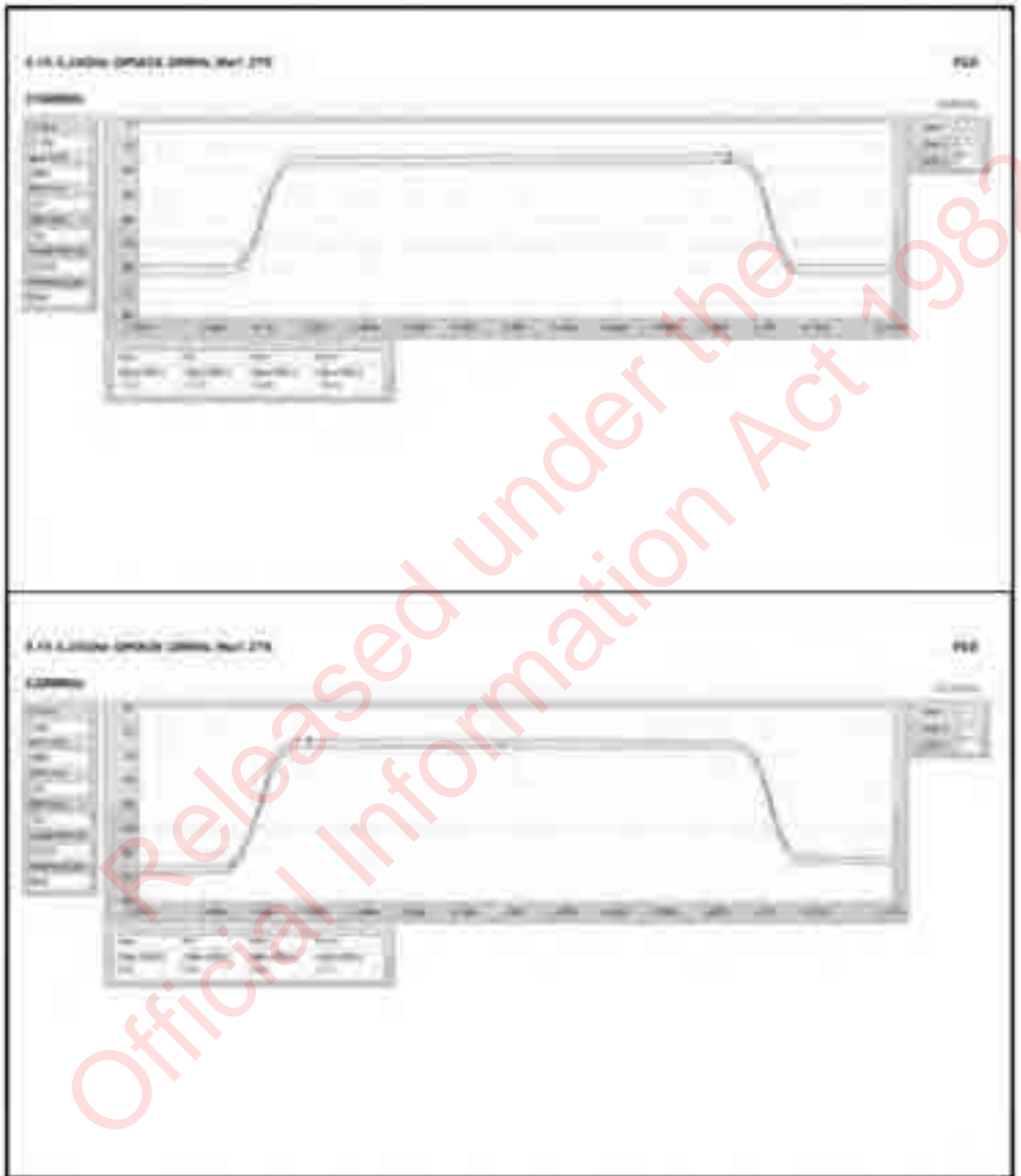

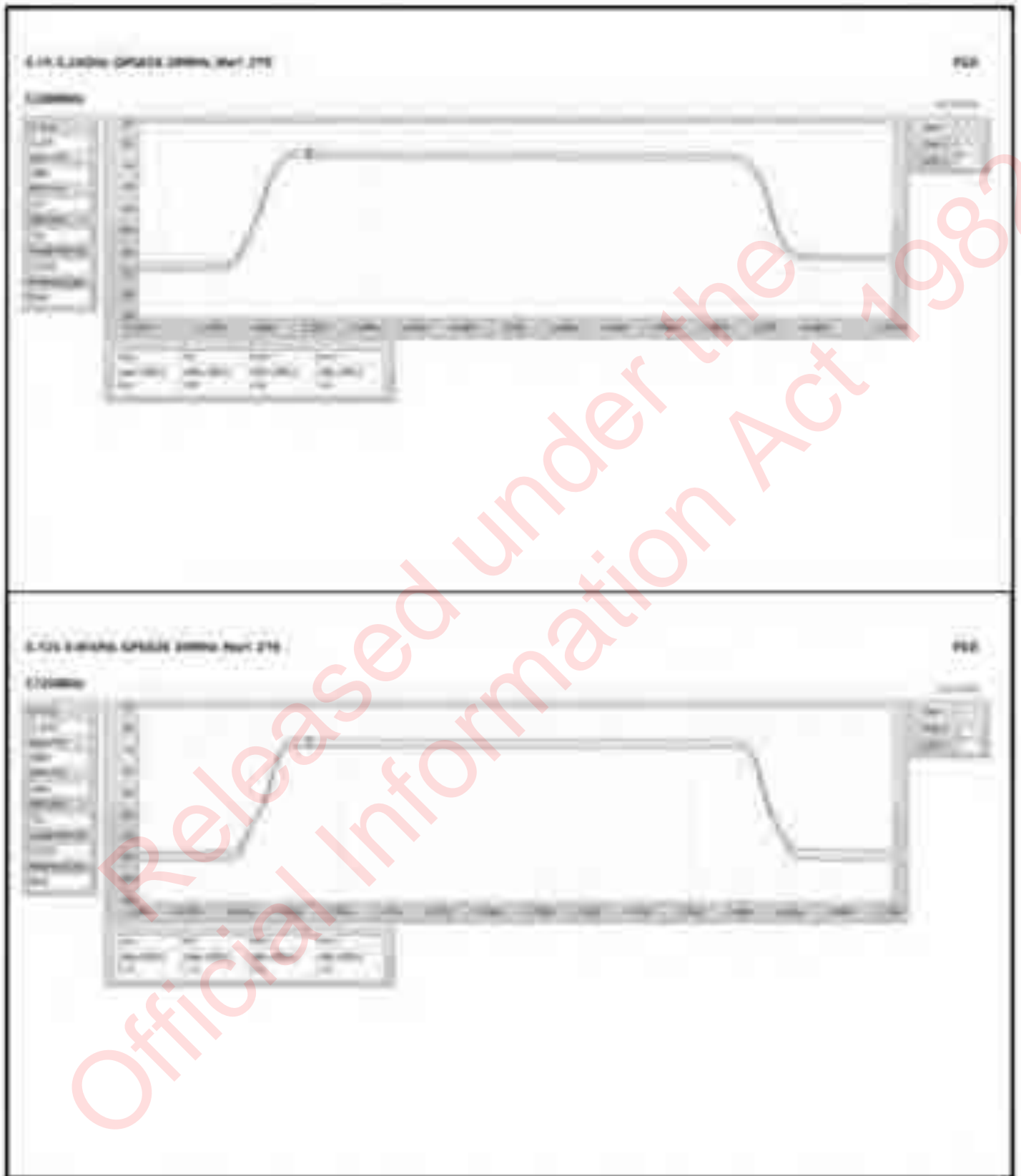

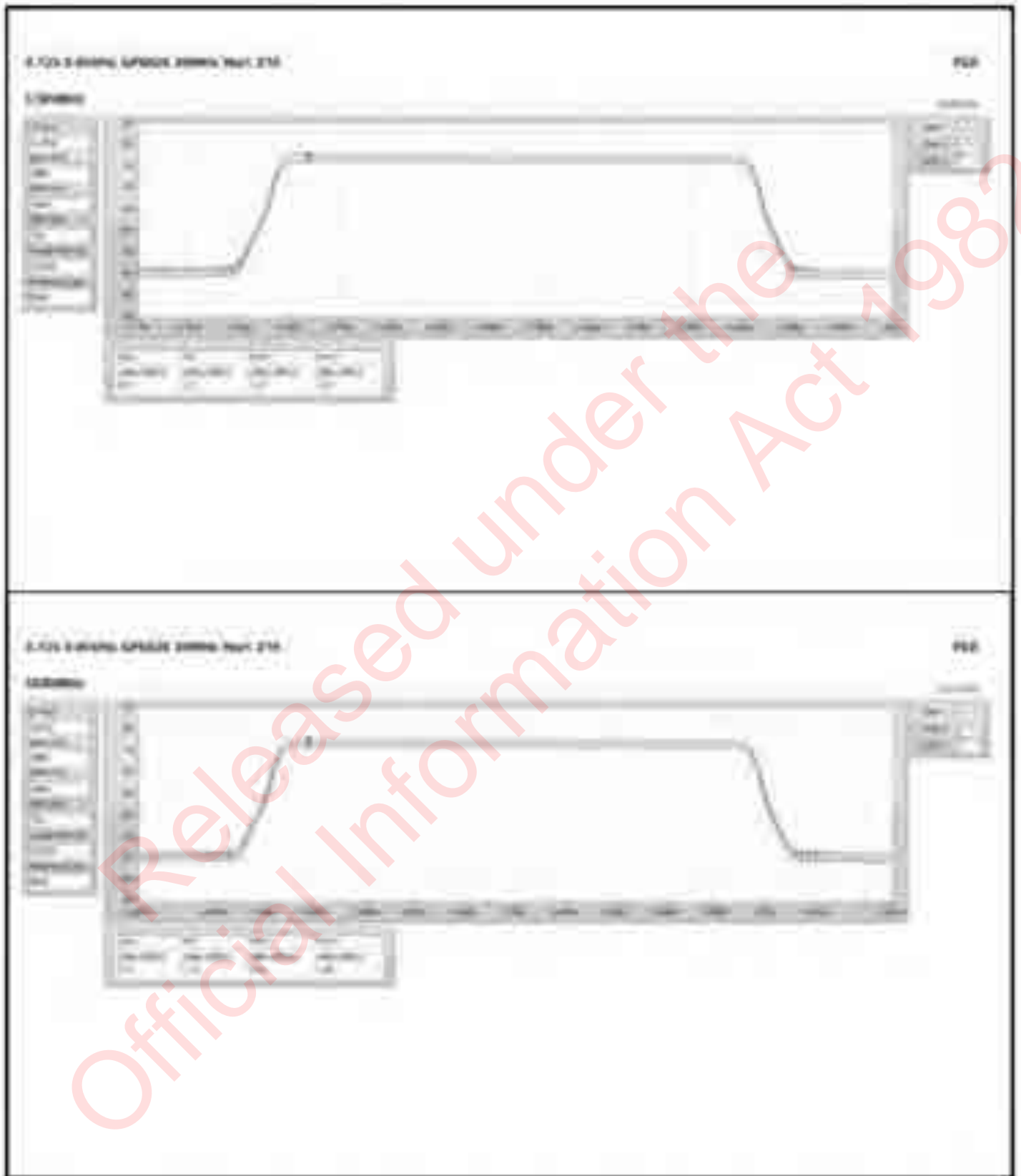

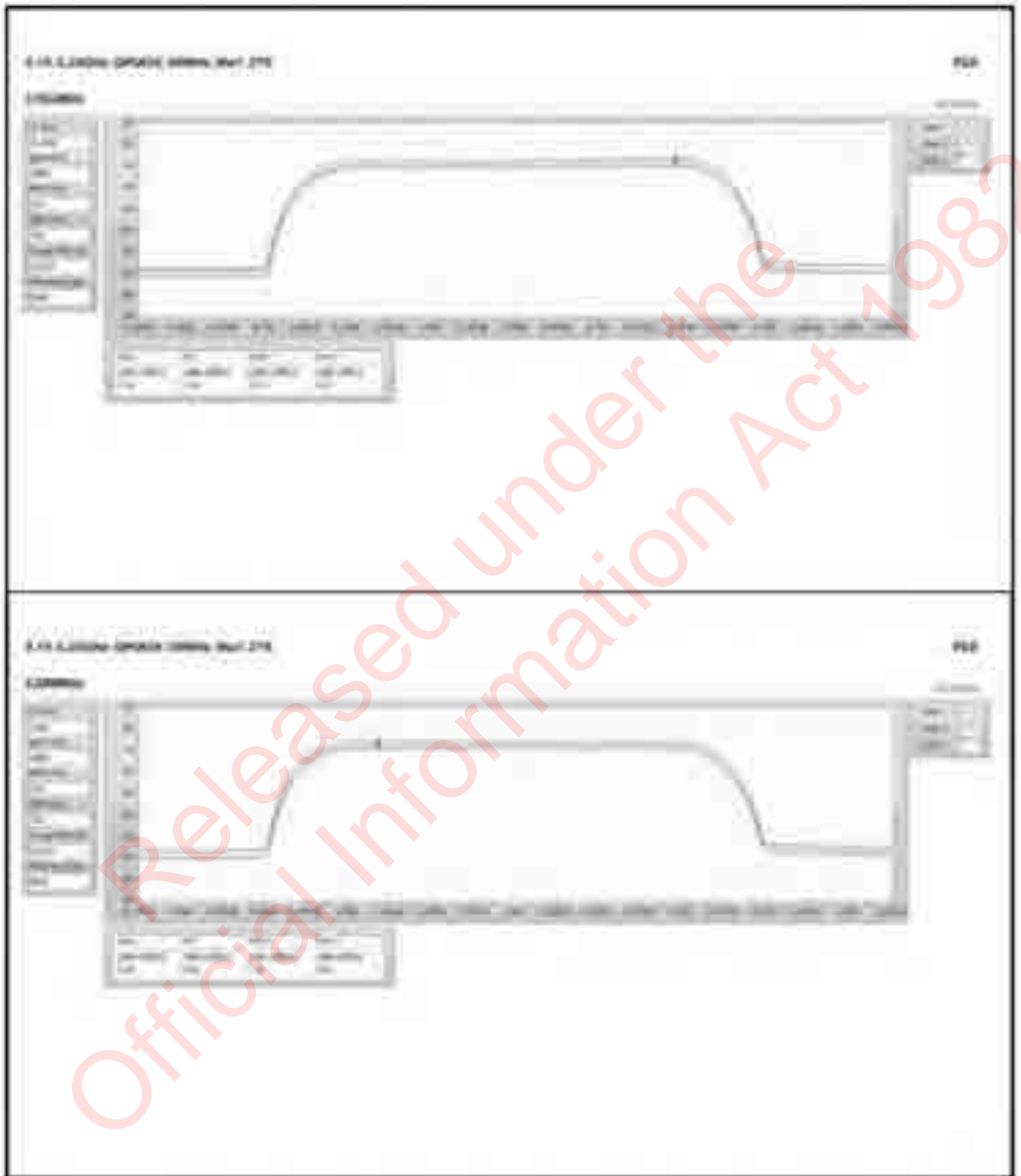

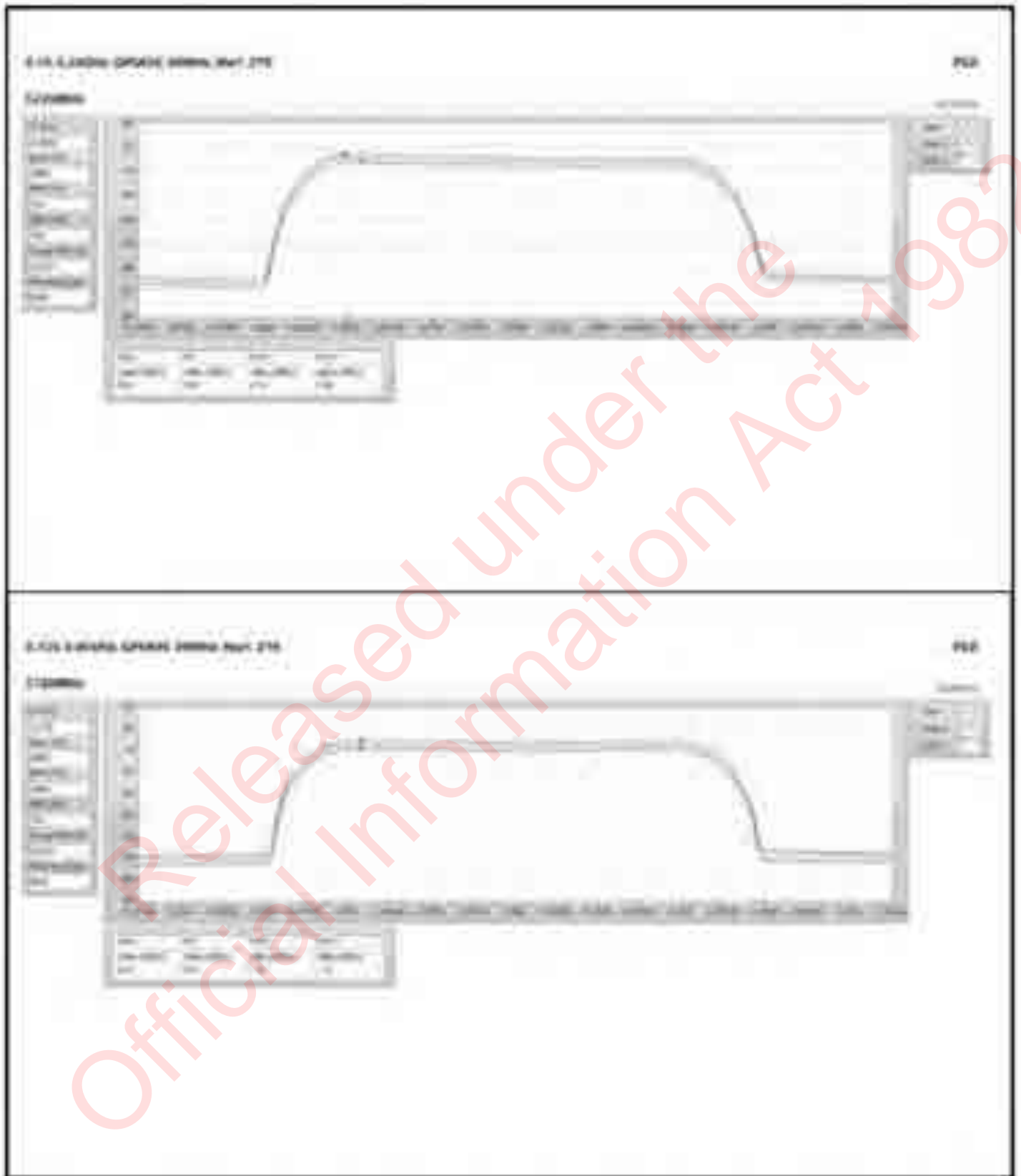

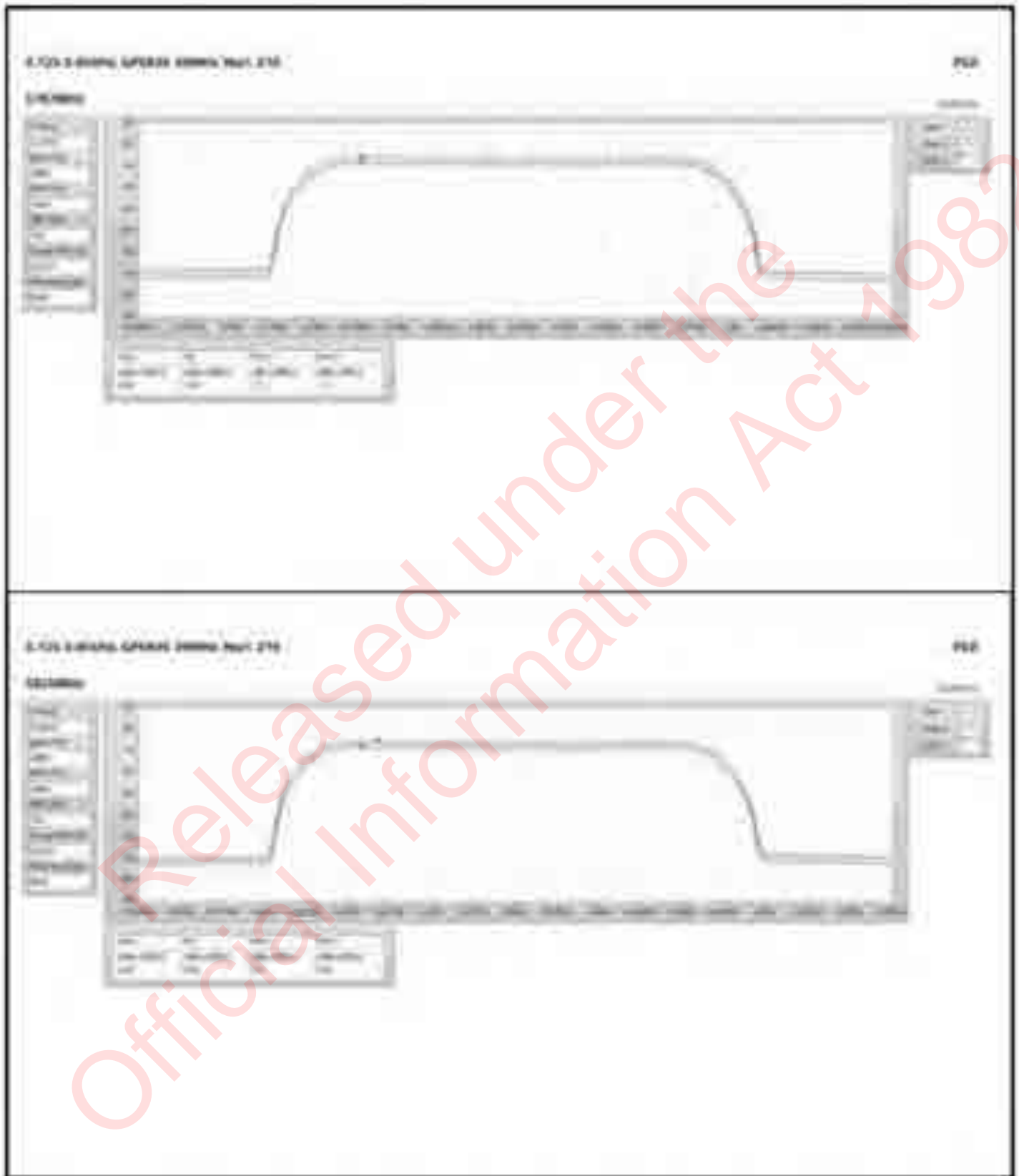

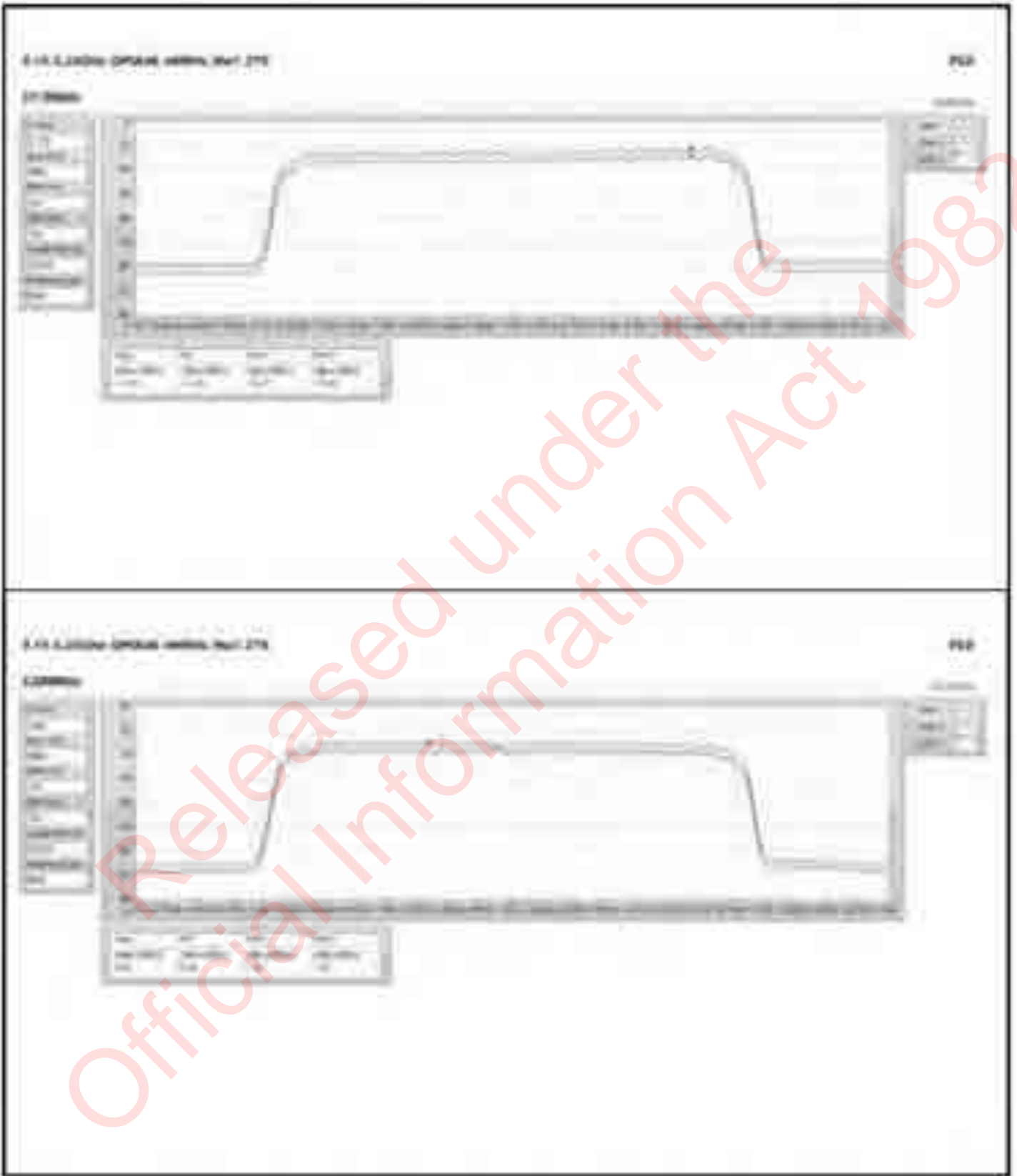

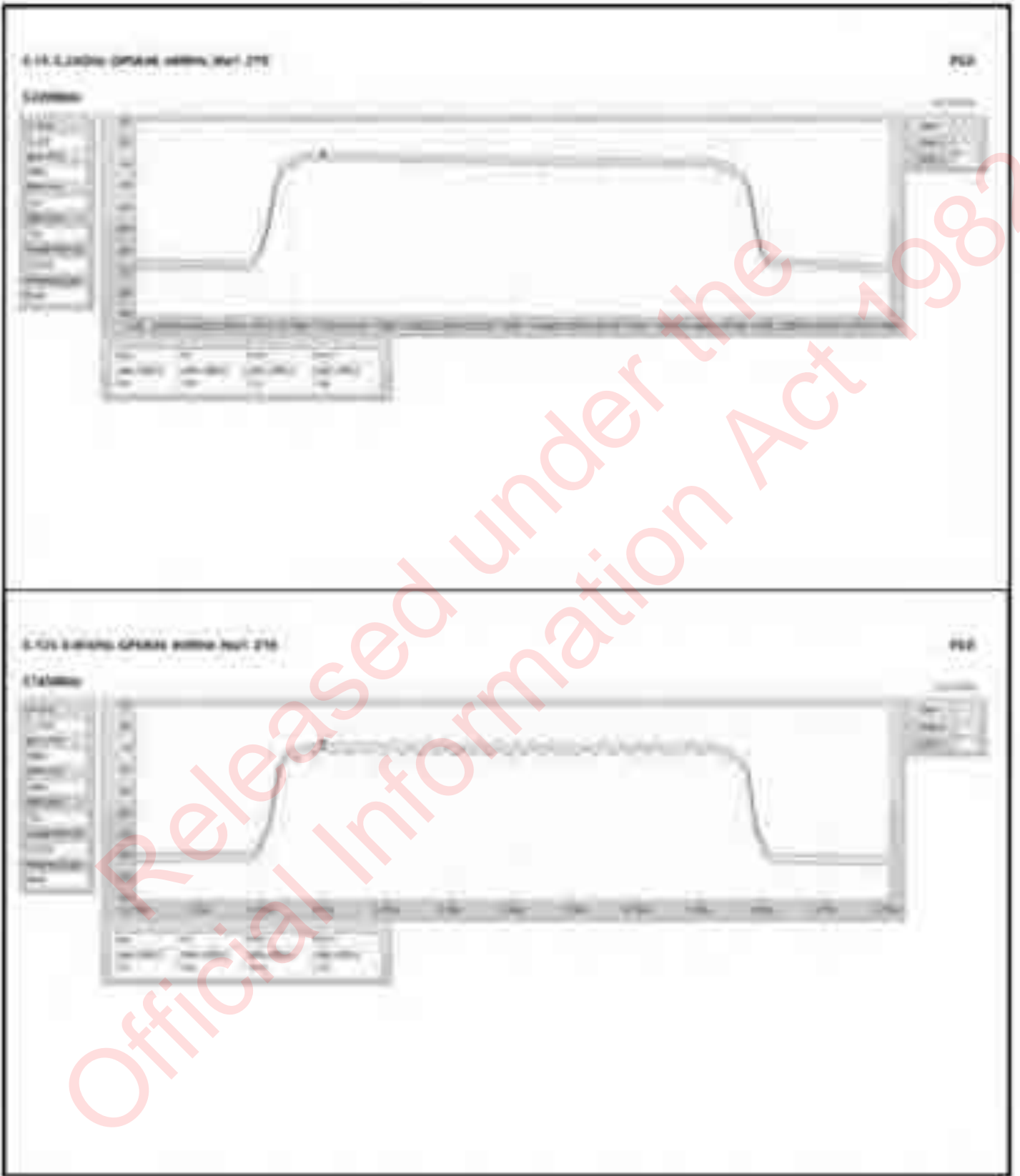





Summary

Mode	PD (dBm/RBW)
5.15-5.25GHz	-
QPSK20+20_20MHz+20MHz_Nss1_2TX(Port1&Port2)	-2.20
QPSK30+30_30MHz+30MHz_Nss1_2TX(Port1&Port2)	-2.15
QPSK40+40_40MHz+40MHz_Nss1_2TX(Port1&Port2)	-1.99
5.725-5.85GHz	-
QPSK20+20_20MHz+20MHz_Nss1_2TX(Port3&Port4)	-1.80
QPSK30+30_30MHz+30MHz_Nss1_2TX(Port3&Port4)	-2.94
QPSK40+40_40MHz+40MHz_Nss1_2TX(Port3&Port4)	-3.28

RBW = 500kHz for 5.725-5.85GHz band / 1MHz for other band;

Released under the Official Information Act 1982



Result

Mode	Result	DG (dBi)	Port 1 (dBm/RBW)	Port 2 (dBm/RBW)	Port 3 (dBm/RBW)	Port 4 (dBm/RBW)	PD (dBm/RBW)	PD Limit (dBm/RBW)
QPSK20+20_20MHz+20MHz_Nss1_2TX(Port1&Port2)	-	-	-	-	-	-	-	-
P#5180MHz,#5220MHz,5755MHz,5795MHz	Pass	15.962	-4.34	-5.07	-	-	-2.20	7.04
QPSK20+20_20MHz+20MHz_Nss1_2TX(Port3&Port4)	-	-	-	-	-	-	-	-
P5180MHz,5220MHz,#5755MHz,#5795MHz	Pass	15.958	-	-	-5.08	-4.23	-1.80	20.04
QPSK30+30_30MHz+30MHz_Nss1_2TX(Port1&Port2)	-	-	-	-	-	-	-	-
P#5180MHz,#5220MHz,5755MHz,5795MHz	Pass	15.962	-4.67	-5.65	-	-	-2.15	7.04
QPSK30+30_30MHz+30MHz_Nss1_2TX(Port3&Port4)	-	-	-	-	-	-	-	-
P5180MHz,5220MHz,#5755MHz,#5795MHz	Pass	15.958	-	-	-5.86	-5.92	-2.94	20.04
QPSK40+40_40MHz+40MHz_Nss1_2TX(Port1&Port2)	-	-	-	-	-	-	-	-
P#5175MHz,#5225MHz,5750MHz,5800MHz	Pass	15.962	-4.53	-5.51	-	-	-1.99	7.04
QPSK40+40_40MHz+40MHz_Nss1_2TX(Port3&Port4)	-	-	-	-	-	-	-	-
P5175MHz,5225MHz,#5750MHz,#5800MHz	Pass	15.958	-	-	-5.67	-5.57	-3.28	20.04

DG = Directional Gain; RBW = 500kHz for 5.725-5.85GHz band / 1MHz for other band;
 PD = trace bin-by-bin of each transmits port summing can be performed maximum power density; Port X = Port X Power Density;

Released under the
 Official Information Act 1982





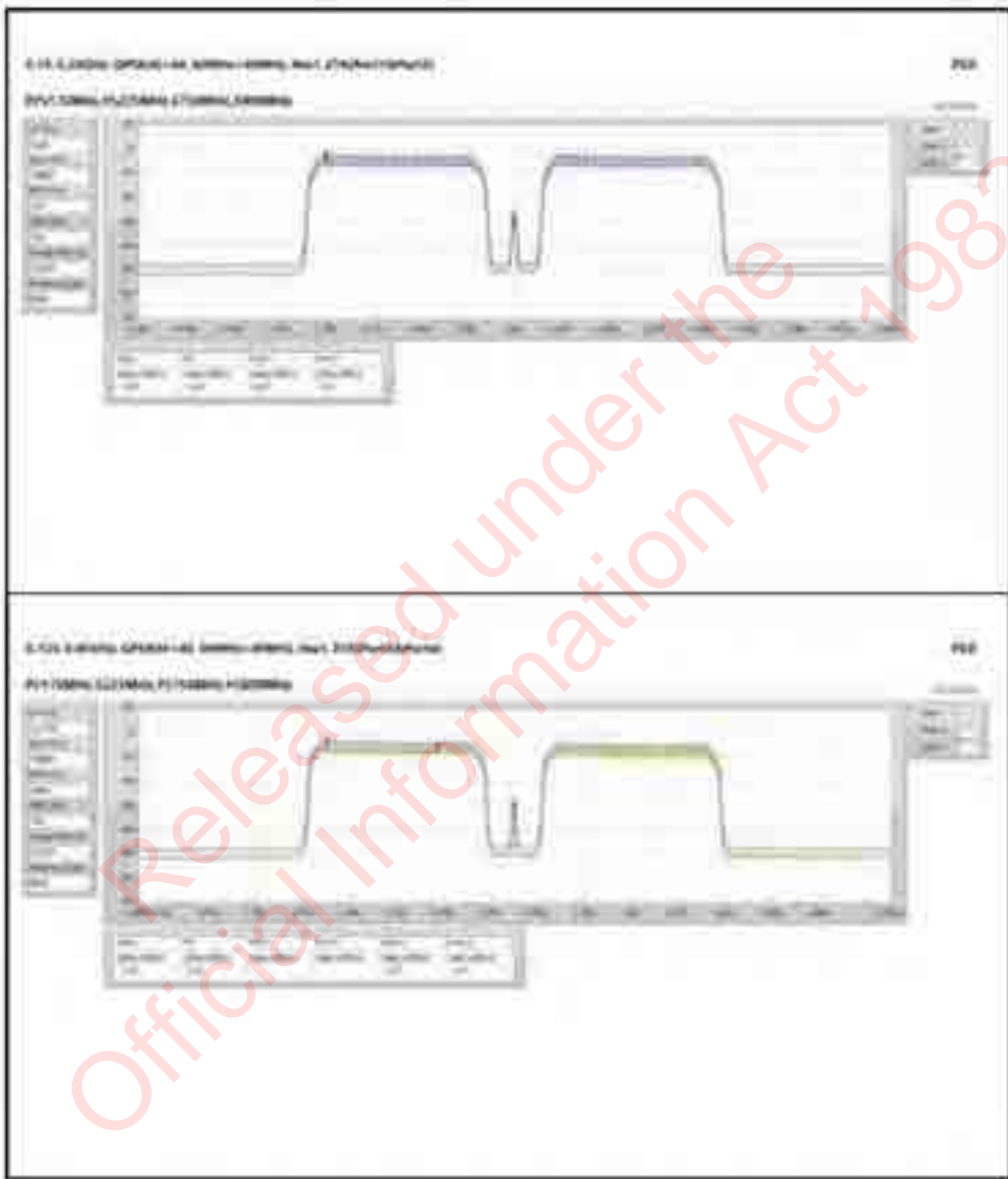



Summary

Mode	Result	Type	Freq (Hz)	Level (dBuV/m)	Limit (dBuV/m)	Margin (dB)	Condition
Mode 1	Pass	PK	45.04M	37.40	40.00	-2.60	Vertical

Released under the Official Information Act 1982



Released under the Official Information Act 1982



Released under the Official Information Act 1982



Summary

Mode	Result	Type	Freq (Hz)	Level (dBuV/m)	Limit (dBuV/m)	Margin (dB)	Dist (m)	Condition	Azimuth (°)	Height (m)	Comments
5.725-5.85GHz	-	-	-	-	-	-	-	-	-	-	-
QPSK15_15MHz_Nss1_2TX	Pass	AV	5.375G	53.96	54.00	-0.04	3	Vertical	353	1.74	-

Released under the Official Information Act 1982

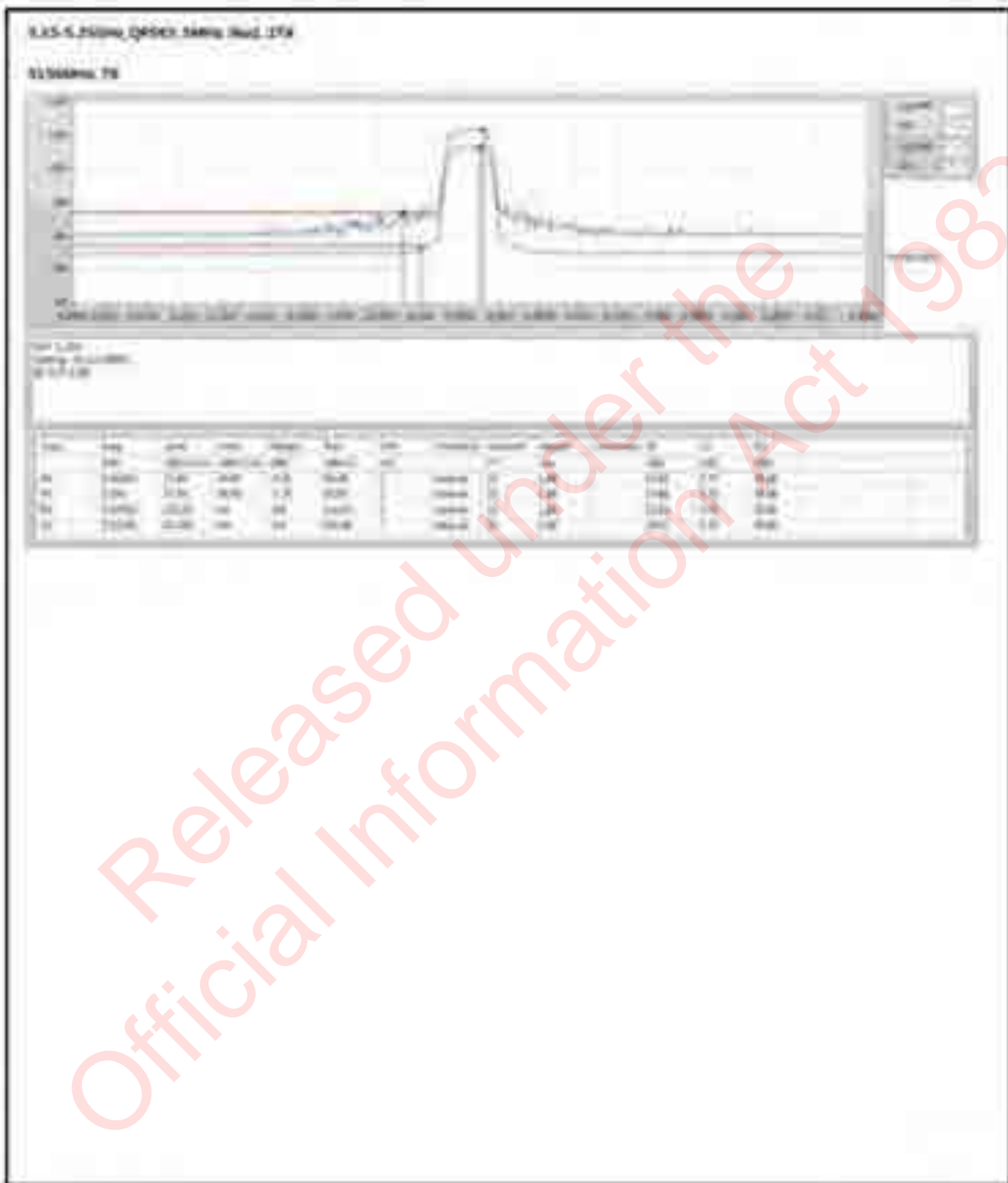

Released under the
Official Information Act 1982

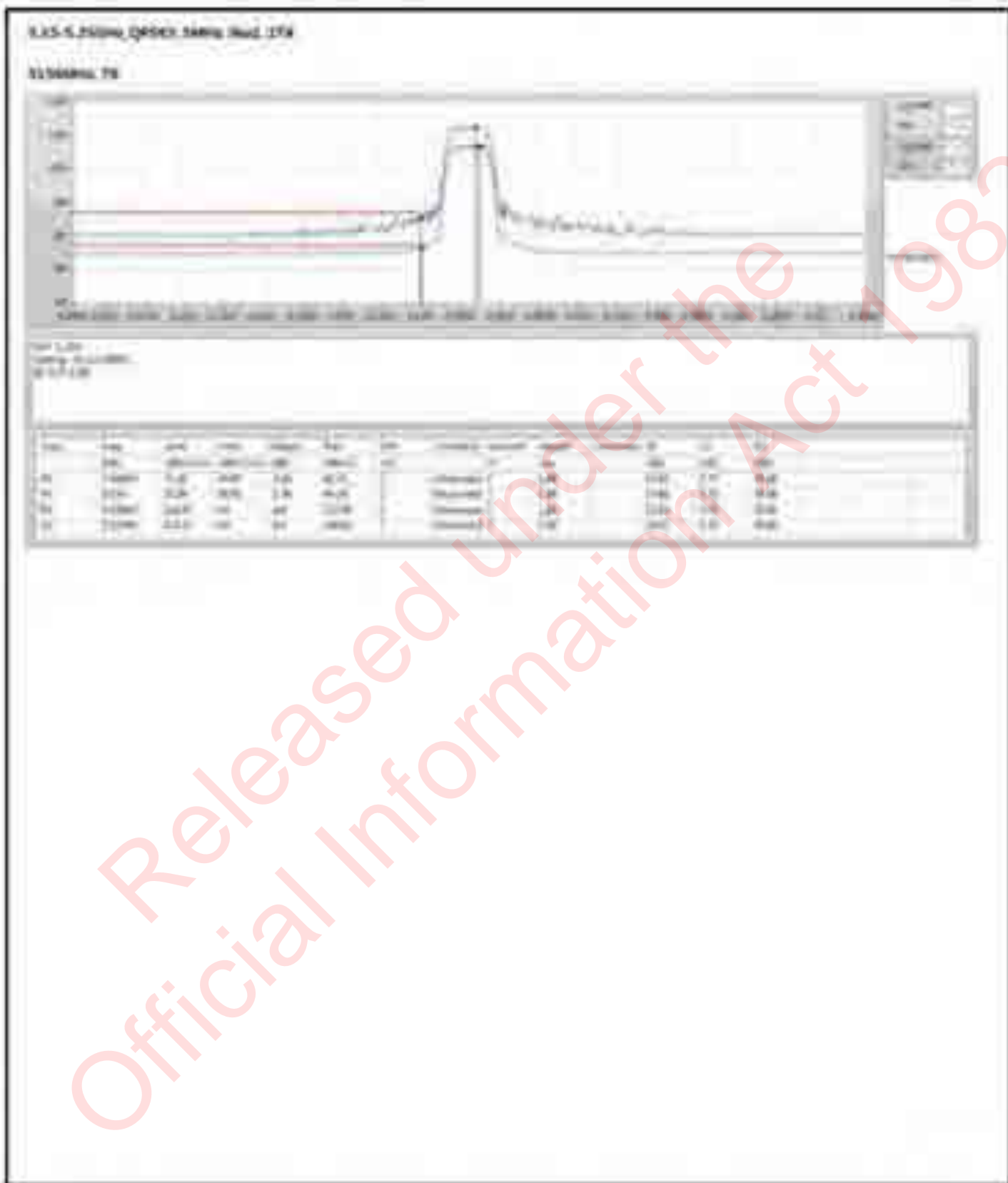

Released under the
Official Information Act 1982



Released under the Official Information Act 1982



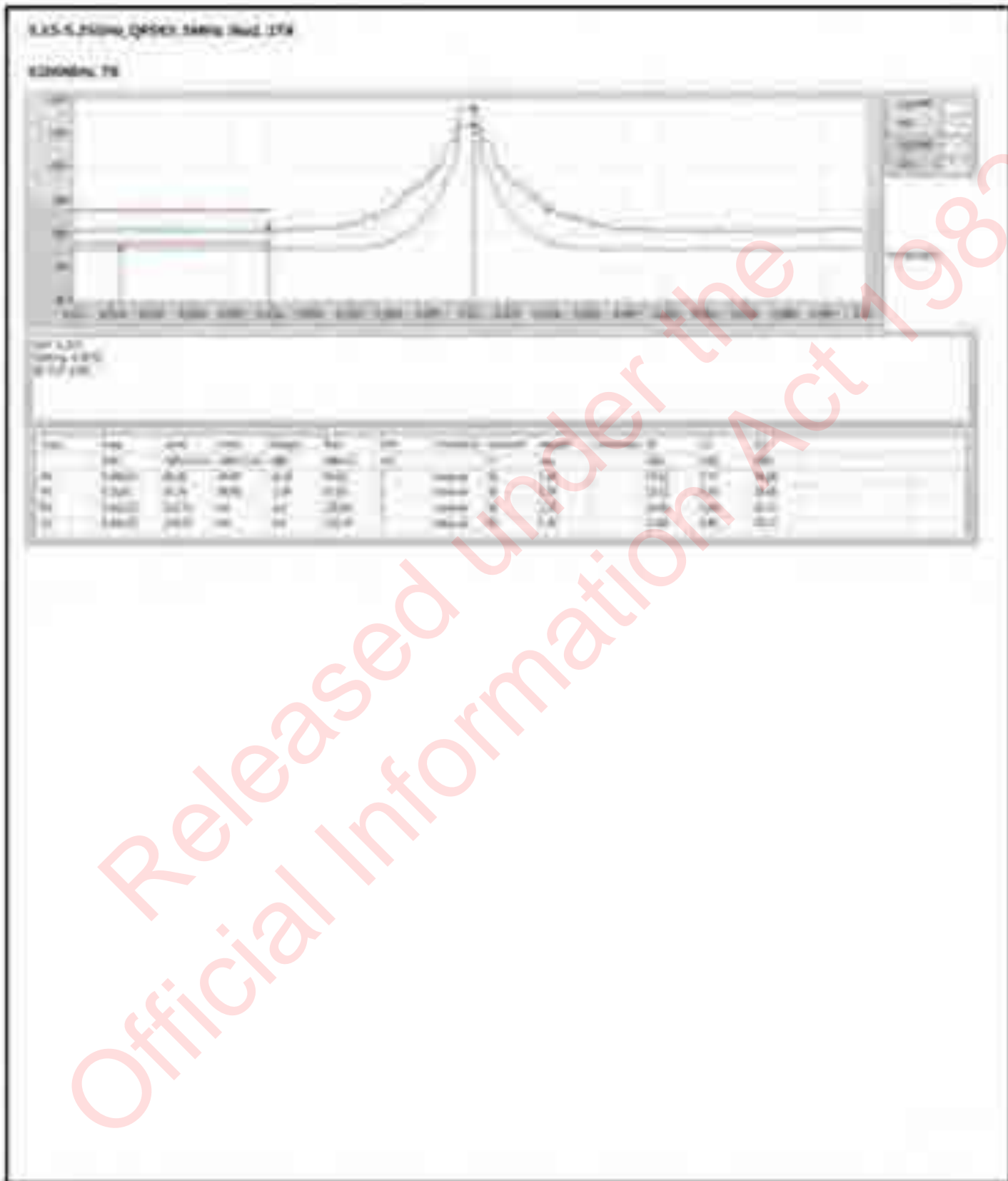

Released under the Official Information Act 1982

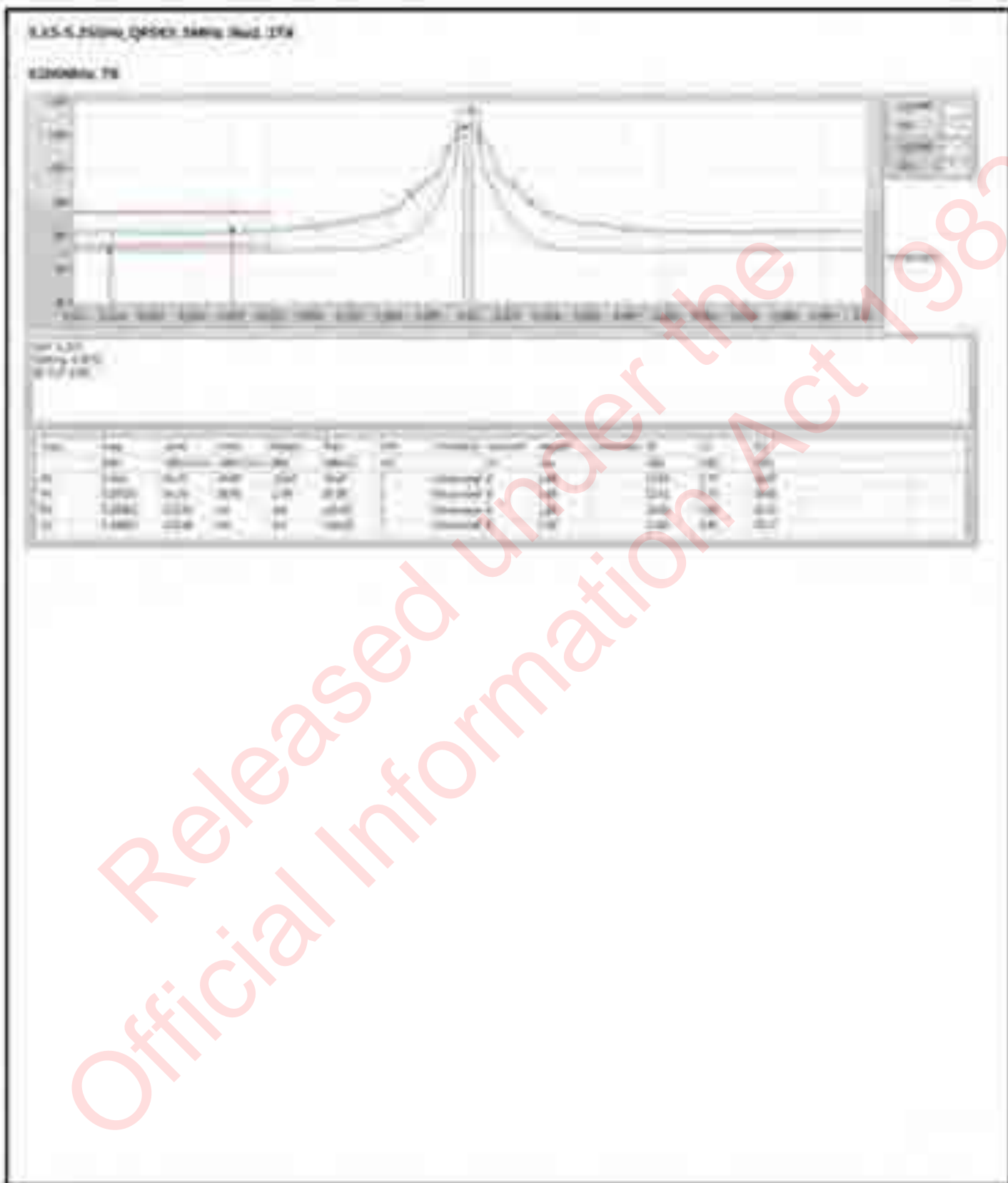

Released under the
Official Information Act 1982



Released under the Official Information Act 1982







Released under the Official Information Act 1982



Released under the Official Information Act 1982



Released under the
Official Information Act 1982

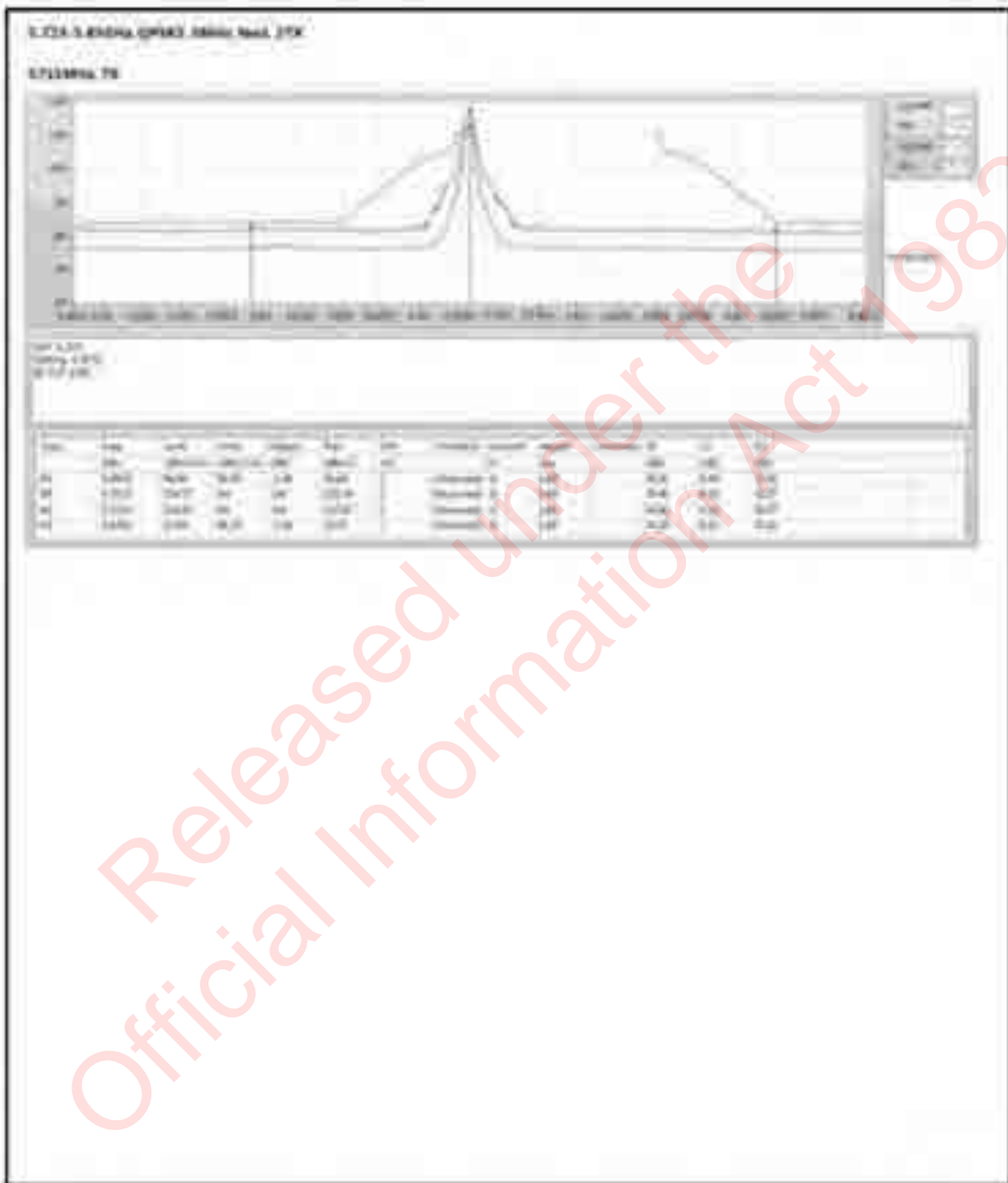

Released under the
Official Information Act 1982



Released under the Official Information Act 1982



Released under the Official Information Act 1982



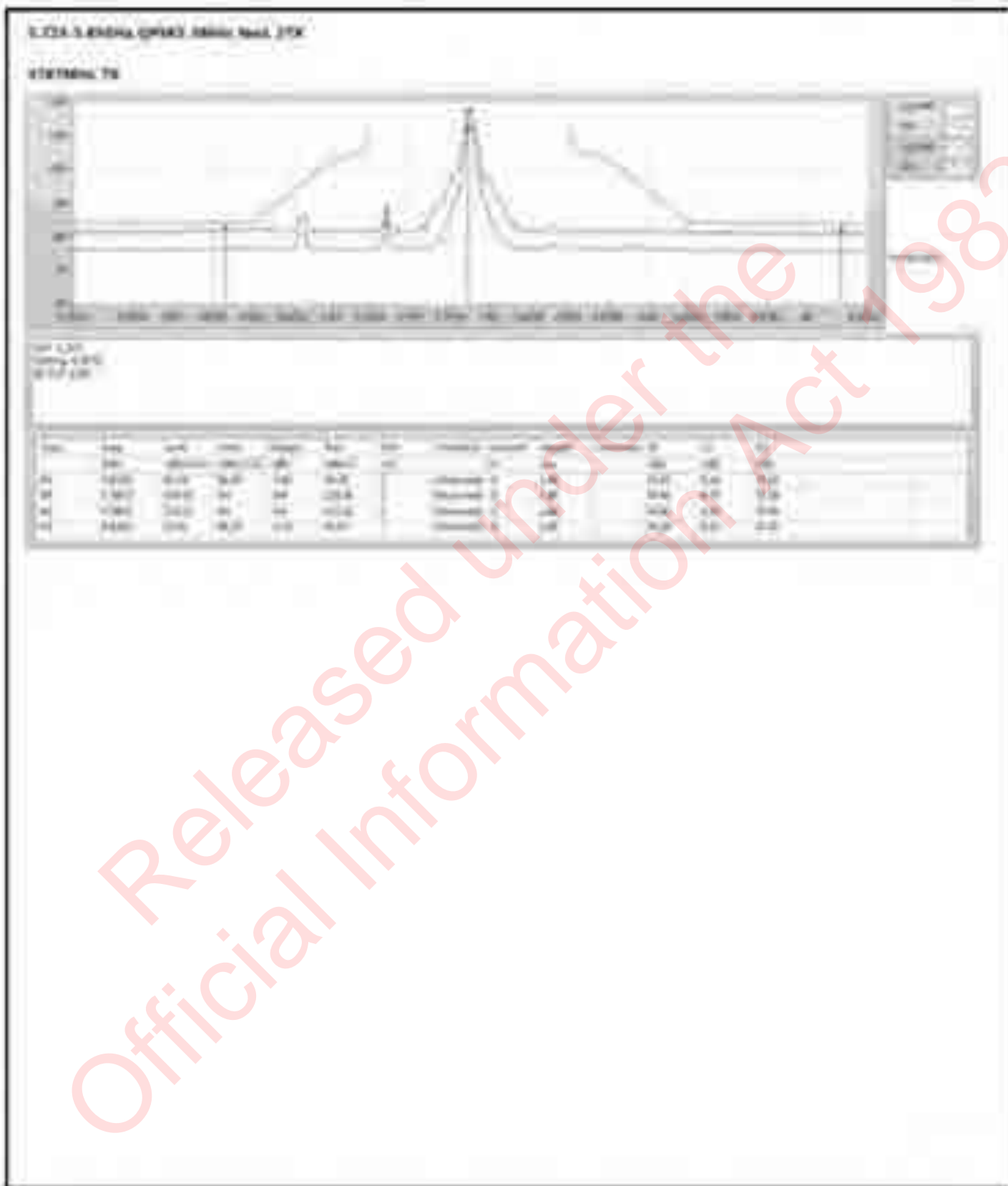



Released under the
Official Information Act 1982



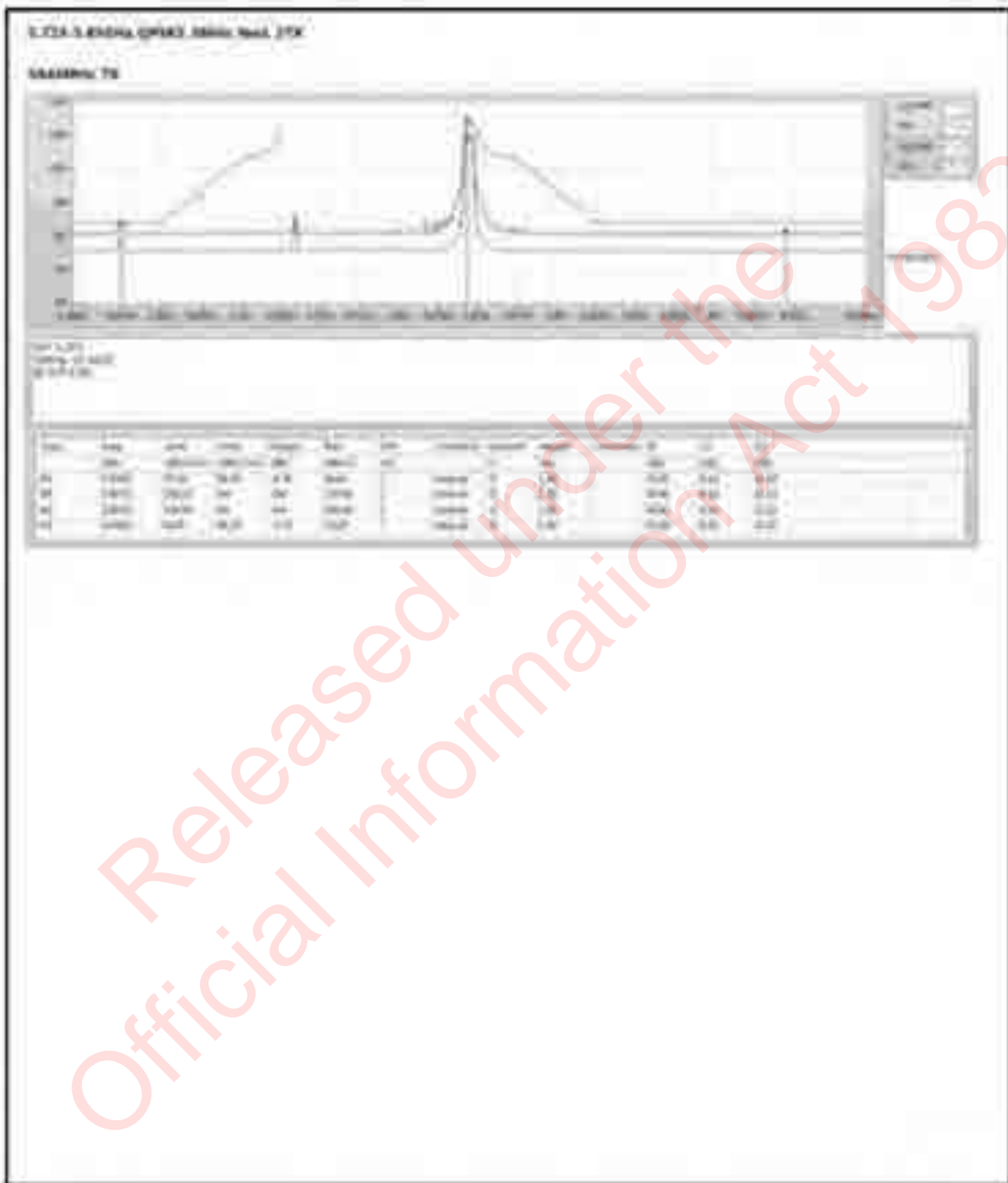

Released under the
Official Information Act 1982







Released under the Official Information Act 1982



Released under the
Official Information Act 1982







Released under the Official Information Act 1982

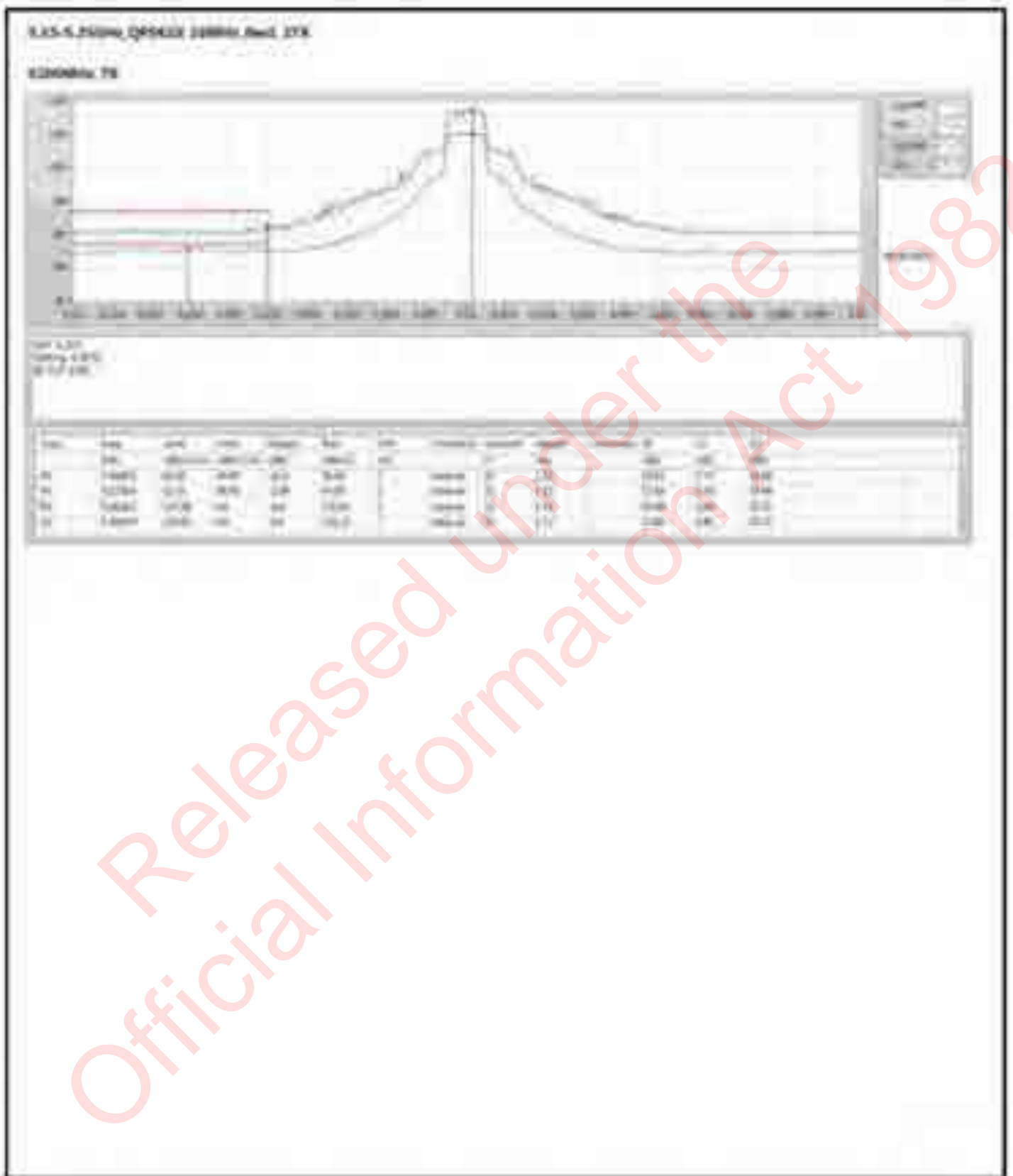

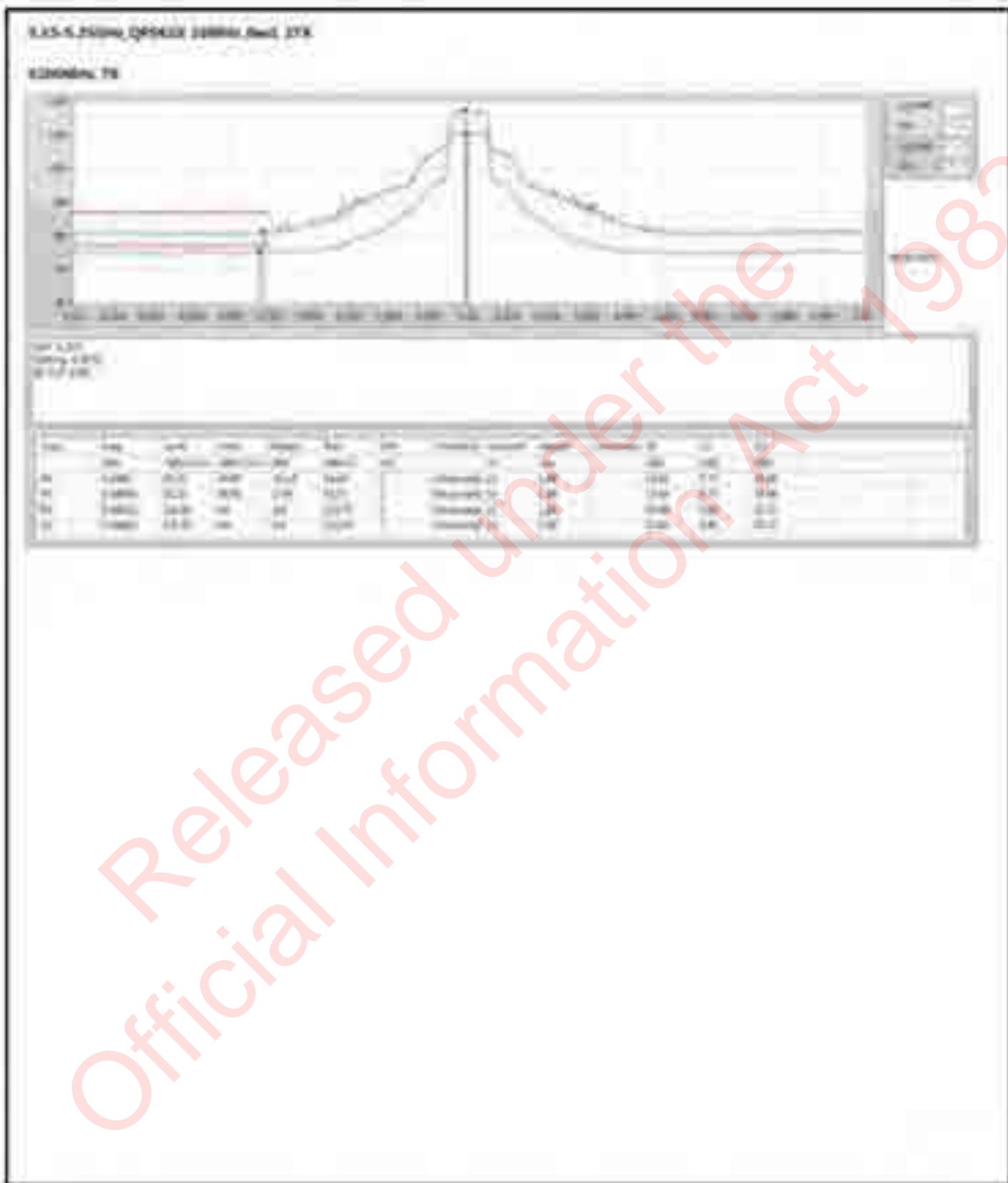

Released under the
Official Information Act 1982





Released under the Official Information Act 1982

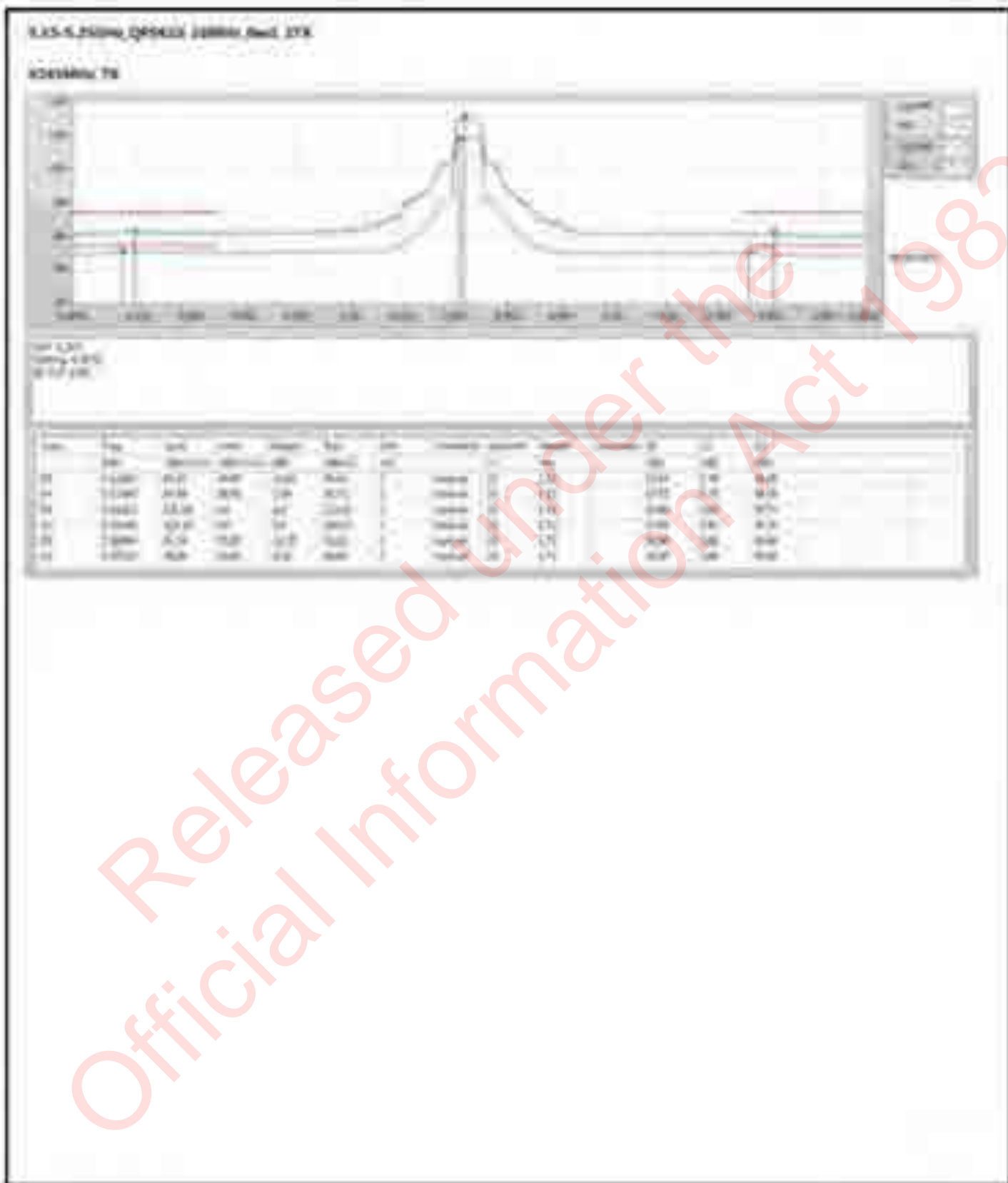

Released under the Official Information Act 1982





Released under the Official Information Act 1982



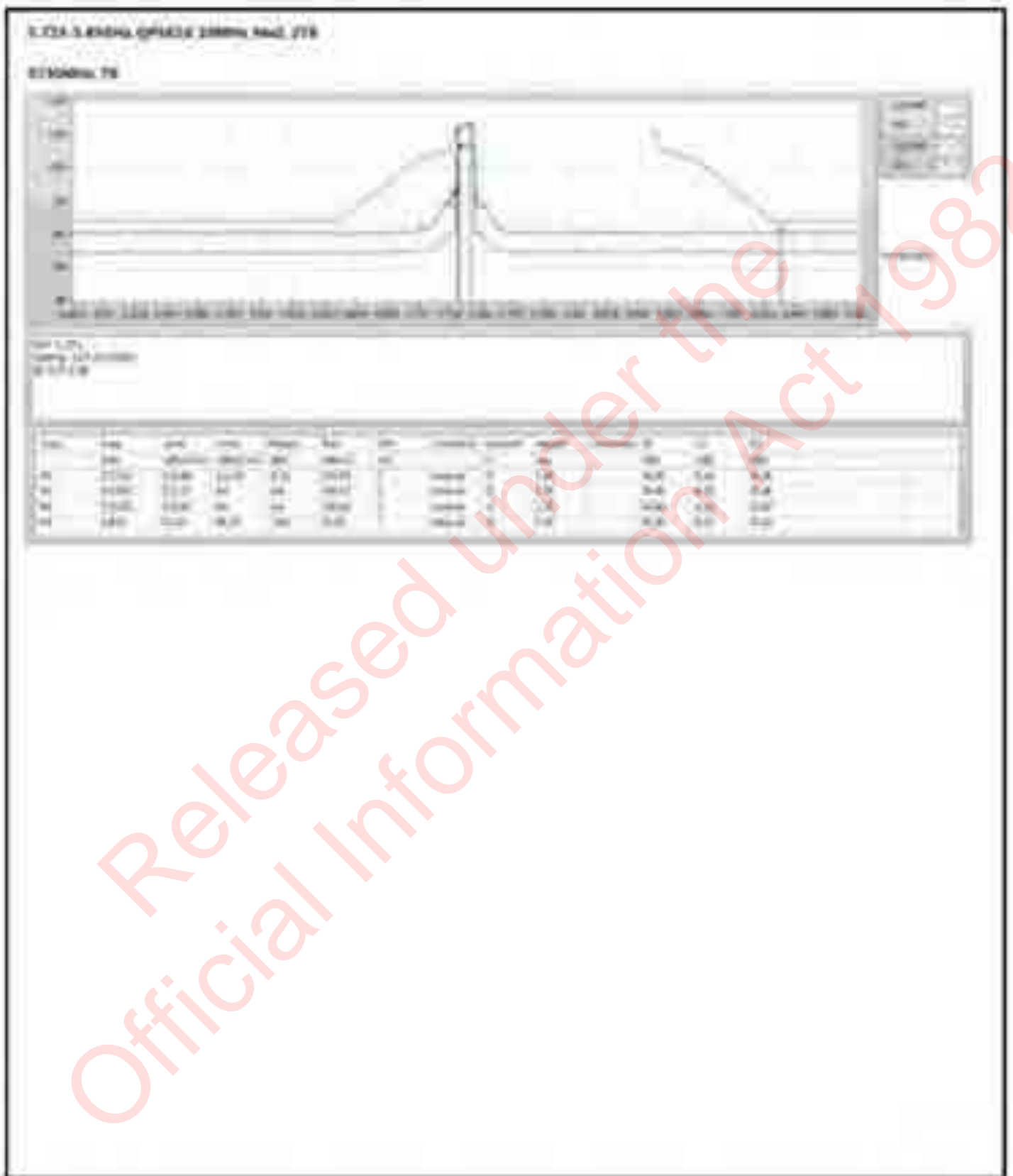

Released under the
Official Information Act 1982

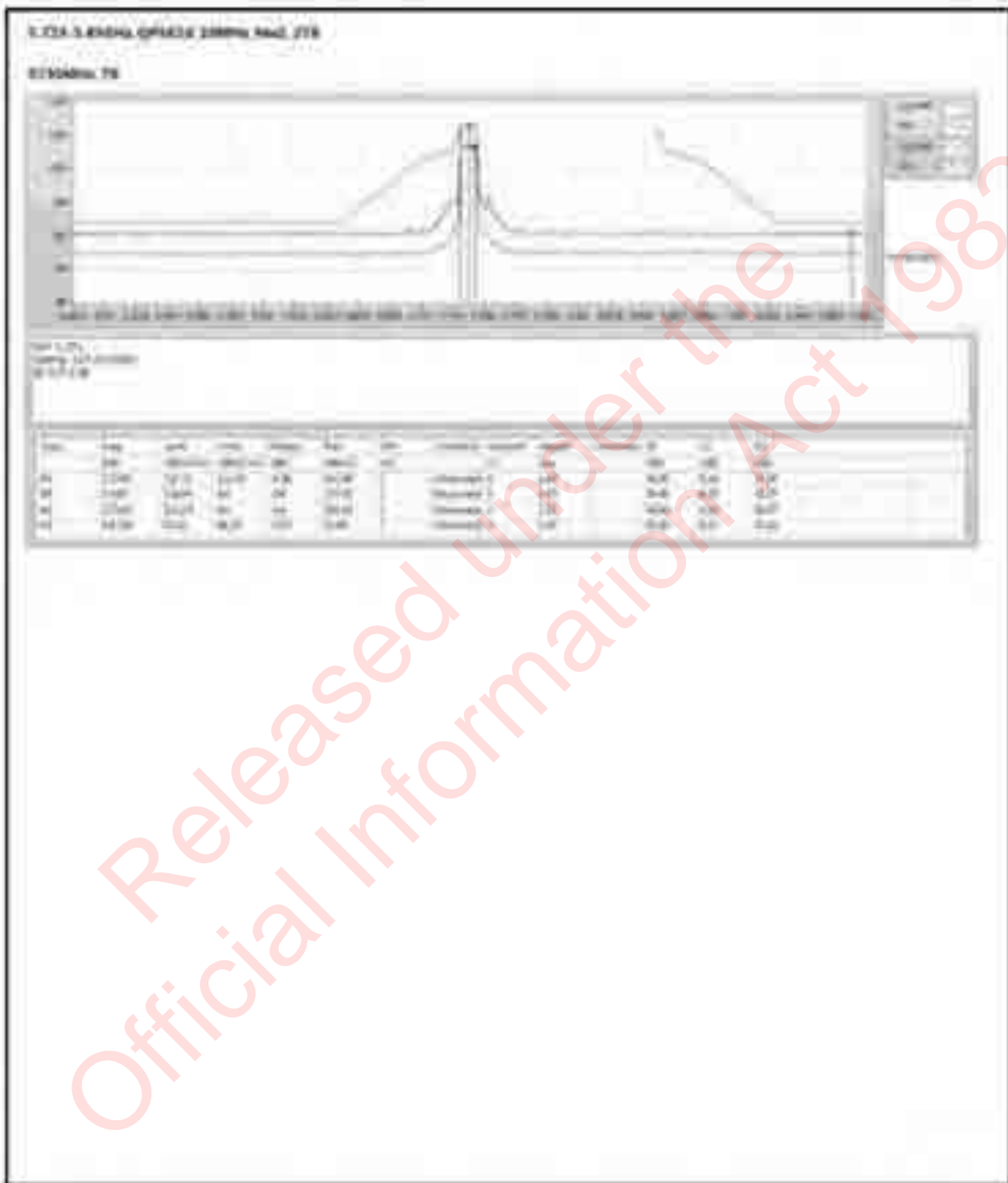



Released under the Official Information Act 1982



Released under the Official Information Act 1982



5.724.5.825MHz (OFFLINE) 200MHz MAG 0.7dB

STANDARD TEST

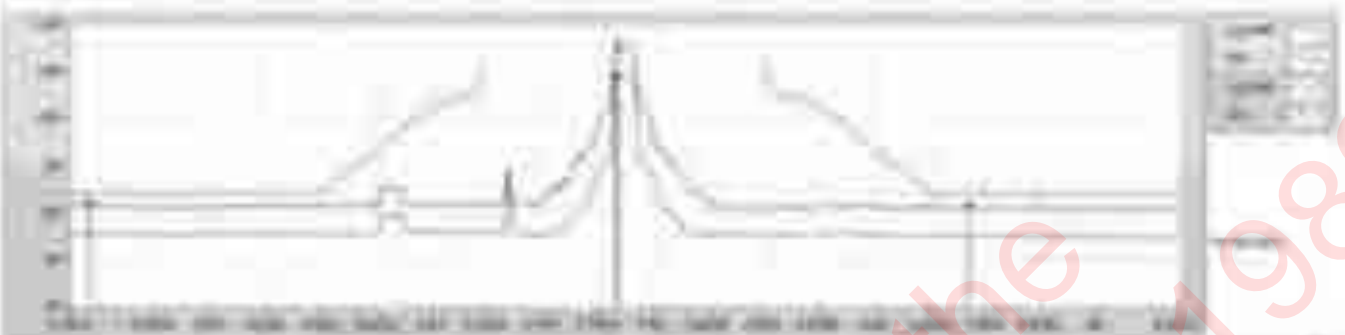

OFFLINE
200MHz MAG
0.7dB

Frequency (MHz)	Power (dBm)	Bandwidth (MHz)	Modulation	Symbol Rate (baud)	Constellation	BER	QoS	QoS	QoS
5.724.5825	-100	200	QPSK	10000	16-QAM	0.0001	0.0001	0.0001	0.0001
5.724.5825	-100	200	QPSK	10000	16-QAM	0.0001	0.0001	0.0001	0.0001
5.724.5825	-100	200	QPSK	10000	16-QAM	0.0001	0.0001	0.0001	0.0001
5.724.5825	-100	200	QPSK	10000	16-QAM	0.0001	0.0001	0.0001	0.0001

Released under the Official Information Act 1982

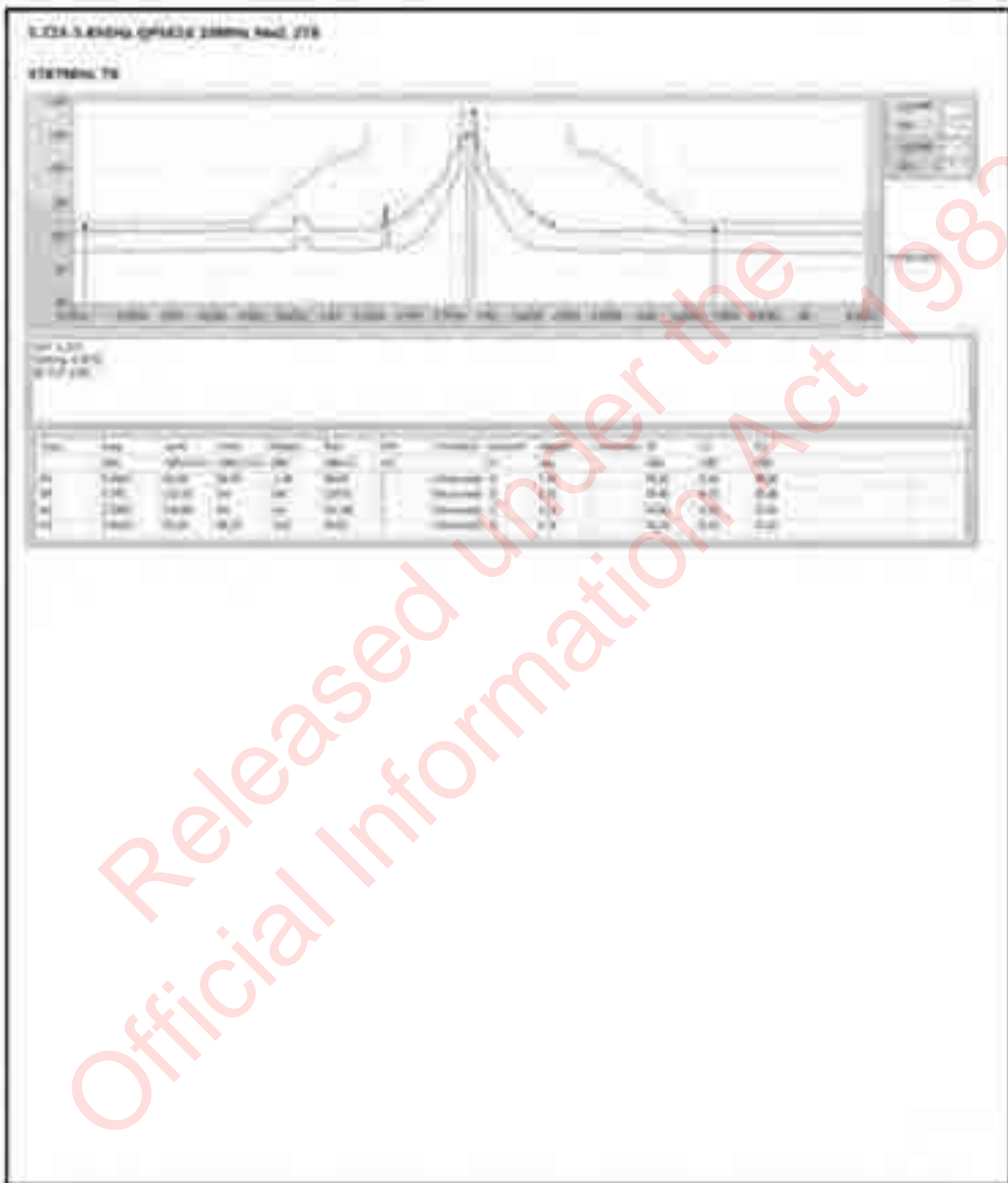

Released under the
Official Information Act 1982



Released under the Official Information Act 1982



Released under the Official Information Act 1982

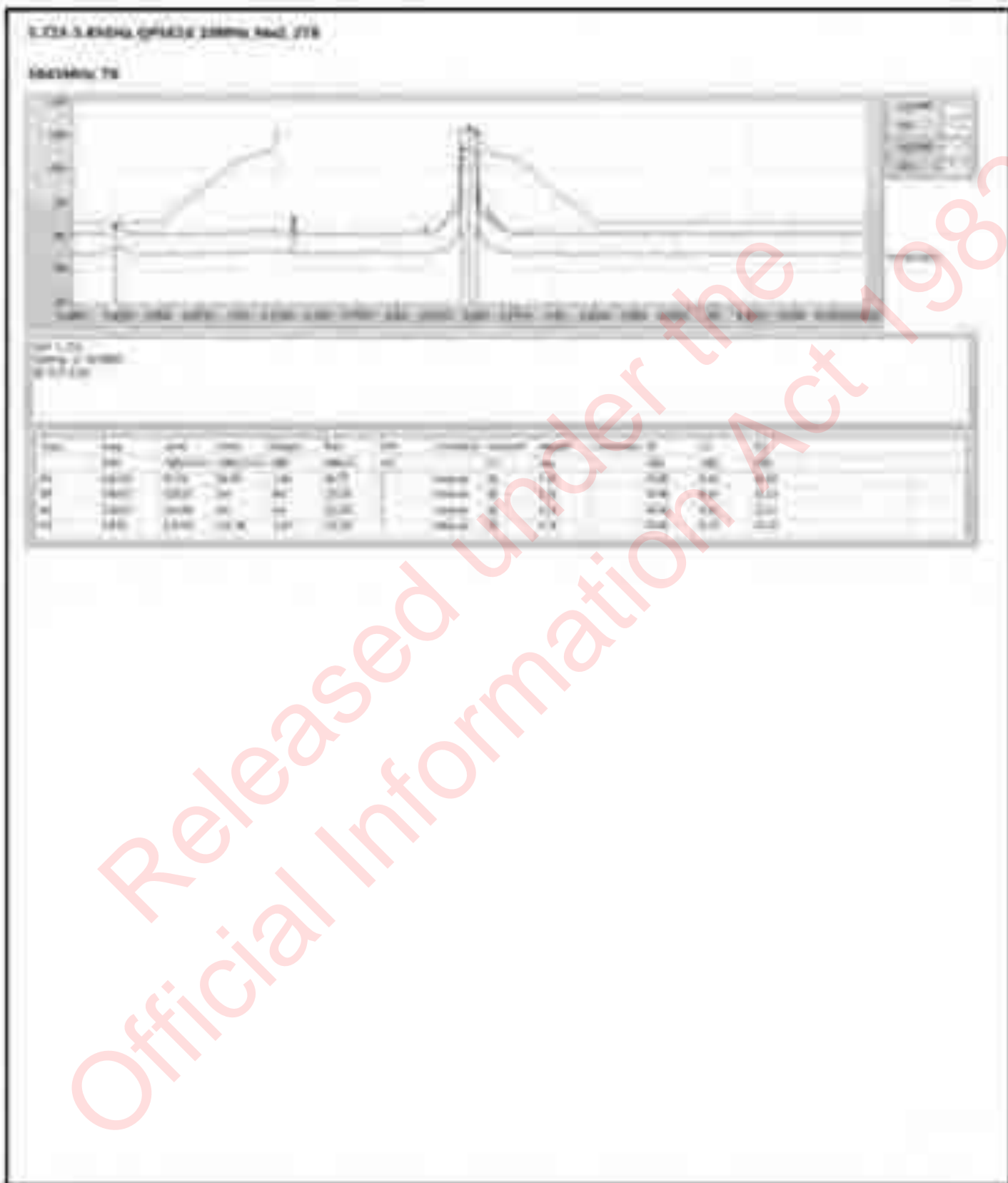

Released under the
Official Information Act 1982

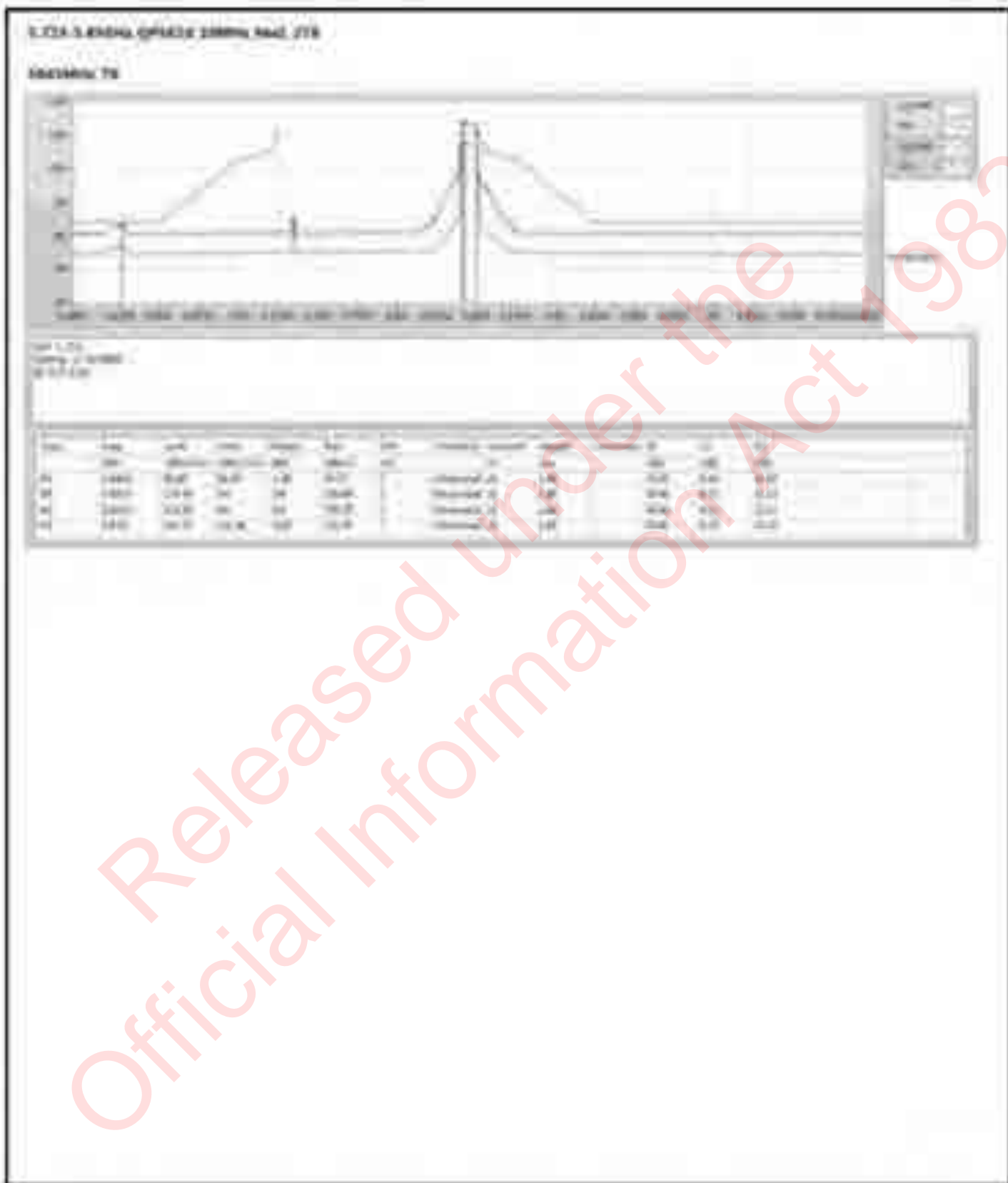



Released under the
Official Information Act 1982



Released under the Official Information Act 1982

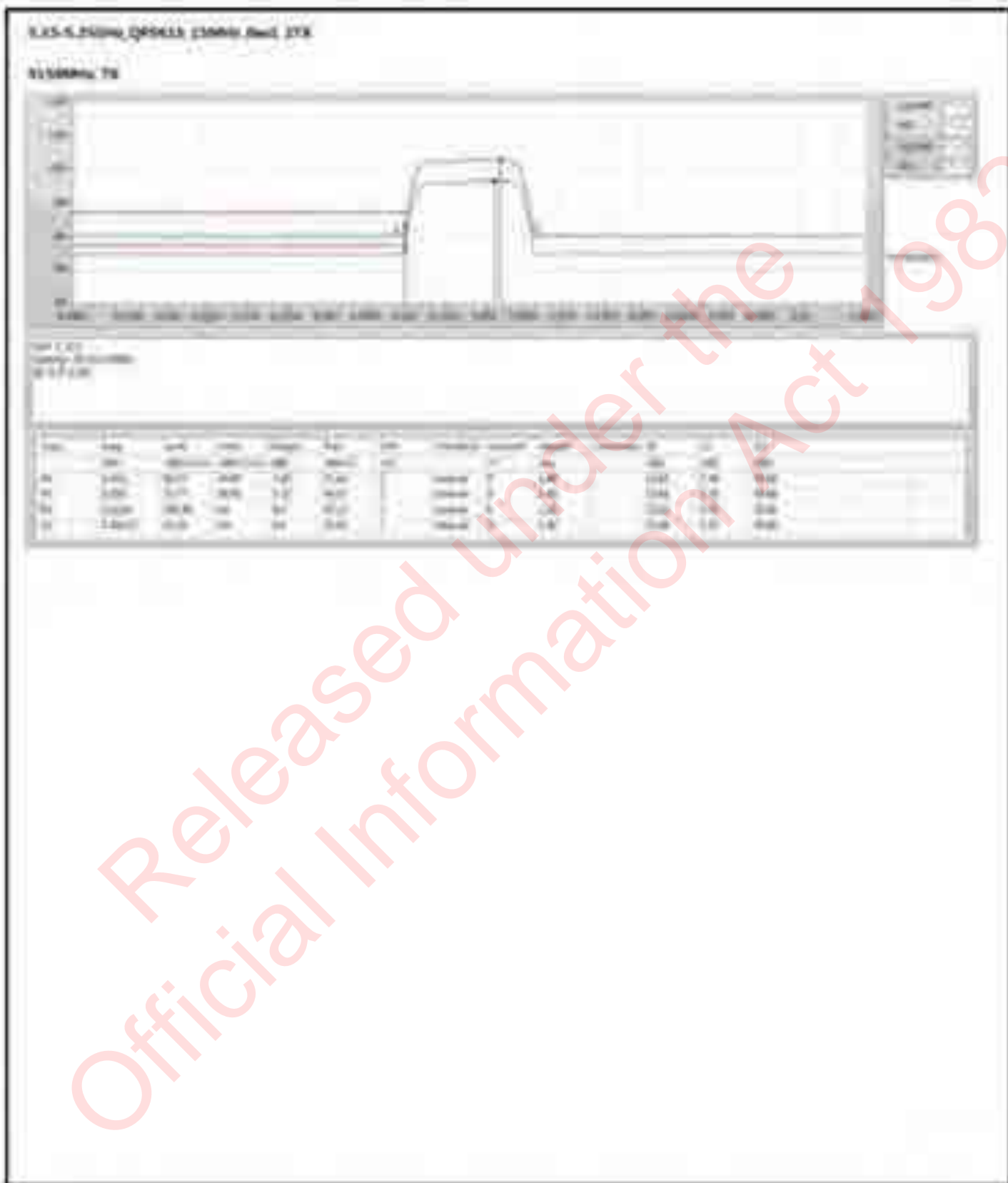

Released under the
Official Information Act 1982







Released under the Official Information Act 1982

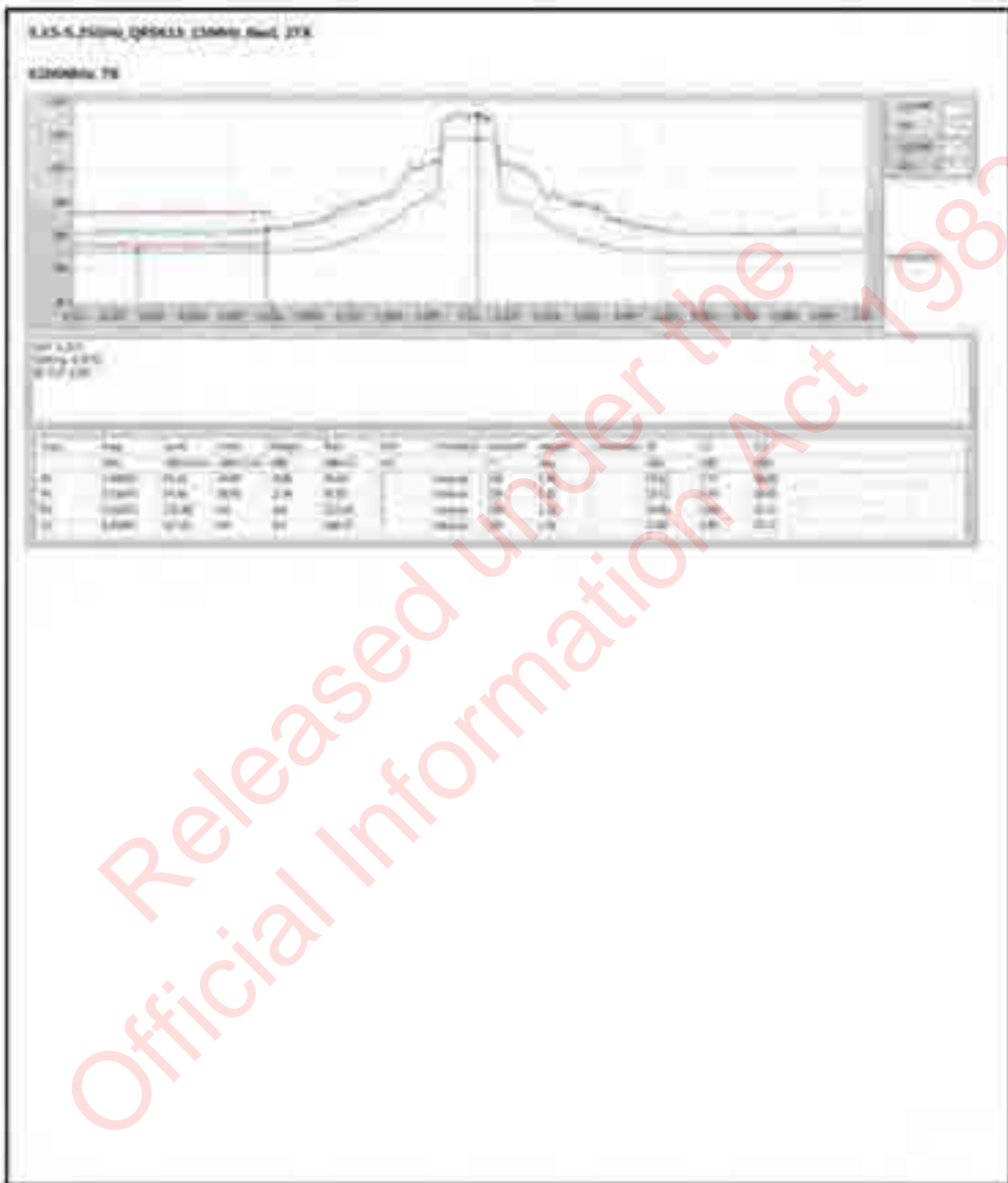

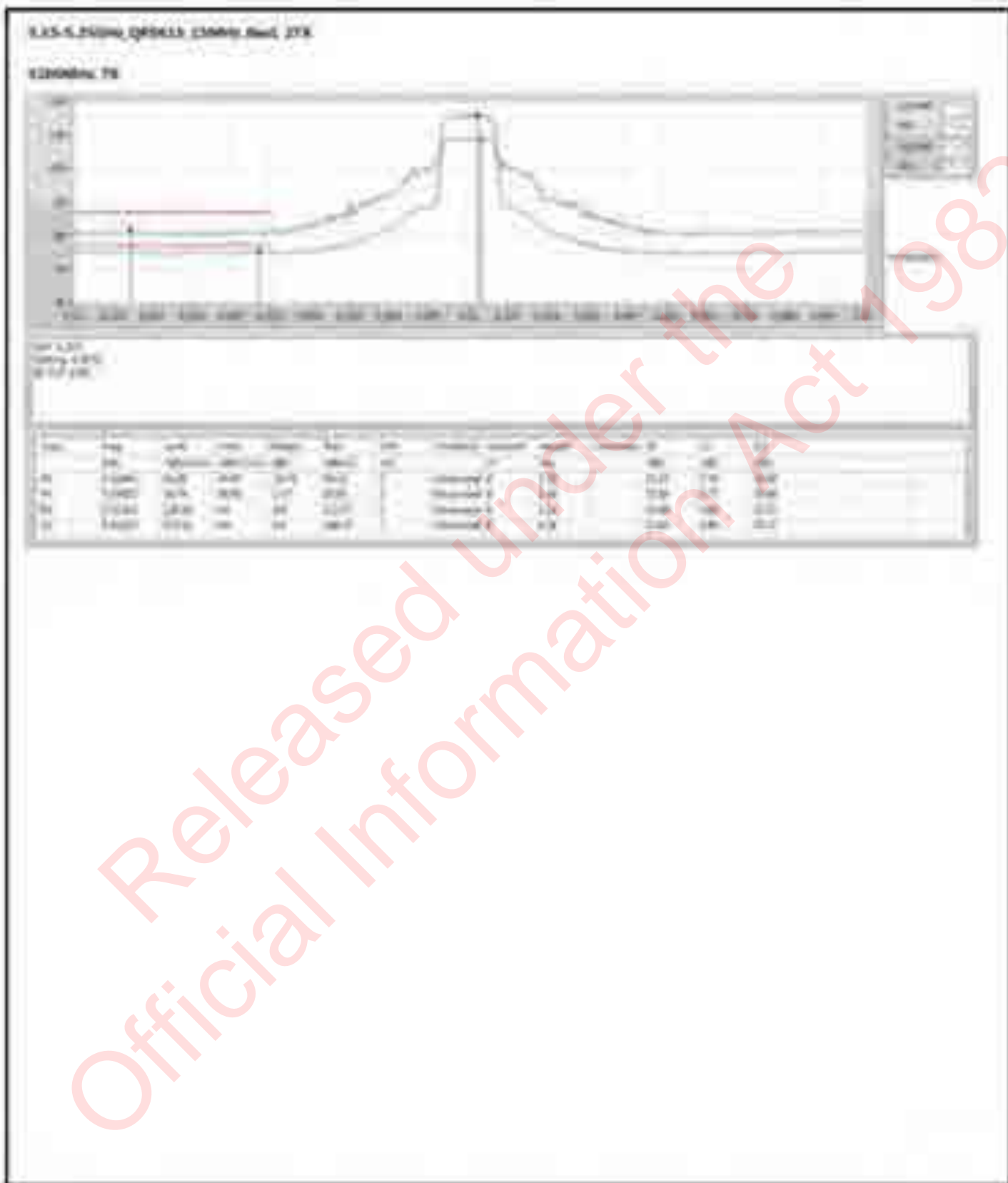







Released under the Official Information Act 1982

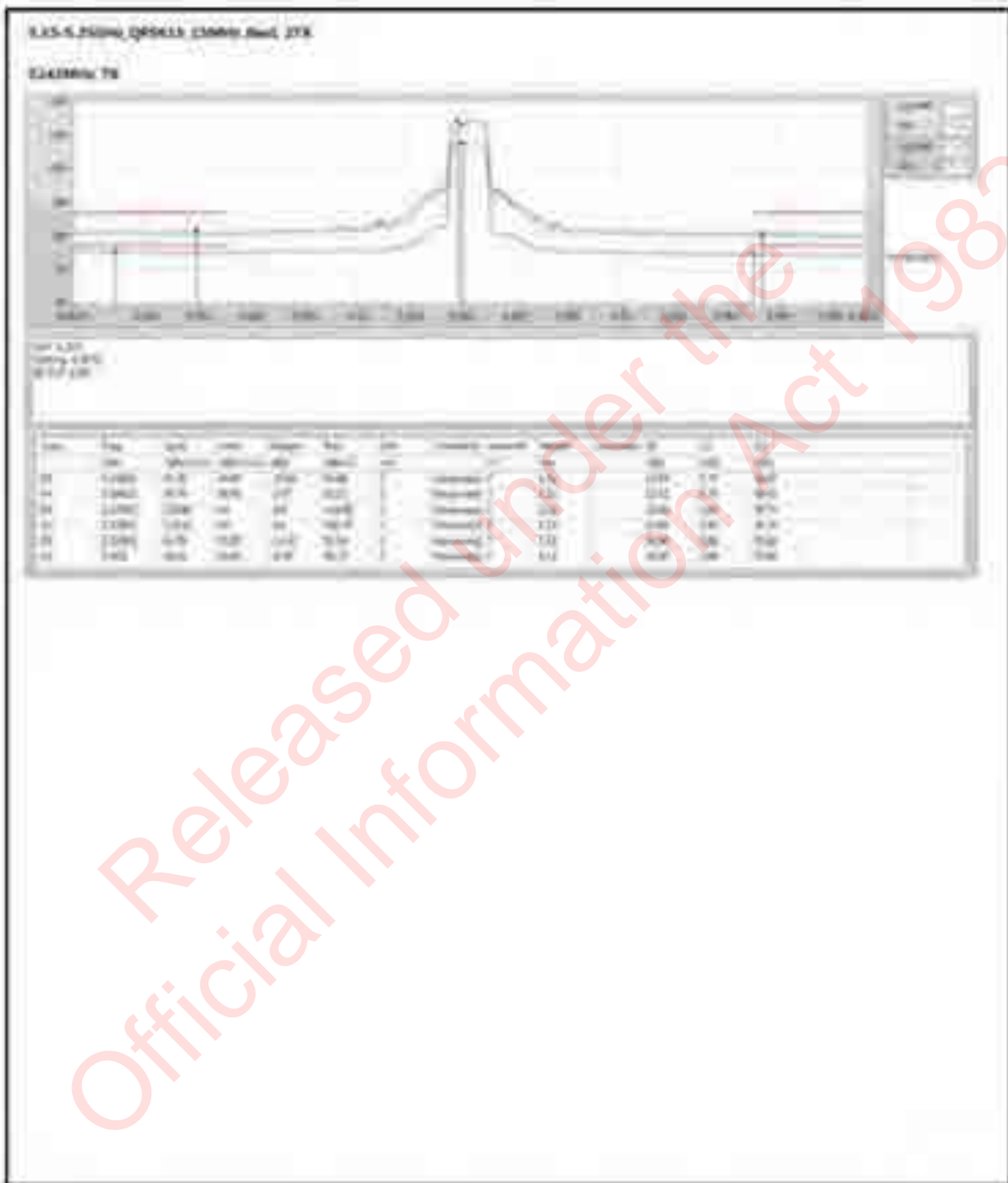







Released under the Official Information Act 1982



Released under the Official Information Act 1982



Released under the Official Information Act 1982



Released under the
Official Information Act 1982

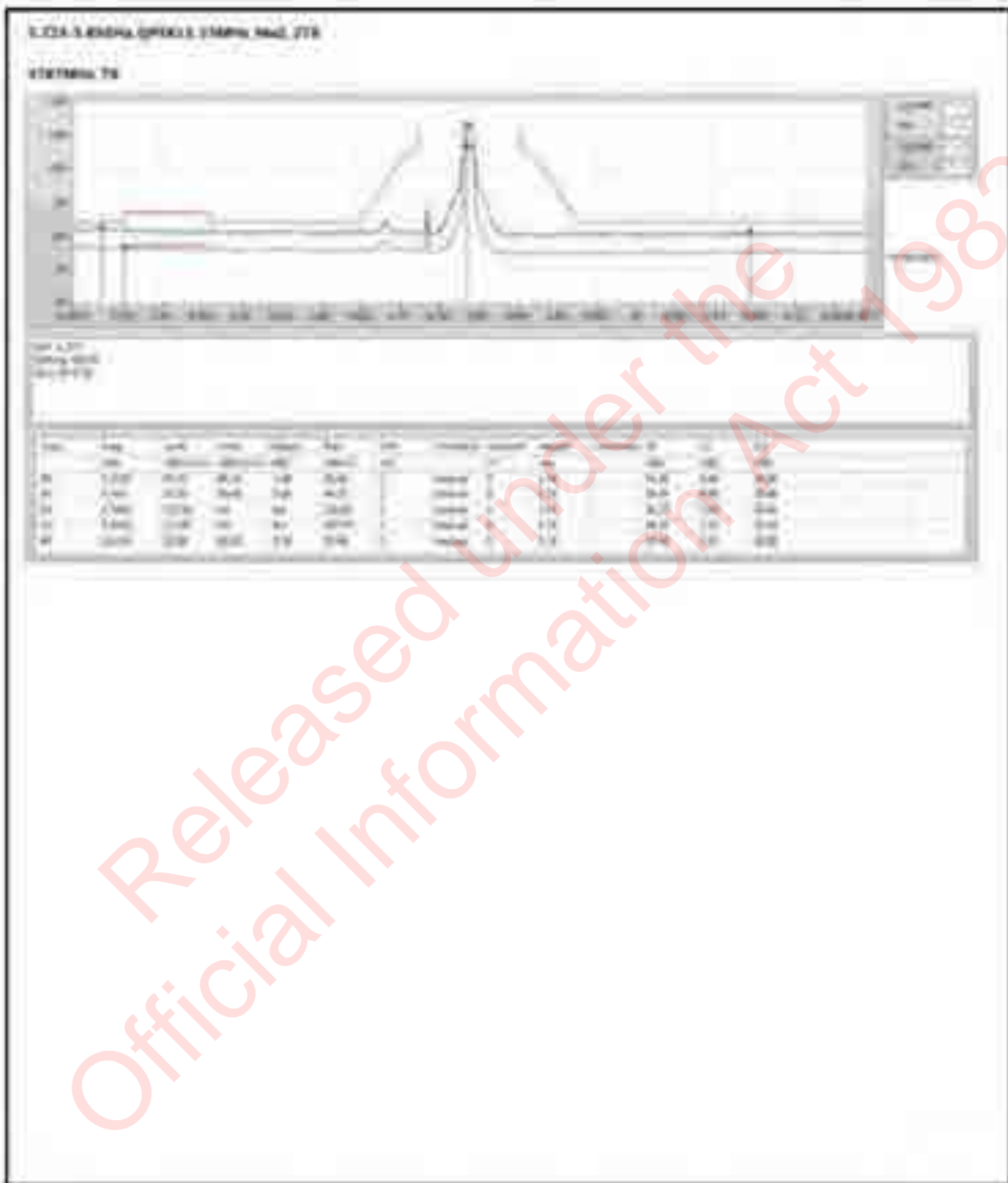

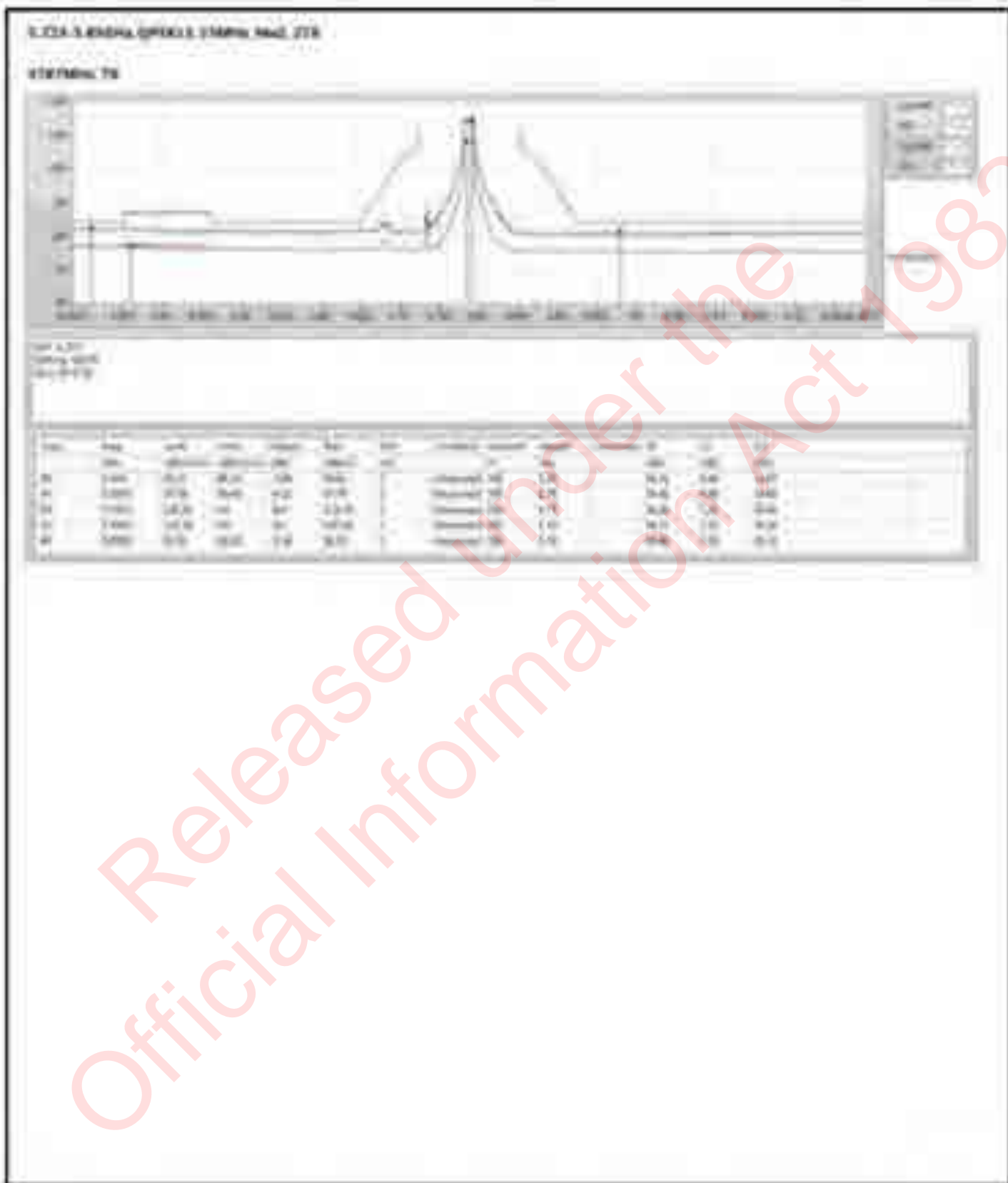



Released under the Official Information Act 1982



Released under the
Official Information Act 1982

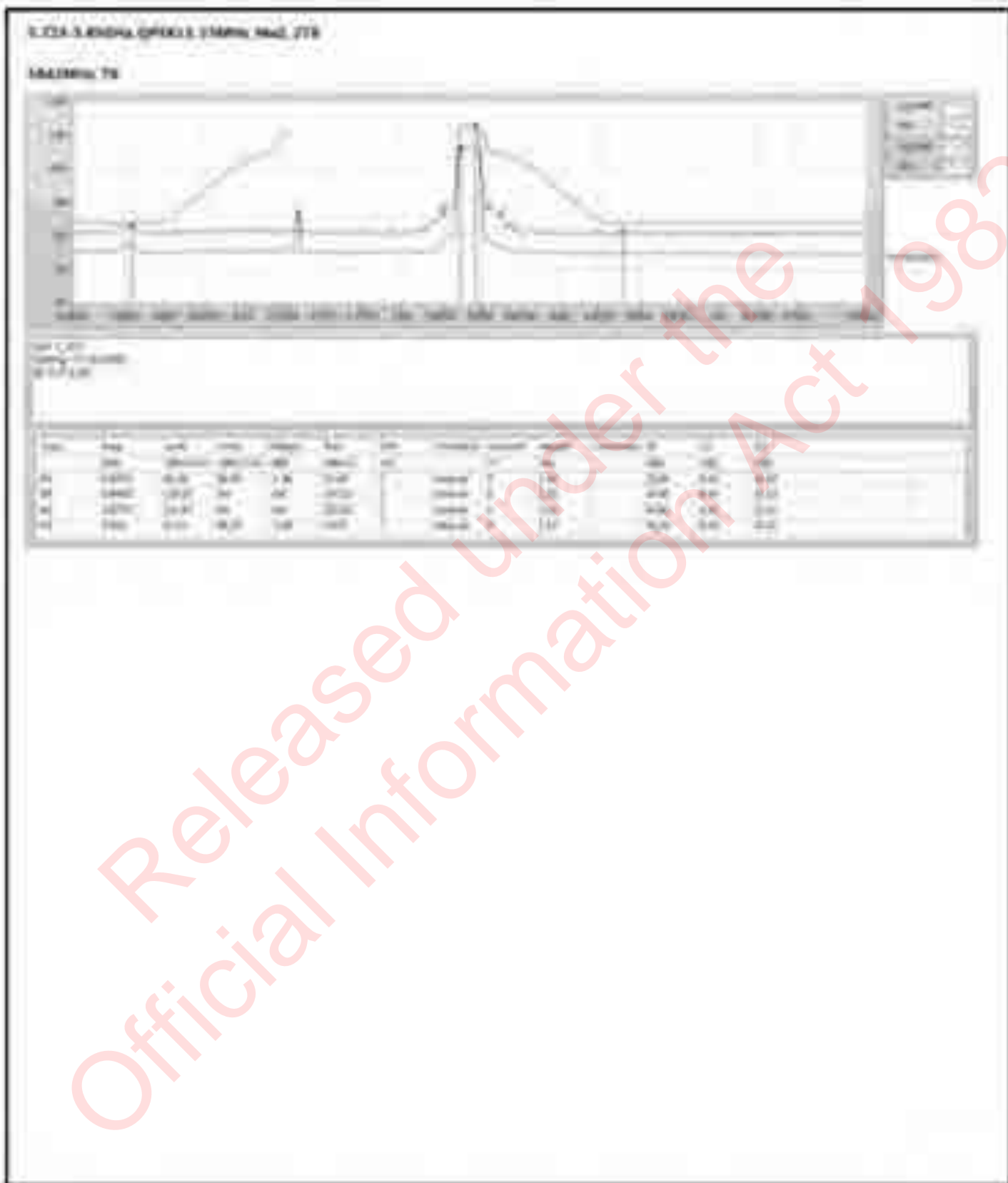







Released under the Official Information Act 1982









Released under the Official Information Act 1982



Released under the
Official Information Act 1982







Released under the
Official Information Act 1982



Released under the Official Information Act 1982

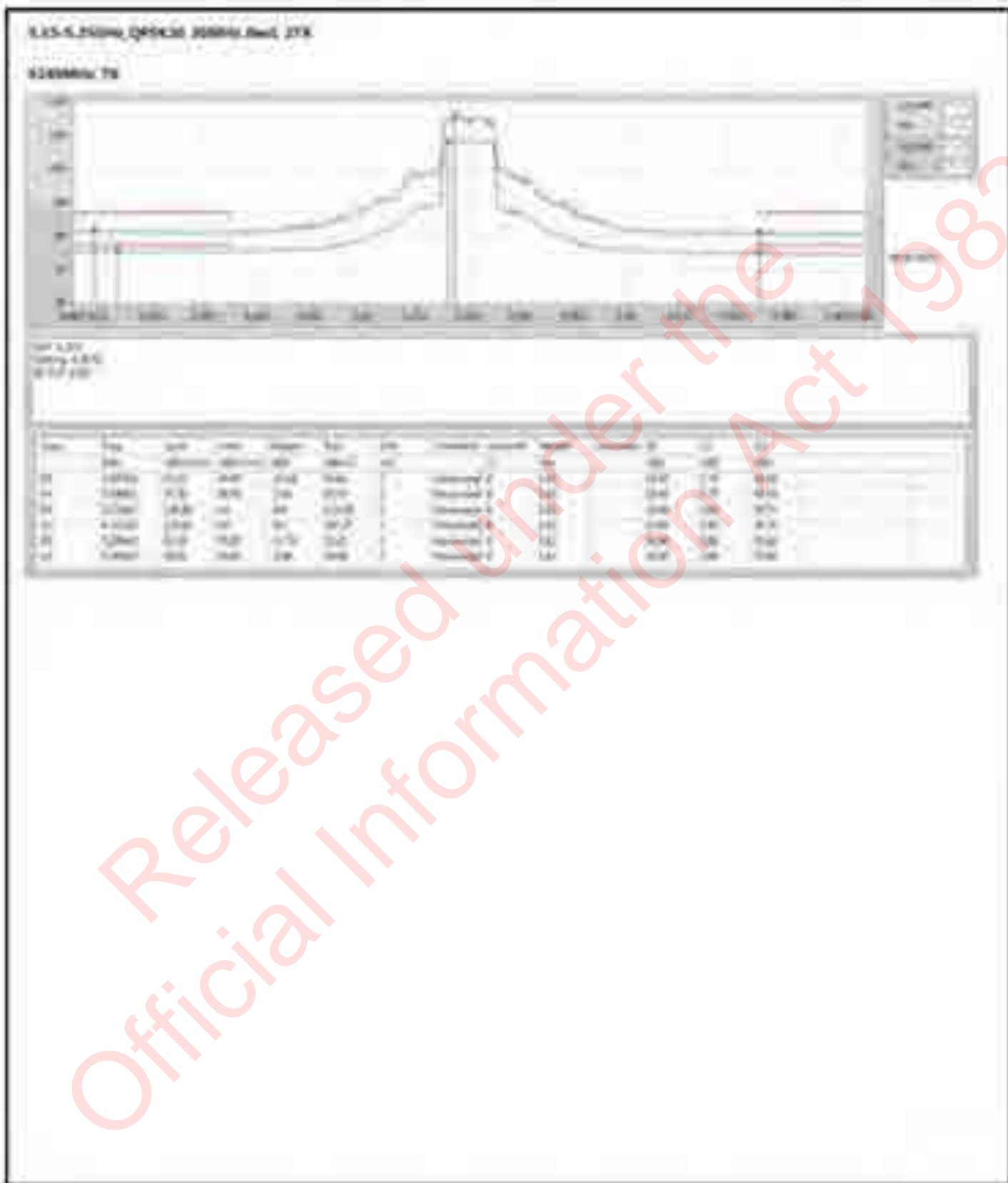

Released under the Official Information Act 1982



Released under the Official Information Act 1982



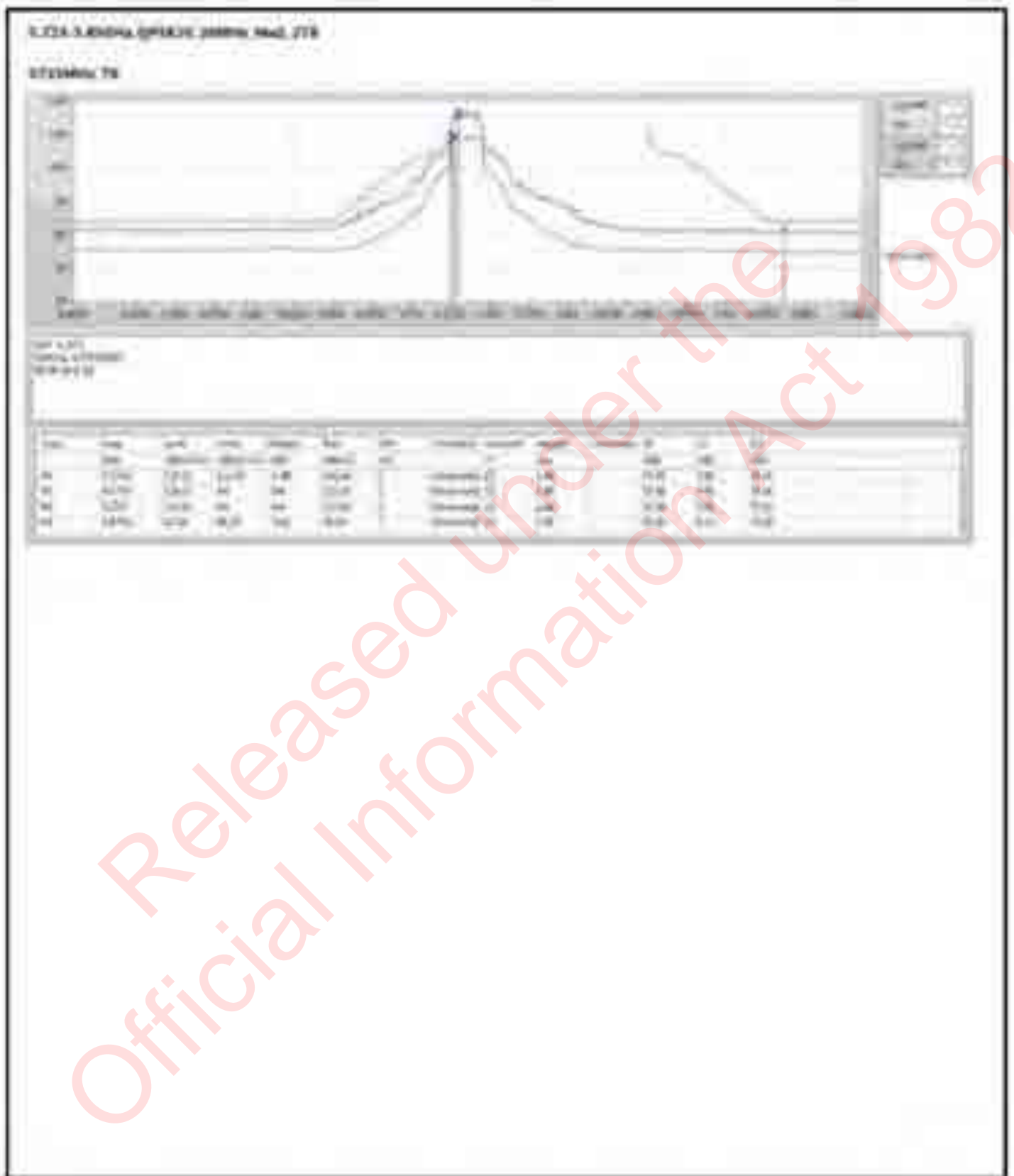





Released under the
Official Information Act 1982

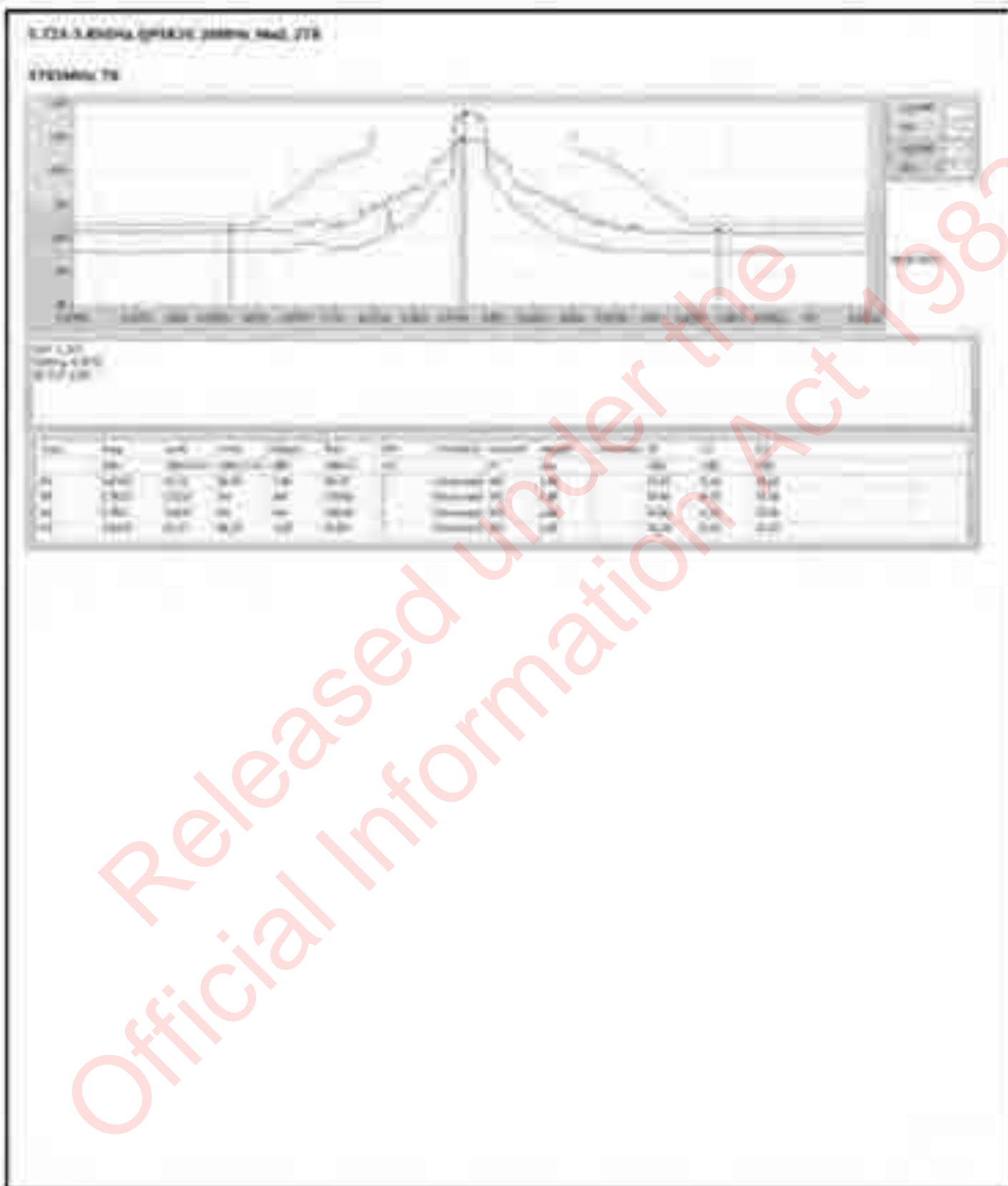





Released under the Official Information Act 1982

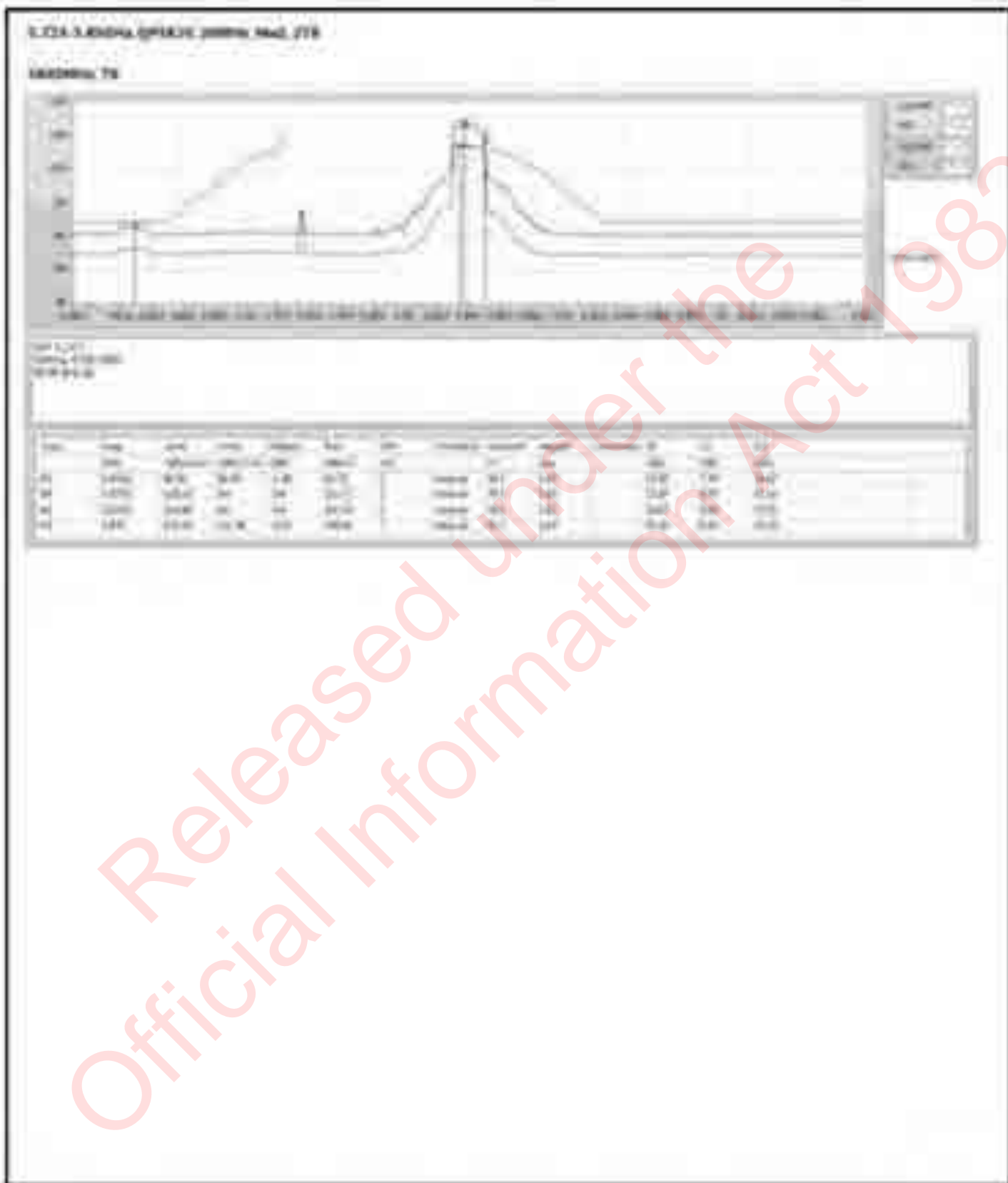

Released under the Official Information Act 1982

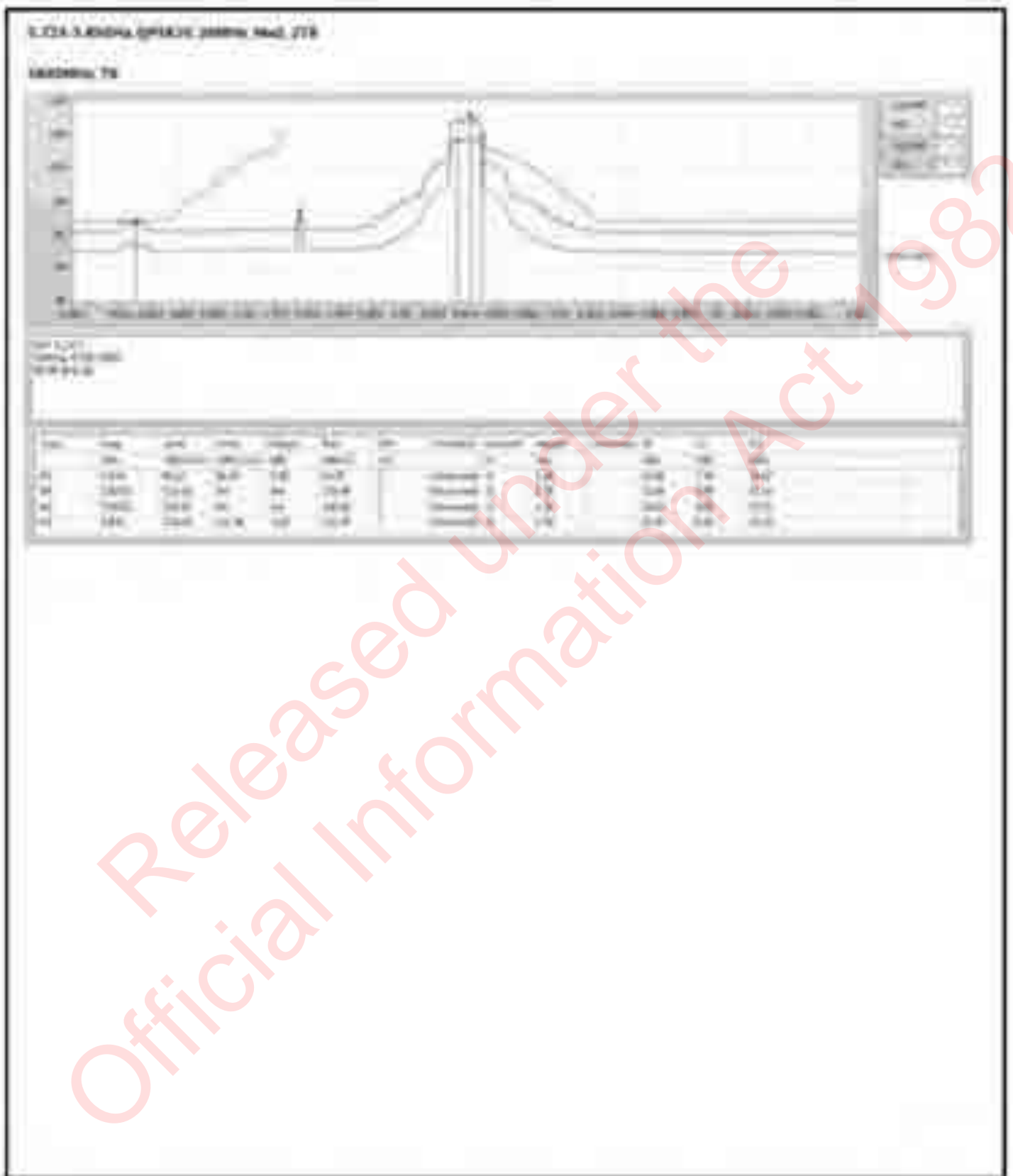





Released under the Official Information Act 1982



Released under the Official Information Act 1982

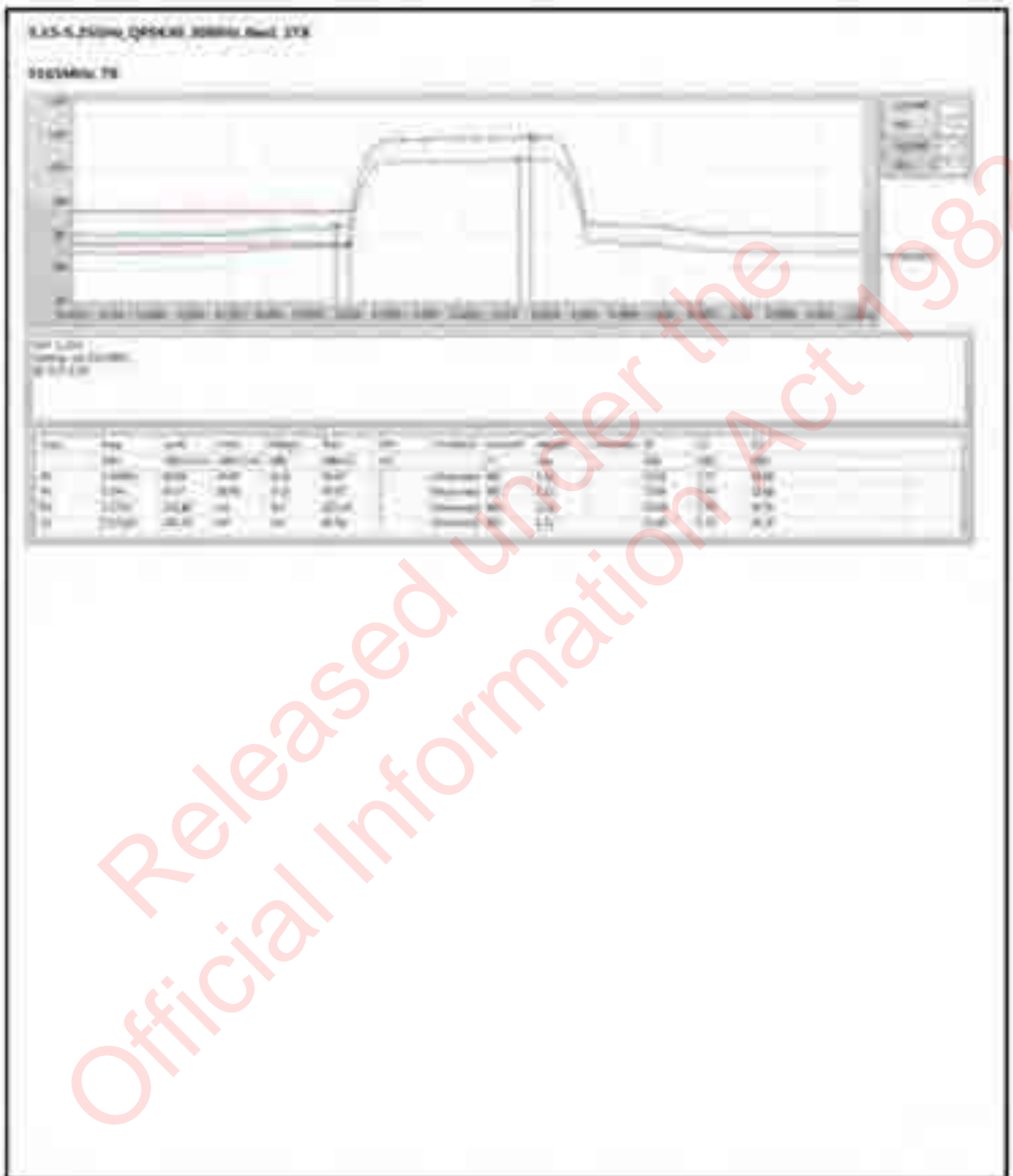

Released under the Official Information Act 1982







Released under the
Official Information Act 1982



Released under the Official Information Act 1982









Released under the Official Information Act 1982



Released under the Official Information Act 1982



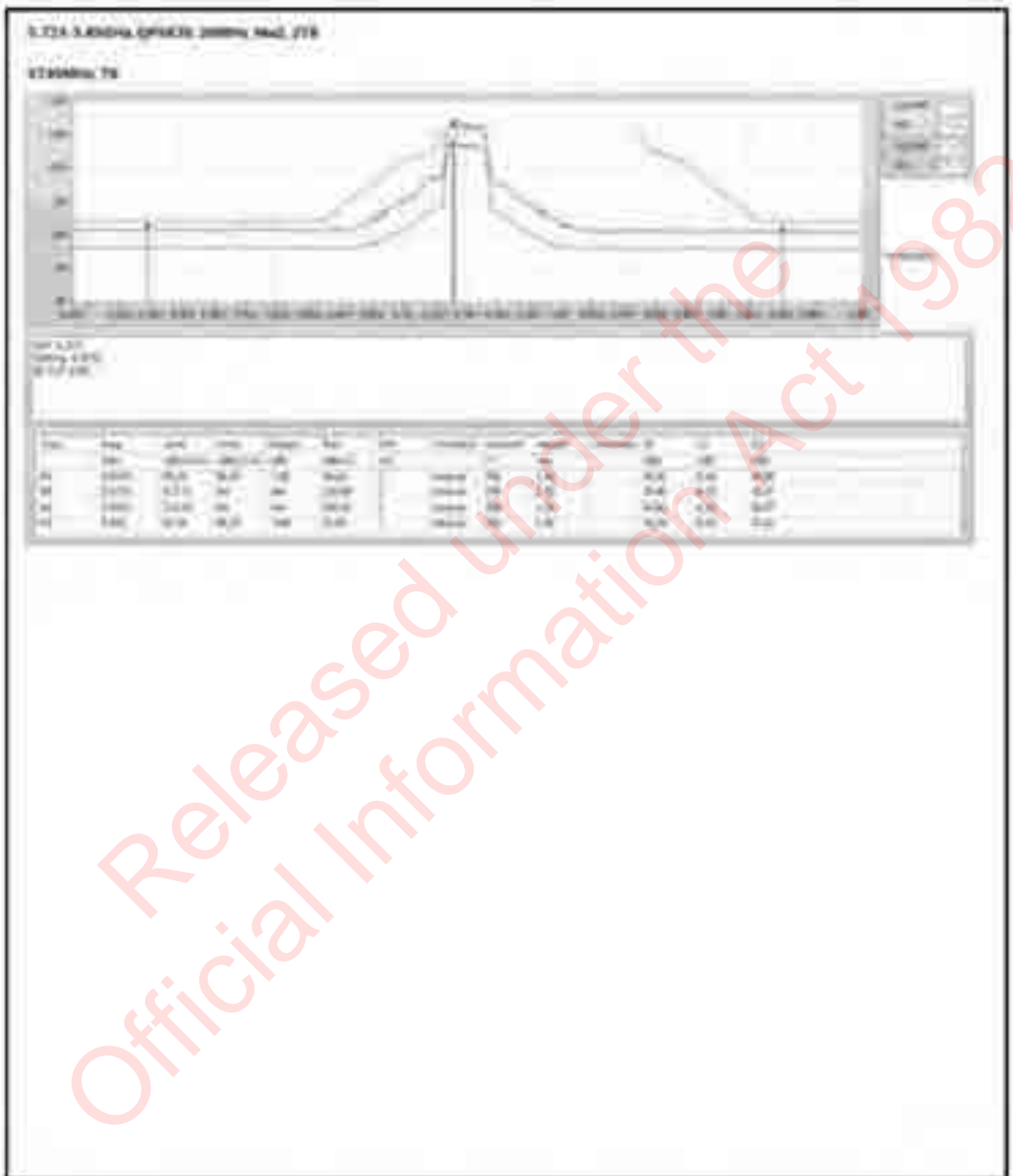

Released under the Official Information Act 1982



Released under the Official Information Act 1982



Released under the
Official Information Act 1982



Released under the
Official Information Act 1982

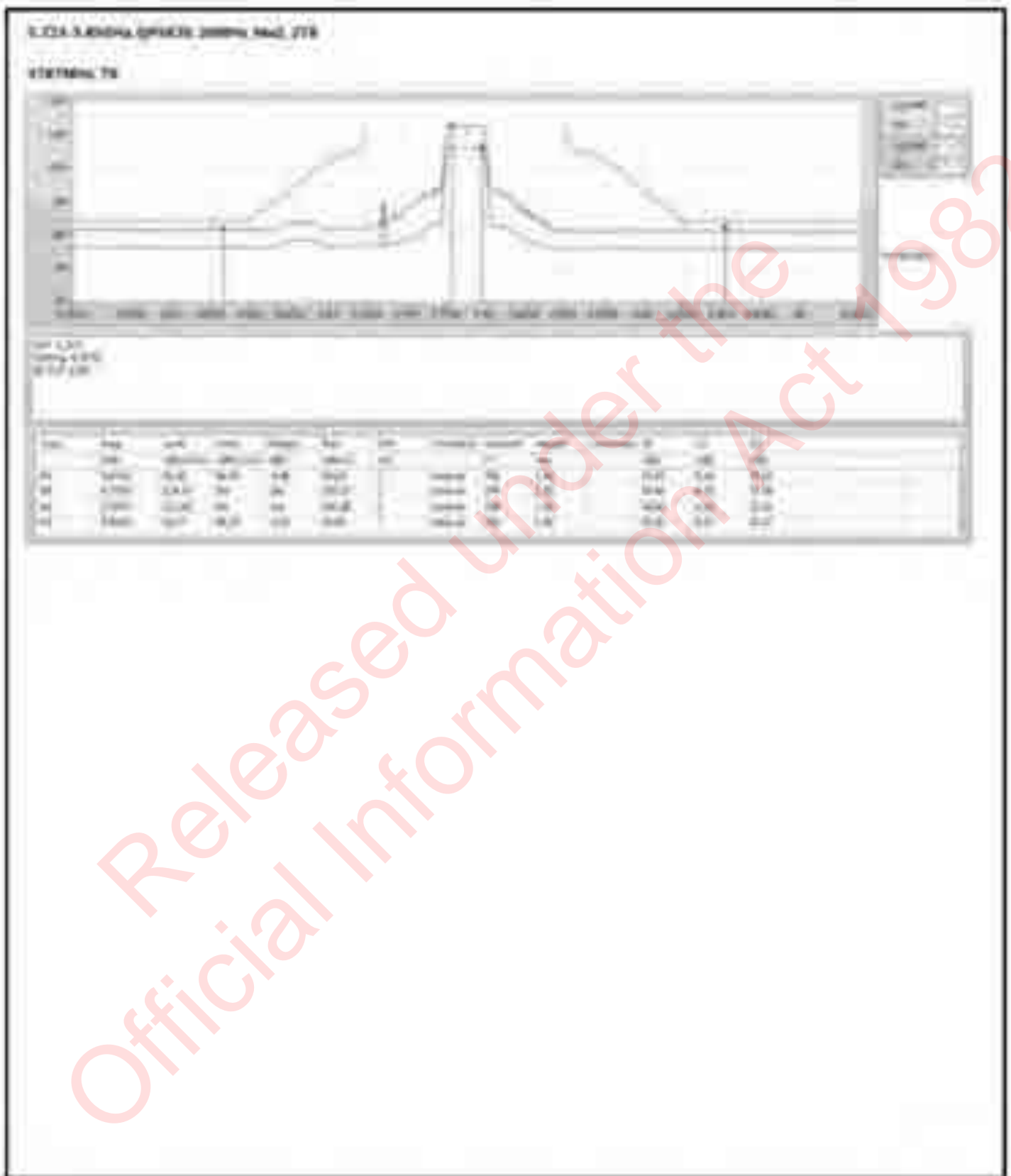



Released under the
Official Information Act 1982



Released under the Official Information Act 1982





Released under the
Official Information Act 1982



Released under the Official Information Act 1982



Released under the
Official Information Act 1982











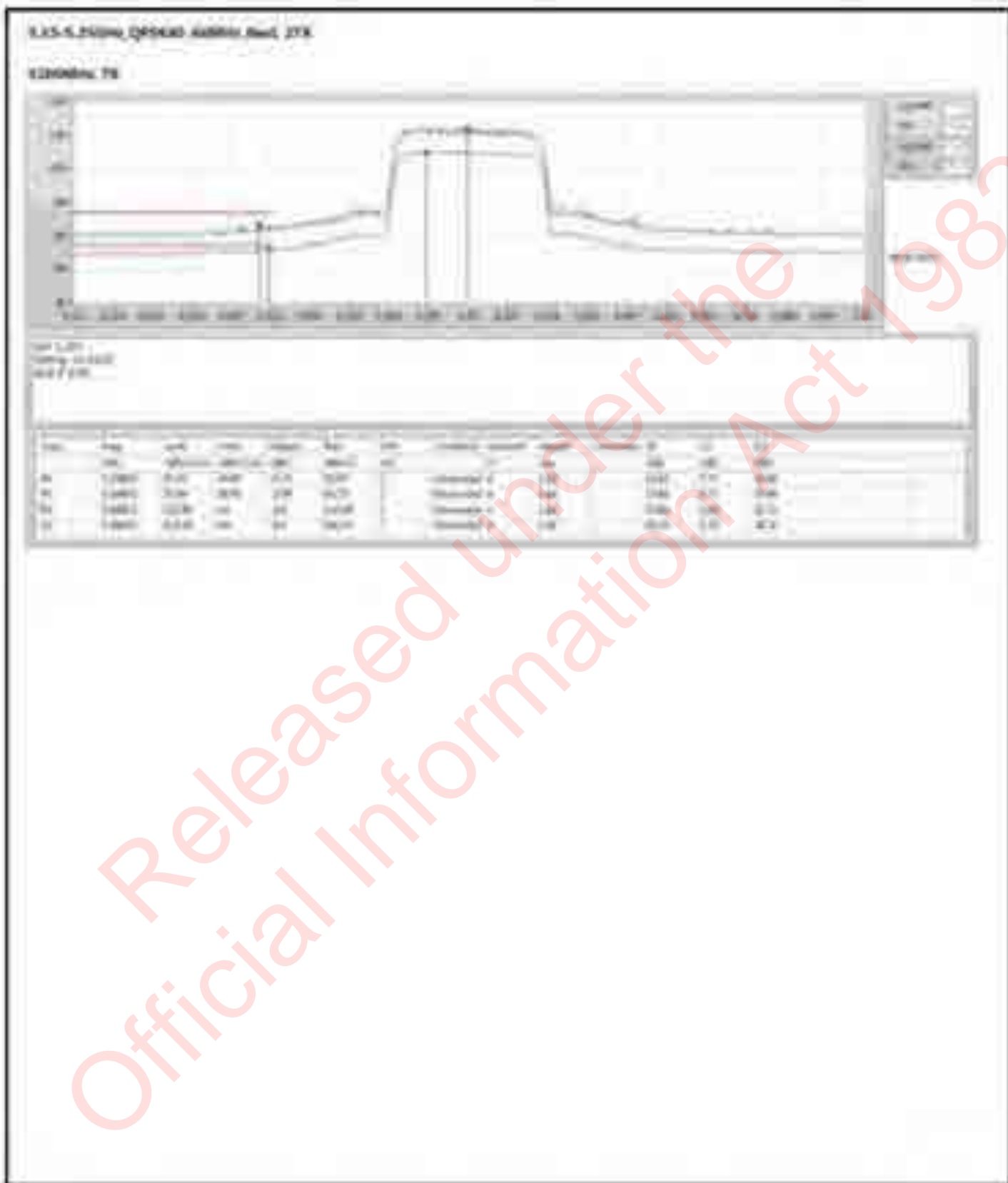

Released under the Official Information Act 1982





Released under the Official Information Act 1982



1.25-5.0GHz Other Test Mode

12/10/2016

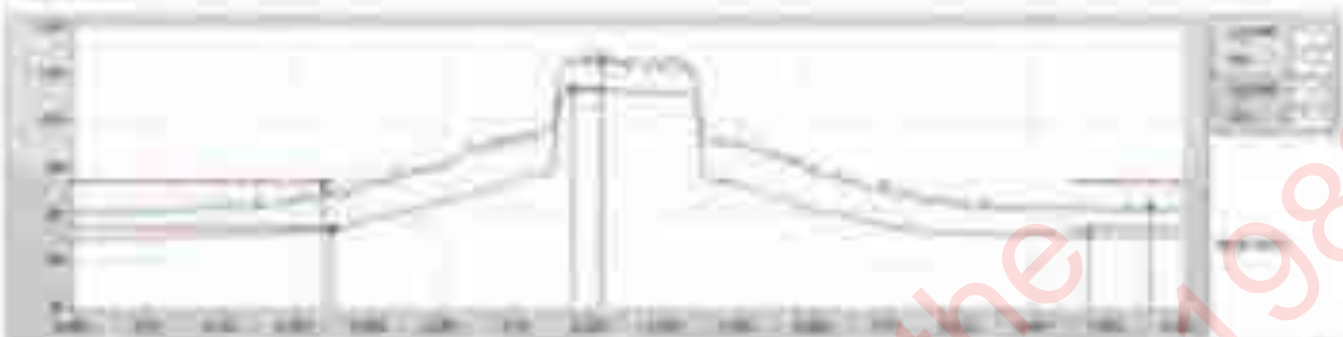

Ch	Freq	Power	Mod	Band	Usage	Priority	Channel Width	Guard	Offset	Remarks
1	1250.000	-100	None	12.5MHz	None	None	12.5MHz	None	None	
2	1300.000	-100	None	12.5MHz	None	None	12.5MHz	None	None	
3	1350.000	-100	None	12.5MHz	None	None	12.5MHz	None	None	
4	1400.000	-100	None	12.5MHz	None	None	12.5MHz	None	None	
5	1450.000	-100	None	12.5MHz	None	None	12.5MHz	None	None	
6	1500.000	-100	None	12.5MHz	None	None	12.5MHz	None	None	
7	1550.000	-100	None	12.5MHz	None	None	12.5MHz	None	None	
8	1600.000	-100	None	12.5MHz	None	None	12.5MHz	None	None	
9	1650.000	-100	None	12.5MHz	None	None	12.5MHz	None	None	
10	1700.000	-100	None	12.5MHz	None	None	12.5MHz	None	None	
11	1750.000	-100	None	12.5MHz	None	None	12.5MHz	None	None	
12	1800.000	-100	None	12.5MHz	None	None	12.5MHz	None	None	
13	1850.000	-100	None	12.5MHz	None	None	12.5MHz	None	None	
14	1900.000	-100	None	12.5MHz	None	None	12.5MHz	None	None	
15	1950.000	-100	None	12.5MHz	None	None	12.5MHz	None	None	
16	2000.000	-100	None	12.5MHz	None	None	12.5MHz	None	None	
17	2050.000	-100	None	12.5MHz	None	None	12.5MHz	None	None	
18	2100.000	-100	None	12.5MHz	None	None	12.5MHz	None	None	
19	2150.000	-100	None	12.5MHz	None	None	12.5MHz	None	None	
20	2200.000	-100	None	12.5MHz	None	None	12.5MHz	None	None	
21	2250.000	-100	None	12.5MHz	None	None	12.5MHz	None	None	
22	2300.000	-100	None	12.5MHz	None	None	12.5MHz	None	None	
23	2350.000	-100	None	12.5MHz	None	None	12.5MHz	None	None	
24	2400.000	-100	None	12.5MHz	None	None	12.5MHz	None	None	
25	2450.000	-100	None	12.5MHz	None	None	12.5MHz	None	None	
26	2500.000	-100	None	12.5MHz	None	None	12.5MHz	None	None	
27	2550.000	-100	None	12.5MHz	None	None	12.5MHz	None	None	
28	2600.000	-100	None	12.5MHz	None	None	12.5MHz	None	None	
29	2650.000	-100	None	12.5MHz	None	None	12.5MHz	None	None	
30	2700.000	-100	None	12.5MHz	None	None	12.5MHz	None	None	
31	2750.000	-100	None	12.5MHz	None	None	12.5MHz	None	None	
32	2800.000	-100	None	12.5MHz	None	None	12.5MHz	None	None	
33	2850.000	-100	None	12.5MHz	None	None	12.5MHz	None	None	
34	2900.000	-100	None	12.5MHz	None	None	12.5MHz	None	None	
35	2950.000	-100	None	12.5MHz	None	None	12.5MHz	None	None	
36	3000.000	-100	None	12.5MHz	None	None	12.5MHz	None	None	
37	3050.000	-100	None	12.5MHz	None	None	12.5MHz	None	None	
38	3100.000	-100	None	12.5MHz	None	None	12.5MHz	None	None	
39	3150.000	-100	None	12.5MHz	None	None	12.5MHz	None	None	
40	3200.000	-100	None	12.5MHz	None	None	12.5MHz	None	None	
41	3250.000	-100	None	12.5MHz	None	None	12.5MHz	None	None	
42	3300.000	-100	None	12.5MHz	None	None	12.5MHz	None	None	
43	3350.000	-100	None	12.5MHz	None	None	12.5MHz	None	None	
44	3400.000	-100	None	12.5MHz	None	None	12.5MHz	None	None	
45	3450.000	-100	None	12.5MHz	None	None	12.5MHz	None	None	
46	3500.000	-100	None	12.5MHz	None	None	12.5MHz	None	None	
47	3550.000	-100	None	12.5MHz	None	None	12.5MHz	None	None	
48	3600.000	-100	None	12.5MHz	None	None	12.5MHz	None	None	
49	3650.000	-100	None	12.5MHz	None	None	12.5MHz	None	None	
50	3700.000	-100	None	12.5MHz	None	None	12.5MHz	None	None	
51	3750.000	-100	None	12.5MHz	None	None	12.5MHz	None	None	
52	3800.000	-100	None	12.5MHz	None	None	12.5MHz	None	None	
53	3850.000	-100	None	12.5MHz	None	None	12.5MHz	None	None	
54	3900.000	-100	None	12.5MHz	None	None	12.5MHz	None	None	
55	3950.000	-100	None	12.5MHz	None	None	12.5MHz	None	None	
56	4000.000	-100	None	12.5MHz	None	None	12.5MHz	None	None	
57	4050.000	-100	None	12.5MHz	None	None	12.5MHz	None	None	
58	4100.000	-100	None	12.5MHz	None	None	12.5MHz	None	None	
59	4150.000	-100	None	12.5MHz	None	None	12.5MHz	None	None	
60	4200.000	-100	None	12.5MHz	None	None	12.5MHz	None	None	
61	4250.000	-100	None	12.5MHz	None	None	12.5MHz	None	None	
62	4300.000	-100	None	12.5MHz	None	None	12.5MHz	None	None	
63	4350.000	-100	None	12.5MHz	None	None	12.5MHz	None	None	
64	4400.000	-100	None	12.5MHz	None	None	12.5MHz	None	None	
65	4450.000	-100	None	12.5MHz	None	None	12.5MHz	None	None	
66	4500.000	-100	None	12.5MHz	None	None	12.5MHz	None	None	
67	4550.000	-100	None	12.5MHz	None	None	12.5MHz	None	None	
68	4600.000	-100	None	12.5MHz	None	None	12.5MHz	None	None	
69	4650.000	-100	None	12.5MHz	None	None	12.5MHz	None	None	
70	4700.000	-100	None	12.5MHz	None	None	12.5MHz	None	None	
71	4750.000	-100	None	12.5MHz	None	None	12.5MHz	None	None	
72	4800.000	-100	None	12.5MHz	None	None	12.5MHz	None	None	
73	4850.000	-100	None	12.5MHz	None	None	12.5MHz	None	None	
74	4900.000	-100	None	12.5MHz	None	None	12.5MHz	None	None	
75	4950.000	-100	None	12.5MHz	None	None	12.5MHz	None	None	
76	5000.000	-100	None	12.5MHz	None	None	12.5MHz	None	None	

Released under the Official Information Act 1982





Released under the Official Information Act 1982



Released under the
Official Information Act 1982



5.1234.5.825MHz Offset (dB) 200MHz Max. 37dB

512XMMW 75



Test Type: Other Test Mode

Frequency (MHz)	Power (dBm)	Offset (MHz)	Offset (dB)	Power (dBm)	Power (dBm)
1200	37	0	0	37	37
1250	37	50	37	37	37
1300	37	100	37	37	37
1350	37	150	37	37	37
1400	37	200	37	37	37

Released under the Official Information Act 1982



Released under the Official Information Act 1982



Released under the Official Information Act 1982





Released under the Official Information Act 1982

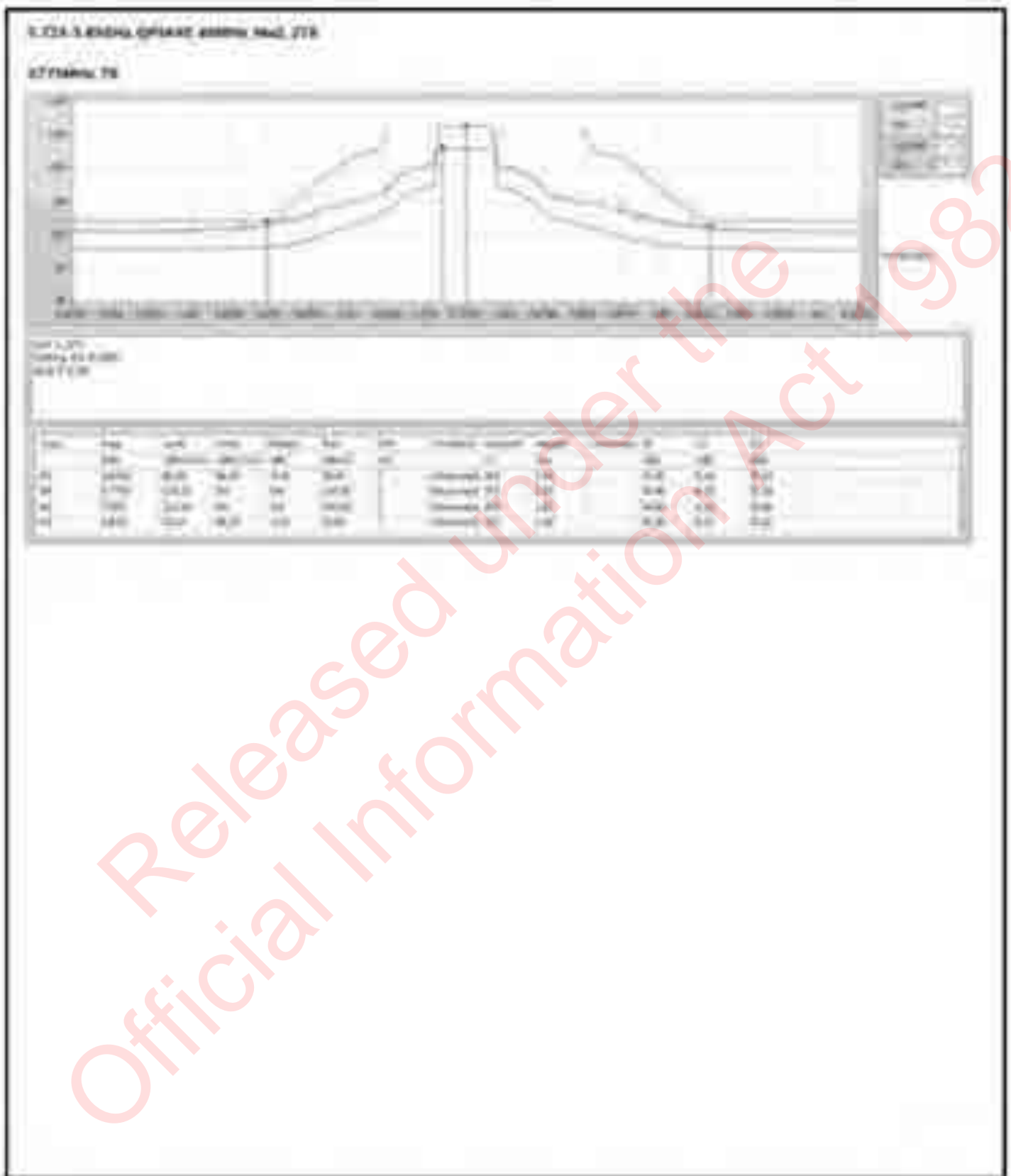



Released under the
Official Information Act 1982



Released under the
Official Information Act 1982





Released under the Official Information Act 1982





Released under the Official Information Act 1982



Summary

Mod	Mod	Type	Freq MHz	Level dBm/Hz	Level dBm/100Hz	Mask dB	Mod Mask	Carrier	Actual FT	Mask dB	Comment
TOTAL POWER											
1270.000000	1270.000000	Power	1270.000	12.70	-14.00	-1.00	0	1270.000000	1	-1.00	

Released under the
Official Information Act 1982



Released under the
Official Information Act 1982



Released under the Official Information Act 1982



Released under the Official Information Act 1982



Released under the Official Information Act 1982



Released under the
Official Information Act 1982



Released under the Official Information Act 1982



Released under the
Official Information Act 1982



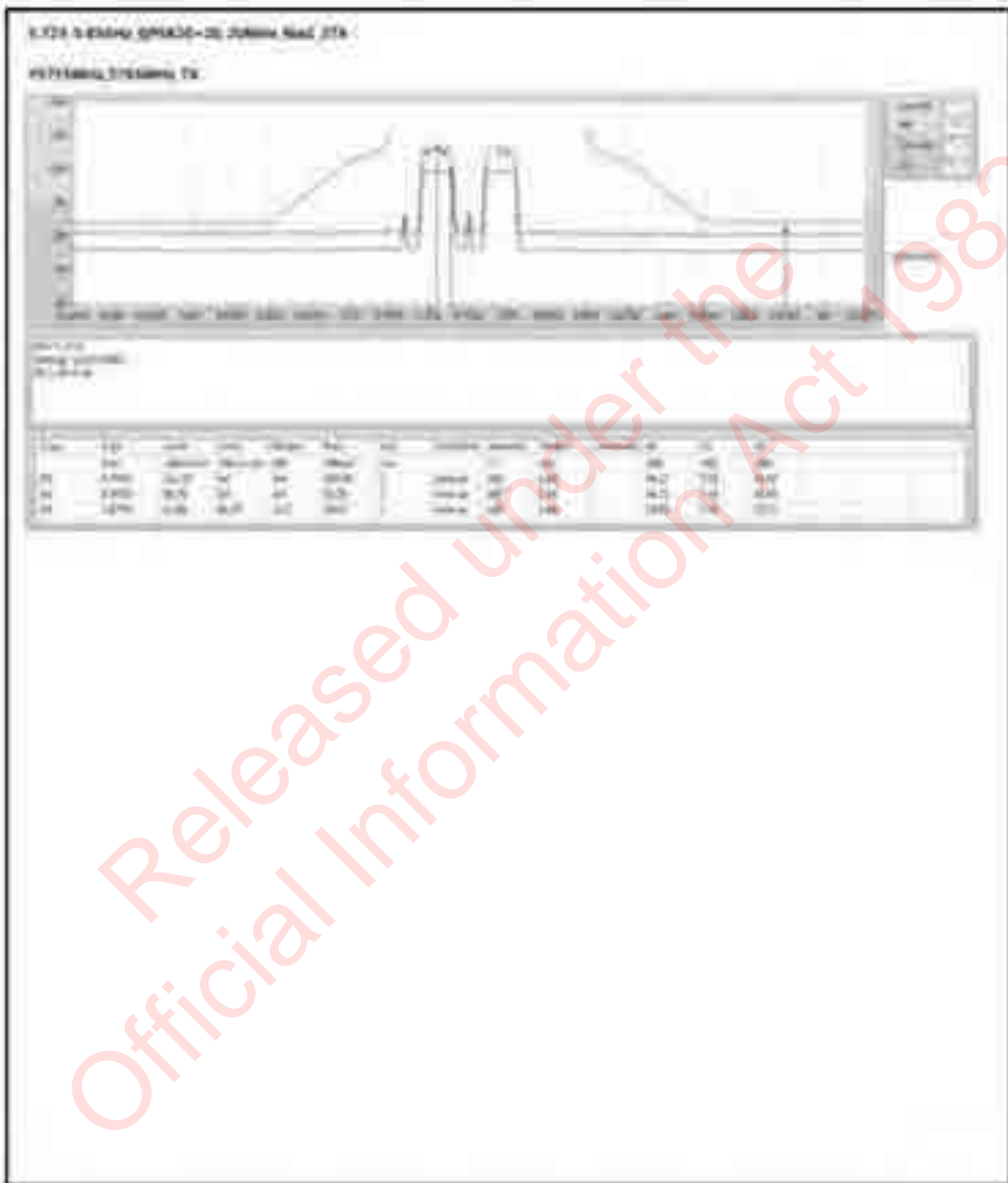

Released under the
Official Information Act 1982



Released under the
Official Information Act 1982

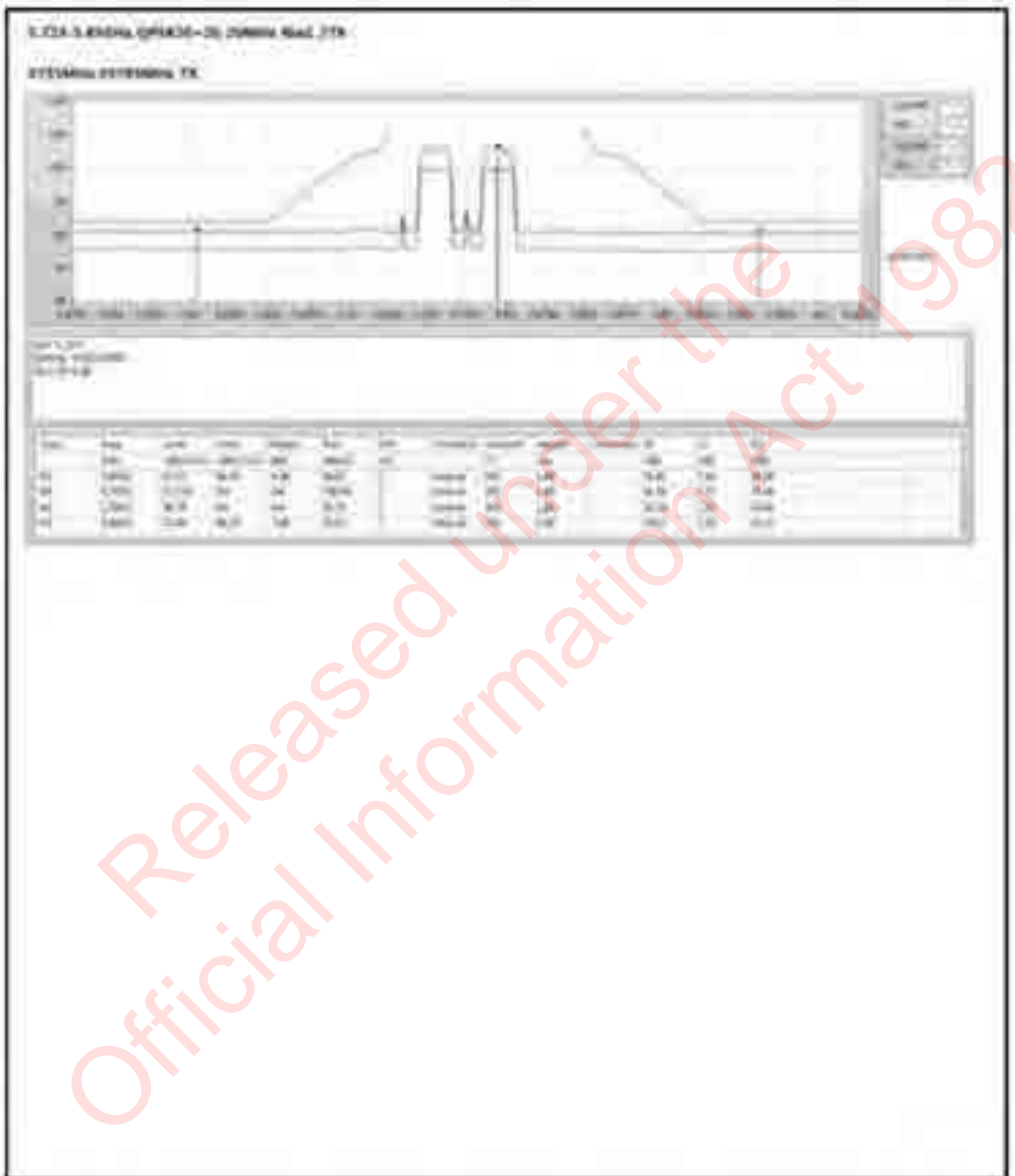

Released under the
Official Information Act 1982

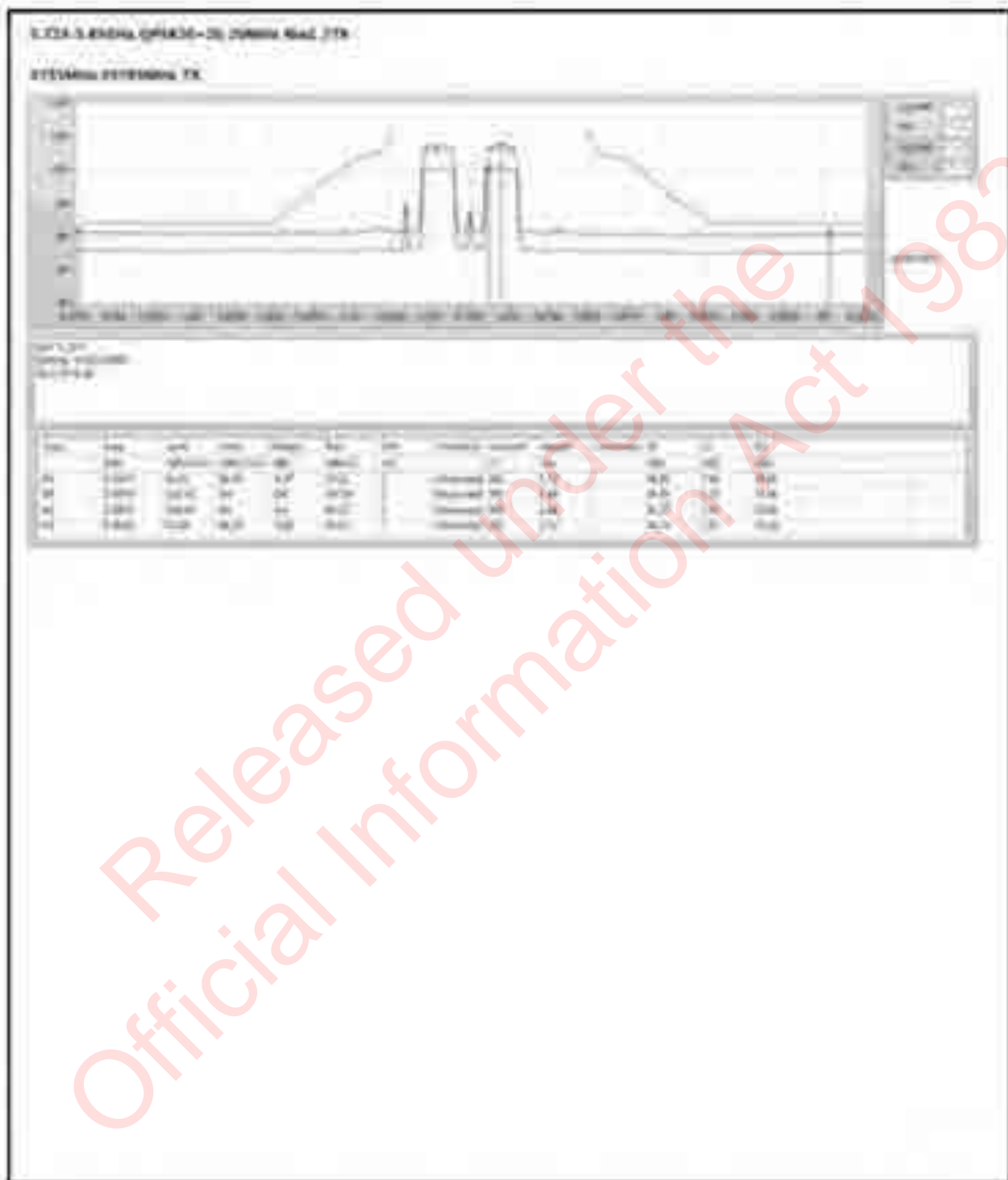

Released under the
Official Information Act 1982



Released under the Official Information Act 1982





Released under the
Official Information Act 1982



Released under the Official Information Act 1982



Released under the
Official Information Act 1982



Released under the
Official Information Act 1982



Released under the Official Information Act 1982



Released under the
Official Information Act 1982



Released under the
Official Information Act 1982



Released under the
Official Information Act 1982



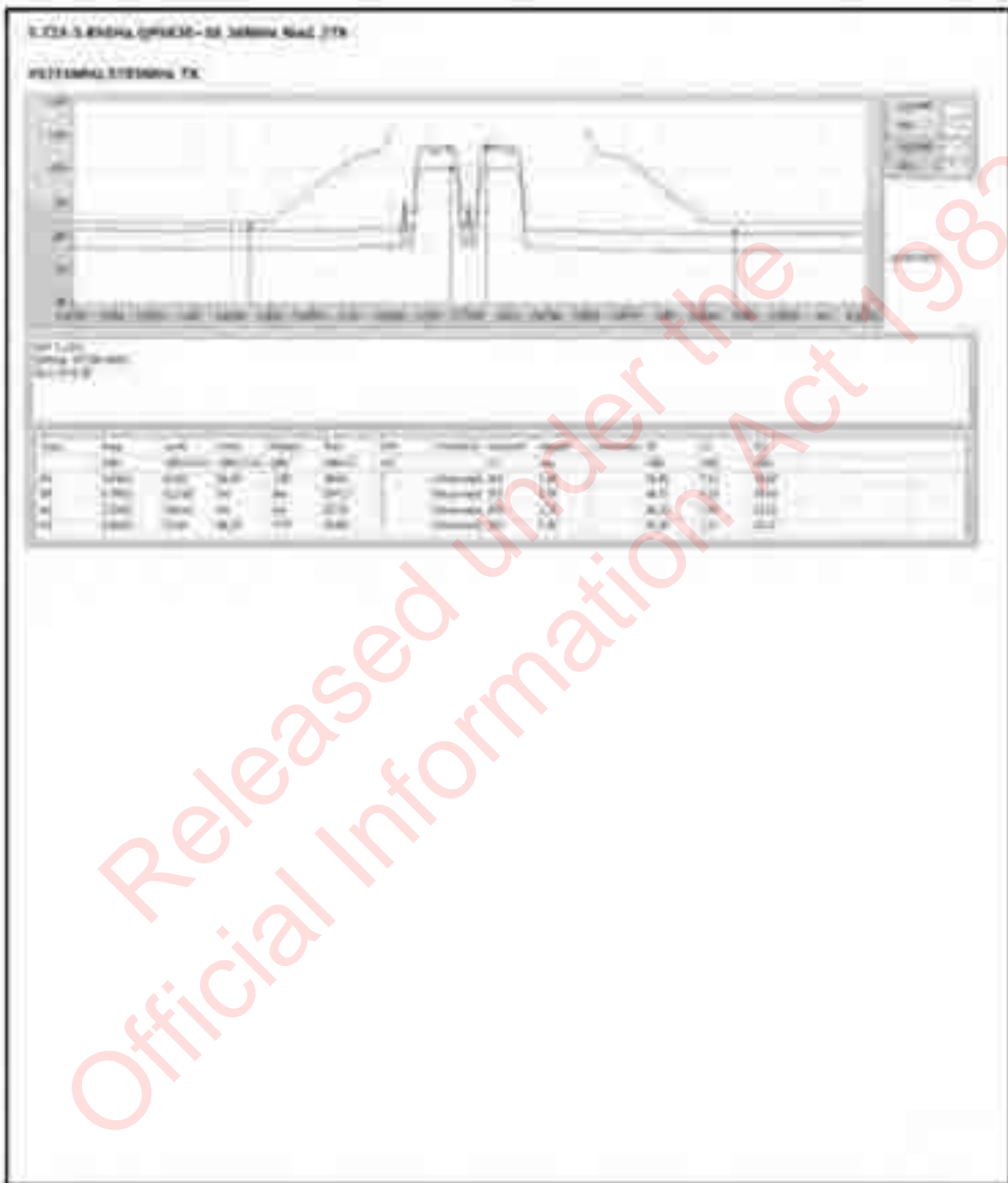



Released under the
Official Information Act 1982



Released under the
Official Information Act 1982



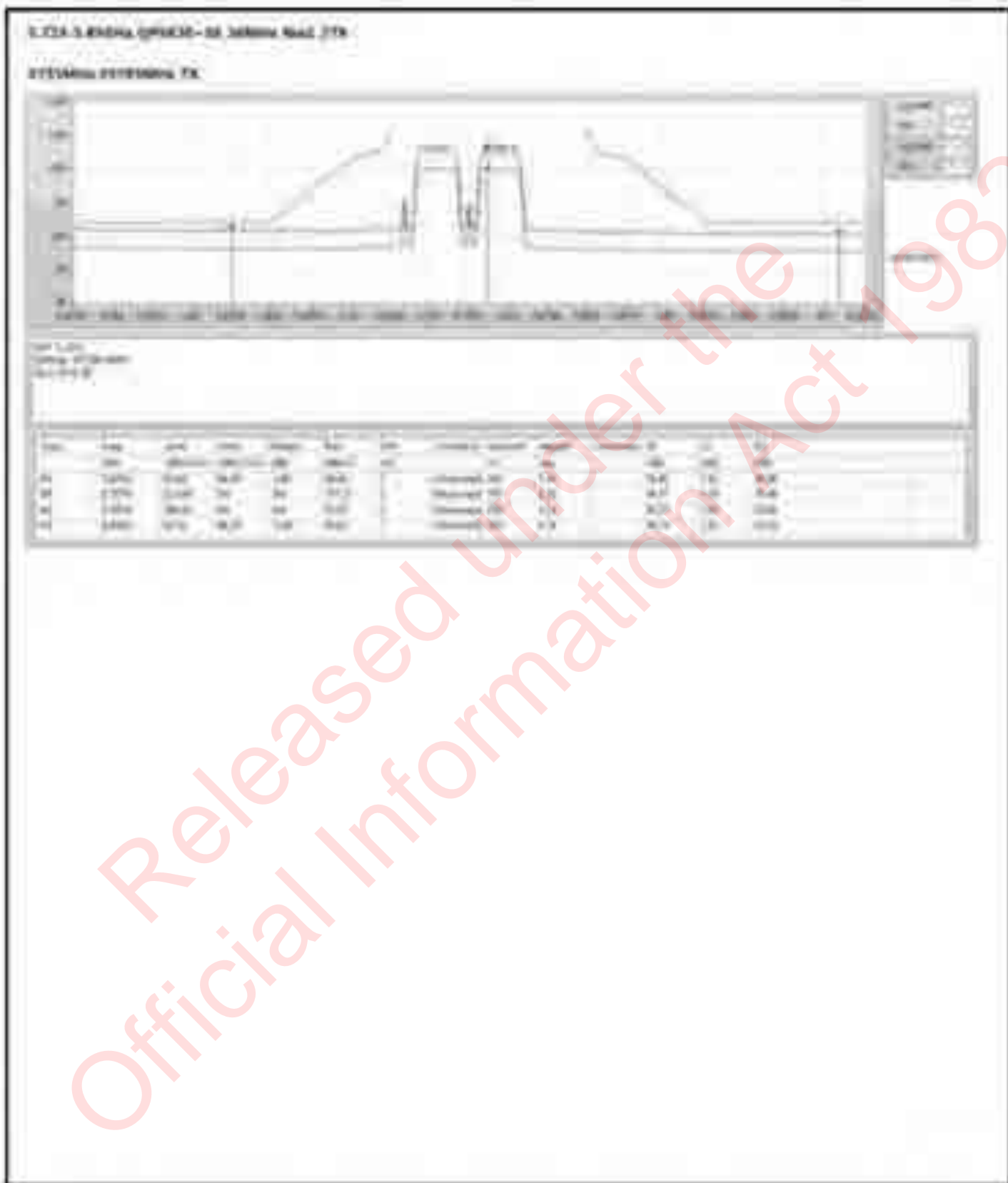



Released under the
Official Information Act 1982



Released under the
Official Information Act 1982



Released under the Official Information Act 1982



Released under the Official Information Act 1982



Released under the
Official Information Act 1982



Released under the
Official Information Act 1982



Released under the Official Information Act 1982



Released under the Official Information Act 1982







Released under the
Official Information Act 1982

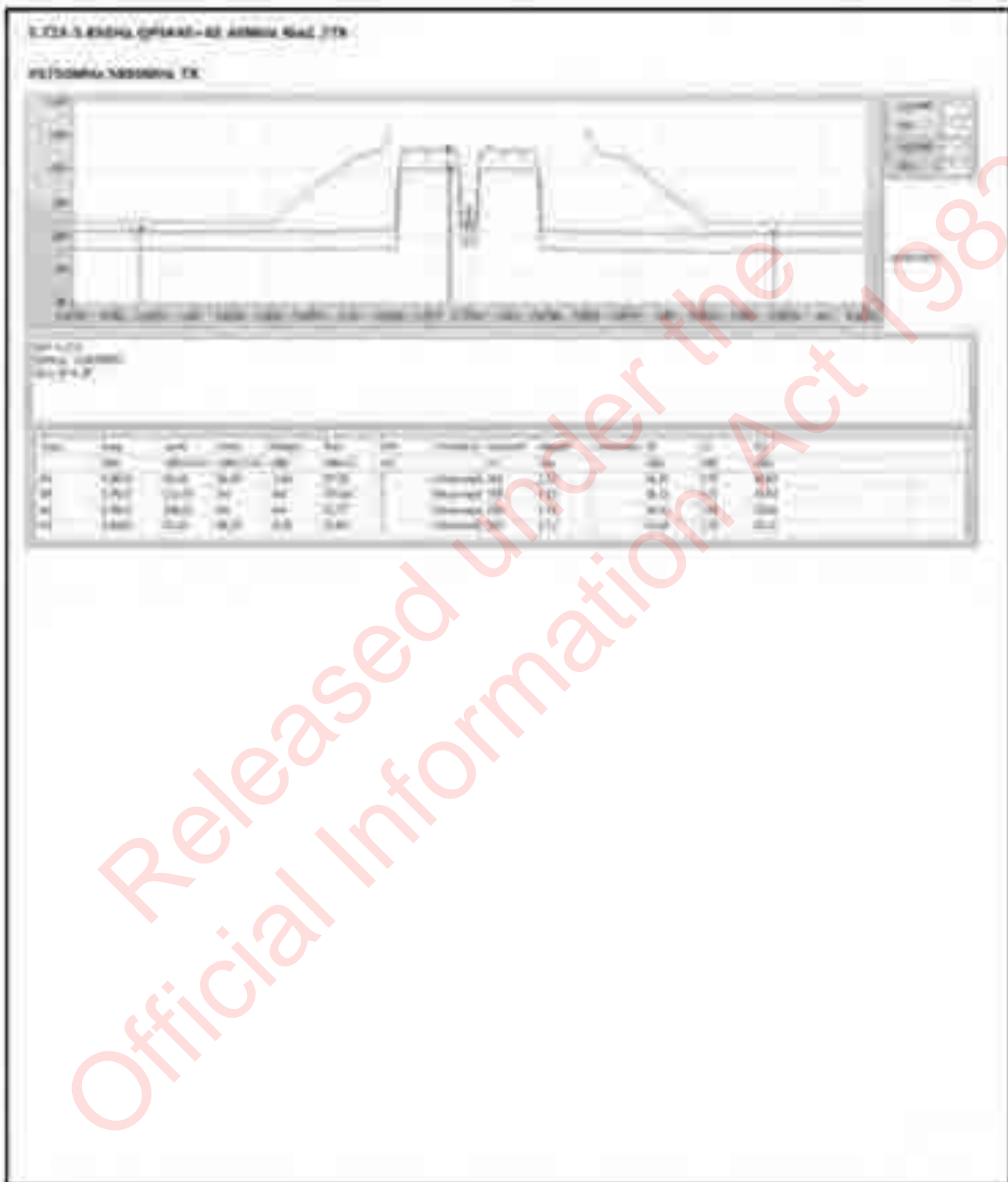

Released under the Official Information Act 1982





Released under the
Official Information Act 1982



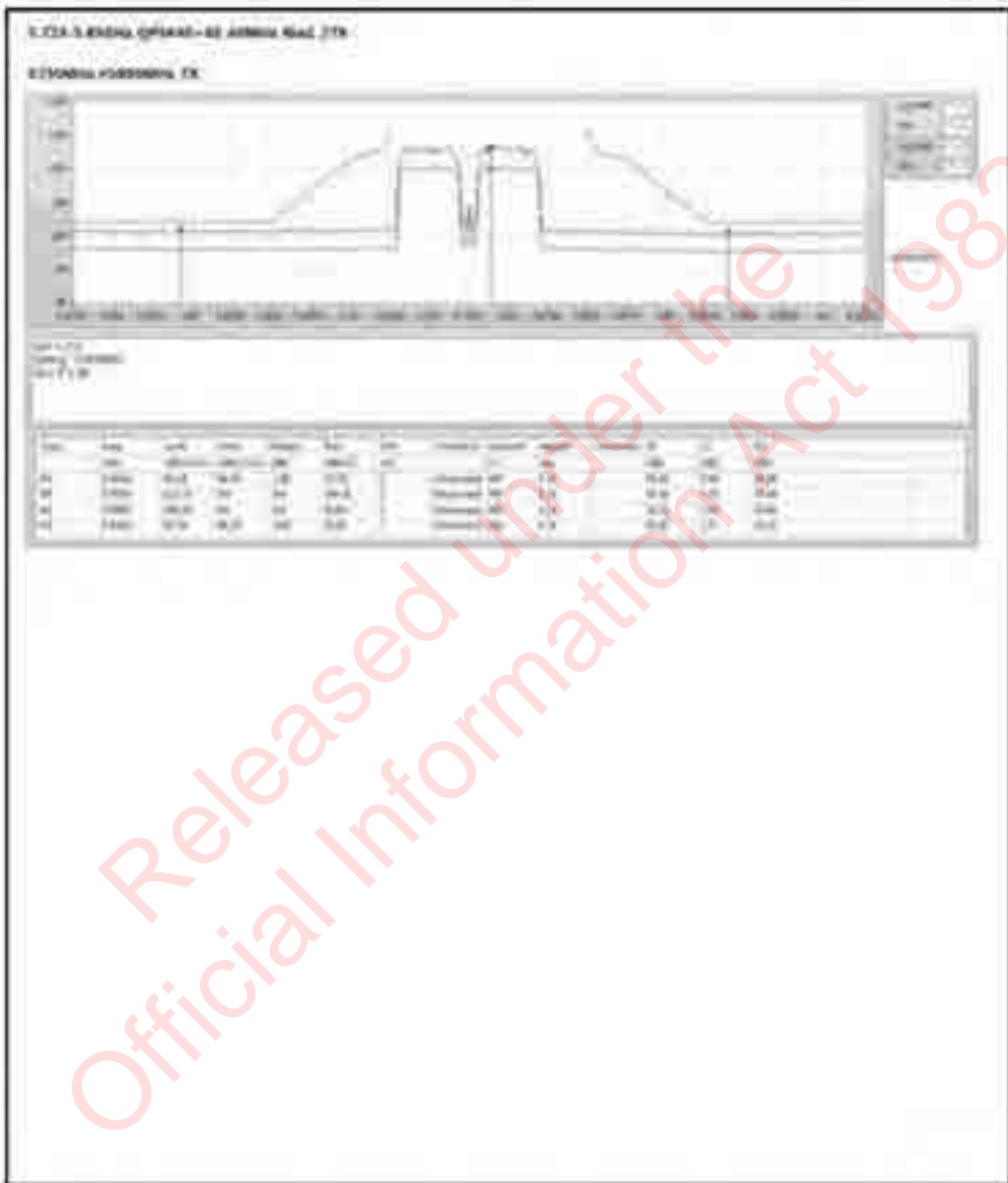

Released under the Official Information Act 1982





Released under the
Official Information Act 1982



RADIO TEST REPORT

FCC ID : Z8H89FT0081
Equipment : 6084HH
Brand Name : Cambium Networks
Model Name : 6084HH
Applicant : Cambium Networks Inc.
3800 Golf Road, Suite 360 Rolling Meadows, IL 60008, USA
Manufacturer : Cambium Networks, Ltd.
Ashburton, TQ13 7UP, UK
Standard : 47 CFR FCC Part 15.407

The product was received on Oct. 17, 2023, and testing was started from Oct. 17, 2023 and completed on Apr. 17, 2024. We, Sporton International Inc. Hsinchu Laboratory, would like to declare that the tested sample has been evaluated in accordance with the procedures given in ANSI C63.10-2013 and shown compliance with the applicable technical standards.

The test results in this variant report apply exclusively to the tested model / sample. Without written approval of Sporton International Inc. Hsinchu Laboratory, the test report shall not be reproduced except in full.



Approved by: Sam Chen

Sporton International Inc. Hsinchu Laboratory

No.8, Ln. 724, Bo'ai St., Zhubei City, Hsinchu County 302010, Taiwan (R.O.C.)



Table of Contents

History of this test report	3
Summary of Test Result	4
1 General Description	5
1.1 Information.....	5
1.2 Applicable Standards	10
1.3 Testing Location Information	10
1.4 Measurement Uncertainty	11
2 Test Configuration of EUT	12
2.1 Test Channel Mode	12
2.2 The Worst Case Measurement Configuration	13
2.3 EUT Operation during Test	13
2.4 Accessories	13
2.5 Support Equipment.....	14
2.6 Test Setup Diagram	15
3 Transmitter Test Result	18
3.1 AC Power-line Conducted Emissions	18
3.2 Emission Bandwidth	20
3.3 Maximum Equivalent Isotropically Radiated Power (E.I.R.P.)	21
3.4 Peak Power Spectral Density (E.I.R.P.).....	23
3.5 Unwanted Emissions.....	26
4 Test Equipment and Calibration Data	31
Appendix A. Test Results of AC Power-line Conducted Emissions	
Appendix B. Test Results of Emission Bandwidth	
Appendix C. Test Results of Maximum Equivalent Isotropically Radiated Power (E.I.R.P.)	
Appendix D. Test Results of Peak Power Spectral Density (E.I.R.P.)	
Appendix E. Test Results of Unwanted Emissions	
Appendix F. Test Photos	
Photographs of EUT v01	

**Summary of Test Result**

Report Clause	Ref Std. Clause	Test Items	Result (PASS/FAIL)	Remark
1.1.2	15.203	Antenna Requirement	PASS	-
3.1	15.207	AC Power-line Conducted Emissions	PASS	-
3.2	15.407(a)	Emission Bandwidth	PASS	-
3.3	15.407(a)	Maximum Equivalent Isotropically Radiated Power (EIRP)	PASS	-
3.4	15.407(a)	Peak Power Spectral Density (EIRP)	PASS	-
3.5	15.407(b)	Unwanted Emissions	PASS	-
-	15.407(d)	Contention-Based Protocol	N/A	Standard Power AP no test.

Conformity Assessment Condition:

1. The test results (PASS/FAIL) with all measurement uncertainty excluded are presented against the regulation limits or in accordance with the requirements stipulated by the applicant manufacturer who shall bear all the risks of non-compliance that may potentially occur if measurement uncertainty is taken into account.
2. The measurement uncertainty please refer to each test result in the chapter "Measurement Uncertainty".

Disclaimer:

The product specifications of the EUT presented in the test report that may affect the test assessments are declared by the manufacturer who shall take full responsibility for the authenticity.

Reviewed by: Sam Chen
Report Producer: Cathy Chiu



1 General Description

1.1 Information

1.1.1 RF General Information

Frequency Range (MHz)	IEEE Std. 802.11	Ch. Frequency (MHz)	Ch. Space (MHz)
5025-6425	5	5928-6422	1
6525-6875		6528-6872	1
5025-6425	40	5945-6405	1
6525-6875		6545-6855	1

Band	Mode	BWch (MHz)	Wint
5.925-6.425GHz	QPSK	5	2TX
5.925-6.425GHz	QPSK40	40	2TX
6.525-6.875GHz	QPSK	5	2TX
6.525-6.875GHz	QPSK40	40	2TX

Note:

- The 8GHz function uses QPSK modulation.
- BWch is the nominal channel bandwidth.

Released under the Official Information Act 1982



1.1.2 Antenna Information

Ant.	Port					Brand	Model Name	Antenna Type	Connector	Gain (dBi)
	5GHz			6GHz						
	R1	R2	R1+R2	R1	R2					
1	-	1	3	-	1	Cambium	Canopy V 4X4 Array Antenna	Array	RP-SMA	Note 1
2	-	2	4	-	2	Cambium	Canopy V 4X4 Array Antenna	Array	RP-SMA	
3	2	-	2	2	-	Cambium	Canopy V 4X4 Array Antenna	Array	RP-SMA	
4	1	-	1	1	-	Cambium	Canopy V 4X4 Array Antenna	Array	RP-SMA	

Note 1:

Ant.	Port					Gain (dBi)	
	5GHz			6GHz		5GHz	6GHz
	R1	R2	R1+R2	R1	R2		
1	-	1	3	-	1	15.922	15.892
2	-	2	4	-	2	15.958	15.958
3	2	-	2	2	-	15.902	15.893
4	1	-	1	1	-	15.906	15.906

Note 2: The above information was declared by manufacturer.



Note 3: Directional gain information

Type	Maximum Output Power	Power Spectral Density
Non-BF	Directional gain = Max.gain + array gain. For power measurements on IEEE 802.11 devices Array Gain = 0 dB (i.e., no array gain) for N ANT ≤ 4	$Directional\ Gain = 10 \cdot \log \left[\frac{\sum_{k=1}^N \left(\sum_{l=1}^N P_{k,l} \right)^2}{P_{TOT}} \right]$
BF	$Directional\ Gain = 10 \cdot \log \left[\frac{\sum_{k=1}^N \left(\sum_{l=1}^N P_{k,l} \right)^2}{P_{TOT}} \right]$	$Directional\ Gain = 10 \cdot \log \left[\frac{\sum_{k=1}^N \left(\sum_{l=1}^N P_{k,l} \right)^2}{P_{TOT}} \right]$

Ex.

Directional Gain (NSS1) formula :

$$Directional\ Gain = 10 \cdot \log \left[\frac{\sum_{k=1}^N \left(\sum_{l=1}^N P_{k,l} \right)^2}{P_{TOT}} \right]$$

$$NSS1(g1,1) = 10^{01/20} ; NSS1(g1,2) = 10^{02/20} ; NSS1(g1,3) = 10^{03/20} ; NSS1(g1,4) = 10^{04/20}$$

$$g(k) = (NSS1(g1,1) + NSS1(g1,2) + NSS1(g1,3) + NSS1(g1,4))^2$$

$$DG = 10 \log[(NSS1(g1,1) + NSS1(g1,2) + NSS1(g1,3) + NSS1(g1,4))^2 / N_{ANT}/N_{SS}] \Rightarrow 10 \log[(10^{01/20} + 10^{02/20} + 10^{03/20} + 10^{04/20})^2 / N_{ANT}]$$

Where :

Cross-Polarized Antenna

5G UNII-1 G1 = 15.962 dBi; G2 = 15.906 dBi;

5G UNII-3 G1 = 15.922 dBi; G2 = 15.958 dBi;

5G UNII-1 DG = 15.962 dBi

5G UNII-3 DG = 15.958 dBi

6E UNII-5 G1 = 15.931 dBi; G2 = 15.906 dBi;

6E UNII-7 G1 = 15.892 dBi; G2 = 15.958 dBi;

6E UNII-5 DG = 15.906 dBi

6E UNII-7 DG = 15.958 dBi

For 5GHz function:

For Radio 1 (R1) (2TX/2RX):

Port 1~2 can be used as transmitting/receiving antenna.

Port 1~2 could transmit/receive simultaneously.

For Radio 2 (R2) (2TX/2RX):

Port 1~2 can be used as transmitting/receiving antenna.

Port 1~2 could transmit/receive simultaneously.

**For Radio 1 + Radio 2 (R1+R2) (2TX/2RX):**

Port 1~4 can be used as transmitting/receiving antenna

Port 1~4 could transmit/receive simultaneously.

For 6GHz function:**For Radio 1 (R1) (2TX/2RX):**

Port 1~2 can be used as transmitting/receiving antenna

Port 1~2 could transmit/receive simultaneously.

For Radio 2 (R2) (2TX/2RX):

Port 1~2 can be used as transmitting/receiving antenna

Port 1~2 could transmit/receive simultaneously.

1.1.3 Mode Test Duty Cycle

Mode	DC	DCF(dB)	T _{off}	VBW(Hz) ≥ 1/T
QPSK	0.003	0.3	2.333m	1k
QPSK60	0.017	6.88	2.00m	1k

Note:

- DC is Duty Cycle.
- DCF is Duty Cycle Factor.

1.1.4 EUT Operational Condition

EUT Power Type	From PoE		
Beamforming Function	<input type="checkbox"/> With beamforming	<input checked="" type="checkbox"/>	Without beamforming
Device Type	<input checked="" type="checkbox"/> Indoor Access Point	<input type="checkbox"/>	Subordinate
	<input checked="" type="checkbox"/> Indoor Client	<input checked="" type="checkbox"/>	Standard Power Access Point
	<input type="checkbox"/> Dual Client	<input type="checkbox"/>	Standard Client
	<input type="checkbox"/> Fixed Client	<input type="checkbox"/>	Very Low Power
Condition of EUT	<input type="checkbox"/> Indoor	<input checked="" type="checkbox"/>	Outdoor
Test Software Version	DOS [ver 6.1.760j]		

Note: The above information was declared by manufacturer.

1.1.5 Table for Radio Function

Radio (R)	Function
R1	Support 5GHz UNII 1 and 6GHz UNII 5
R2	Support 5GHz UNII 3 and 6GHz UNII 7

Note: The above information was declared by manufacturer.

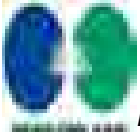

1.1.6 Table for Permissive Change

This product is an extension of original one reported under Sporton project number: FR380235

Below is the table for the change of the product with respect to the original one.

Modifications	Performance Checking
Add the Standard Power Access Point for 5MHz and 40MHz in UNII-5, UNII-7 through SW change.	All test items

Released under the Official Information Act 1982



1.2 Applicable Standards

According to the specifications of the manufacturer, the EUT must comply with the requirements of the following standards:

- ◆ 47 CFR FCC Part 15.407
- ◆ ANSI C63.10-2013
- ◆ FCC KDB 789033 D02 v02r01

The following reference test guidance is not within the scope of accreditation of TAF.

- ◆ FCC KDB 987594 D02 v02r01
- ◆ FCC KDB 662911 D01 v02r01
- ◆ FCC KDB 412172 D01 v01r01
- ◆ FCC KDB 414788 D01 v01r01

1.3 Testing Location Information

Testing Location Information	
Test Lab. : Sporton International Inc. Hsinchu Laboratory	
Hsinchu	ADD: No.8, Ln. 724, Bo'ai St., Zhubei City, Hsinchu County 302010, Taiwan (R.O.C.)
(TAF: 3787)	TEL: 886-3-656-9065 FAX: 886-3-656-9085
Test site Designation No. TW3787 with FCC.	
Conformity Assessment Body Identifier (CABID) TW3787 with ISED.	

Test Condition	Test Site No.	Test Engineer	Test Environment (°C / %)	Test Date
RF Conducted (Other tests)	TH03-CB	Owen Hsu	21.4~22.2 / 65~72	Nov. 16, 2023~ Nov. 20, 2023
RF Conducted (E.I.R.P. Power/PSD)	TH03-CB	Owen Hsu	21.4~22.2 / 65~72	Apr. 17, 2024
Radiated (Above 1GHz)	03CH03-CB	Black Lu	22-23 / 55-58	Oct. 17, 2023~ Oct. 18, 2023
Radiated (Below 1GHz)	10CH01-CB	Gray Lee	22~23 / 52~53	Jan. 16, 2024
AC Conduction	CO02-CB	Gray Lee	22~23 / 55~56	Dec. 20, 2023

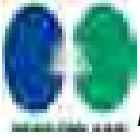

1.4 Measurement Uncertainty

ISO/IEC 17025 requires that an estimate of the measurement uncertainties associated with the emissions test results be included in the report. The measurement uncertainties given below are based on a 95% confidence level (based on a coverage factor (k=2))

Test Items	Uncertainty	Remark
Conducted Emission (150kHz ~ 30MHz)	3.4 dB	Confidence levels of 95%
Radiated Emission (9kHz ~ 30MHz)	3.7 dB	Confidence levels of 95%
Radiated Emission (30MHz ~ 1,000MHz)	5.1 dB	Confidence levels of 95%
Radiated Emission (1GHz ~ 18GHz)	4.1 dB	Confidence levels of 95%
Radiated Emission (18GHz ~ 40GHz)	4.2 dB	Confidence levels of 95%
Conducted Emission	3.1 dB	Confidence levels of 95%
Output Power Measurement	0.8 dB	Confidence levels of 95%
Power Density Measurement	3.1 dB	Confidence levels of 95%
Bandwidth Measurement	2.2%	Confidence levels of 95%

Released under FR380235-01
Official Information

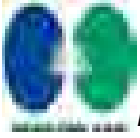

2 Test Configuration of EUT

2.1 Test Channel Mode

Mode
QPSK5_5MHz_Nss1_2TX
5928MHz
6175MHz
6422MHz
6528MHz
6700MHz
6872MHz
QPSK40_40MHz_Nss1_2TX
5945MHz
6175MHz
6405MHz
6545MHz
6700MHz
6855MHz Straddle 6.525-6.875GHz

Released under the
Official Information Act 1982



2.2 The Worst Case Measurement Configuration

The Worst Case Mode for Following Conformance Tests	
Tests Item	AC power-line conducted emissions
Condition	AC power-line conducted measurement for line and neutral Test Voltage: 120Vac / 60Hz
Operating Mode	CTX
1	EUT + PoE

The Worst Case Mode for Following Conformance Tests	
Tests Item	Emission Bandwidth Maximum Equivalent Isotropically Radiated Power (E.I.R.P.) Maximum E.I.R.P. at any elevation angle above 30 degrees Peak Power Spectral Density (E.I.R.P.)
Test Condition	Conducted measurement at transmit chains

The Worst Case Mode for Following Conformance Tests	
Tests Item	Unwanted Emissions
Test Condition	Radiated measurement If EUT consist of multiple antenna assembly (multiple antenna are used in EUT regardless of spatial multiplexing MIMO configuration), the radiated test should be performed with highest antenna gain of each antenna type.
Operating Mode	CTX
After evaluating, the worst case was found at Y axis, thus the measurement will follow this same test configuration.	
1	EUT in Y axis + PoE

The Worst Case Mode for Following Conformance Tests	
Tests Item	Emission MASK
Test Condition	Conducted measurement at transmit chains

Note: The PoE was for measurement only and would not be marketed. Its information is shown as below:

Power	Brand Name	Model Name
PoE	Cambium Networks	NET-P60-56IN

2.3 EUT Operation during Test

The EUT was programmed to be in continuously transmitting mode.

2.4 Accessories

Wall bracket*1

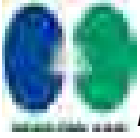

2.5 Support Equipment

For AC Conduction and Radiated (below 1GHz):

Support Equipment				
No.	Equipment	Brand Name	Model Name	FCC ID
A	PoE	Cambium Networks	NET-P60-56IN	N/A
B	LAN NB	DELL	E6430	N/A

For RF Conducted and Radiated (above 1GHz):

Support Equipment				
No.	Equipment	Brand Name	Model Name	FCC ID
A	NB	DELL	E4300	N/A
B	PoE	Cambium Networks	NET-P60-56IN	N/A

Released under the Official Information Act 1982



2.6 Test Setup Diagram

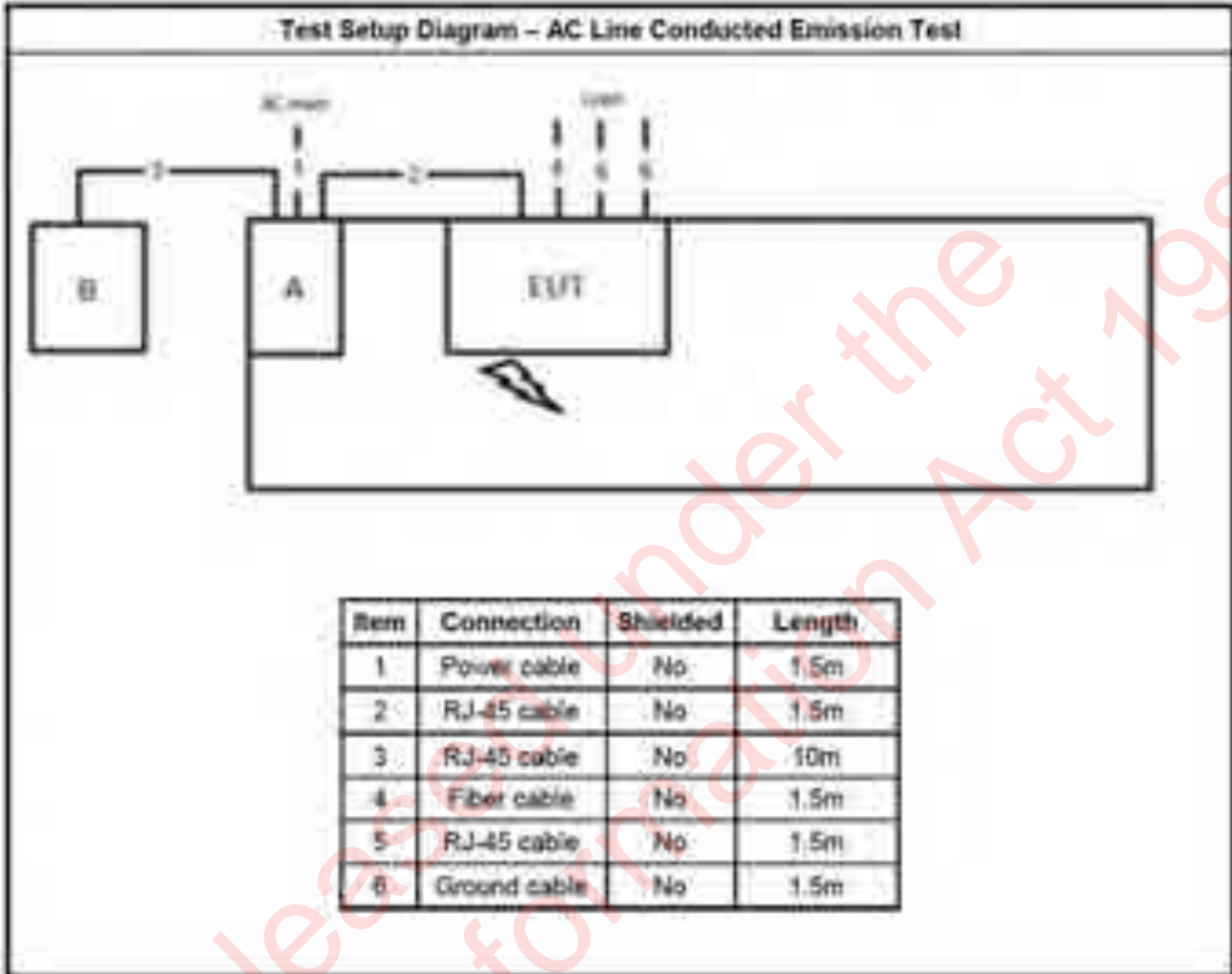

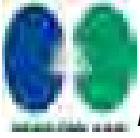

Test Setup Diagram - Radiated Test < 1GHz

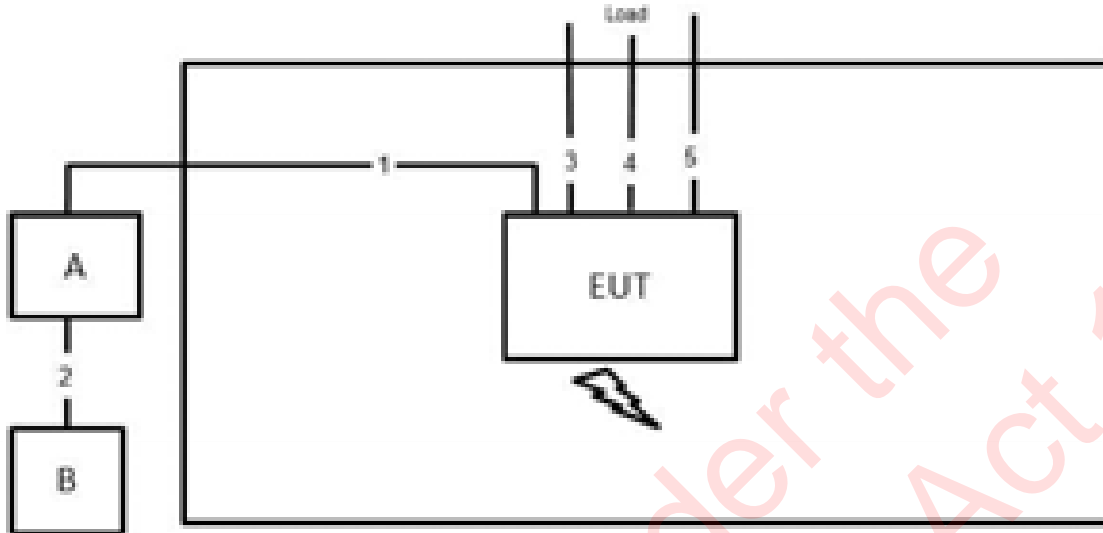

Item	Connection	Shielded	Length
1	RJ-45 cable	No	10m
2	RJ-45 cable	No	1.5m
3	Fiber cable	No	1m
4	RJ-45 cable	No	1.5m
5	Ground cable	No	1.5m



Test Setup Diagram - Radiated Test > 1GHz

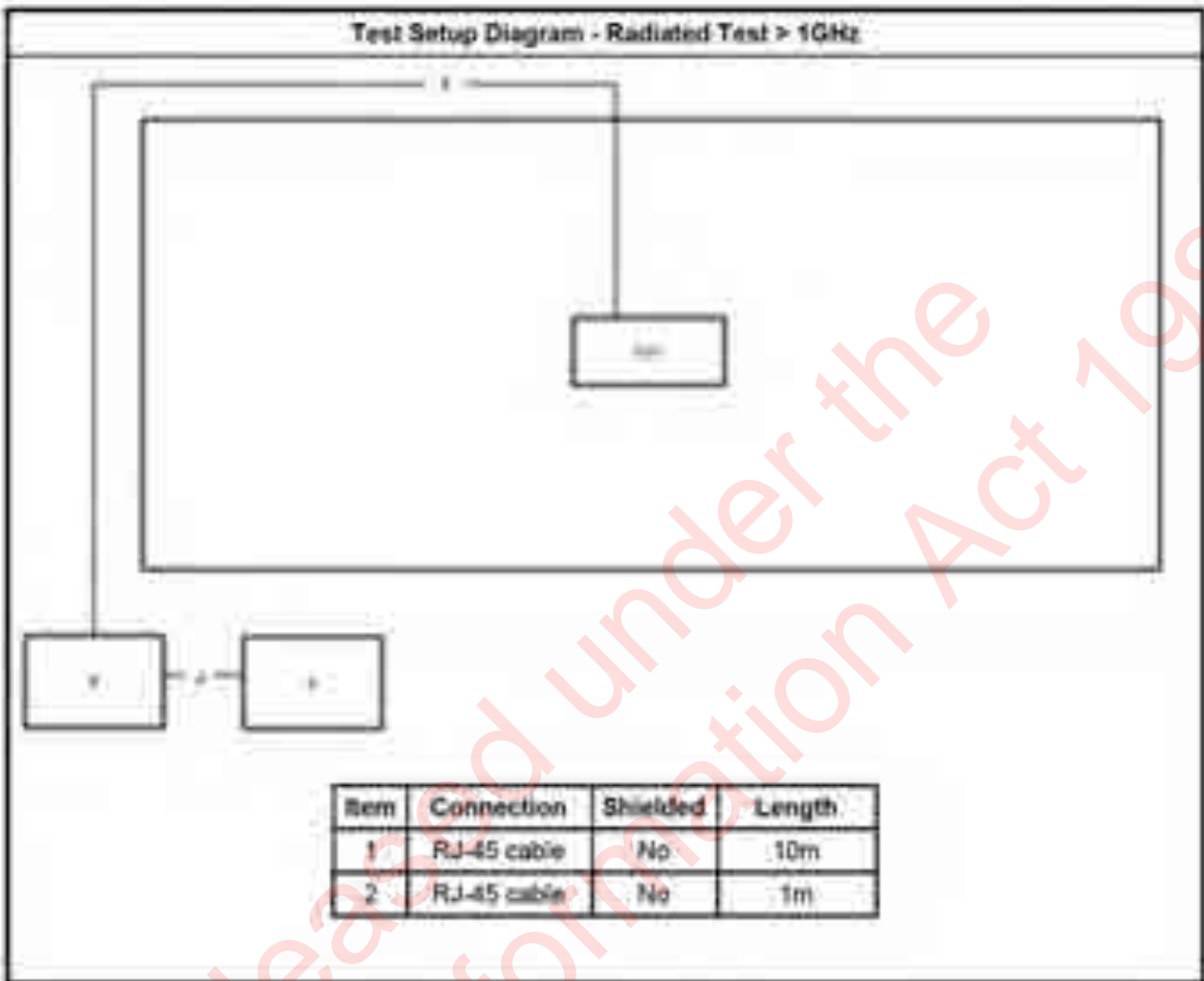

Released under the Official Information Act 1982

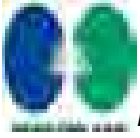

3 Transmitter Test Result

3.1 AC Power-line Conducted Emissions

3.1.1 AC Power-line Conducted Emissions Limit

AC Power-line Conducted Emissions Limit		
Frequency Emission (MHz)	Quasi-Peak	Average
0.15-0.5	66 - 56 *	56 - 46 *
0.5-5	56	46
5-30	60	50

Note 1: * Decreases with the logarithm of the frequency.

3.1.2 Measuring Instruments

Refer a test equipment and calibration data table in this test report.

3.1.3 Test Procedures

Test Method
<input checked="" type="checkbox"/> Refer as ANSI C63.10-2013, clause 6.2 for AC power-line conducted emissions.

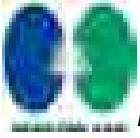

3.1.4 Test Setup

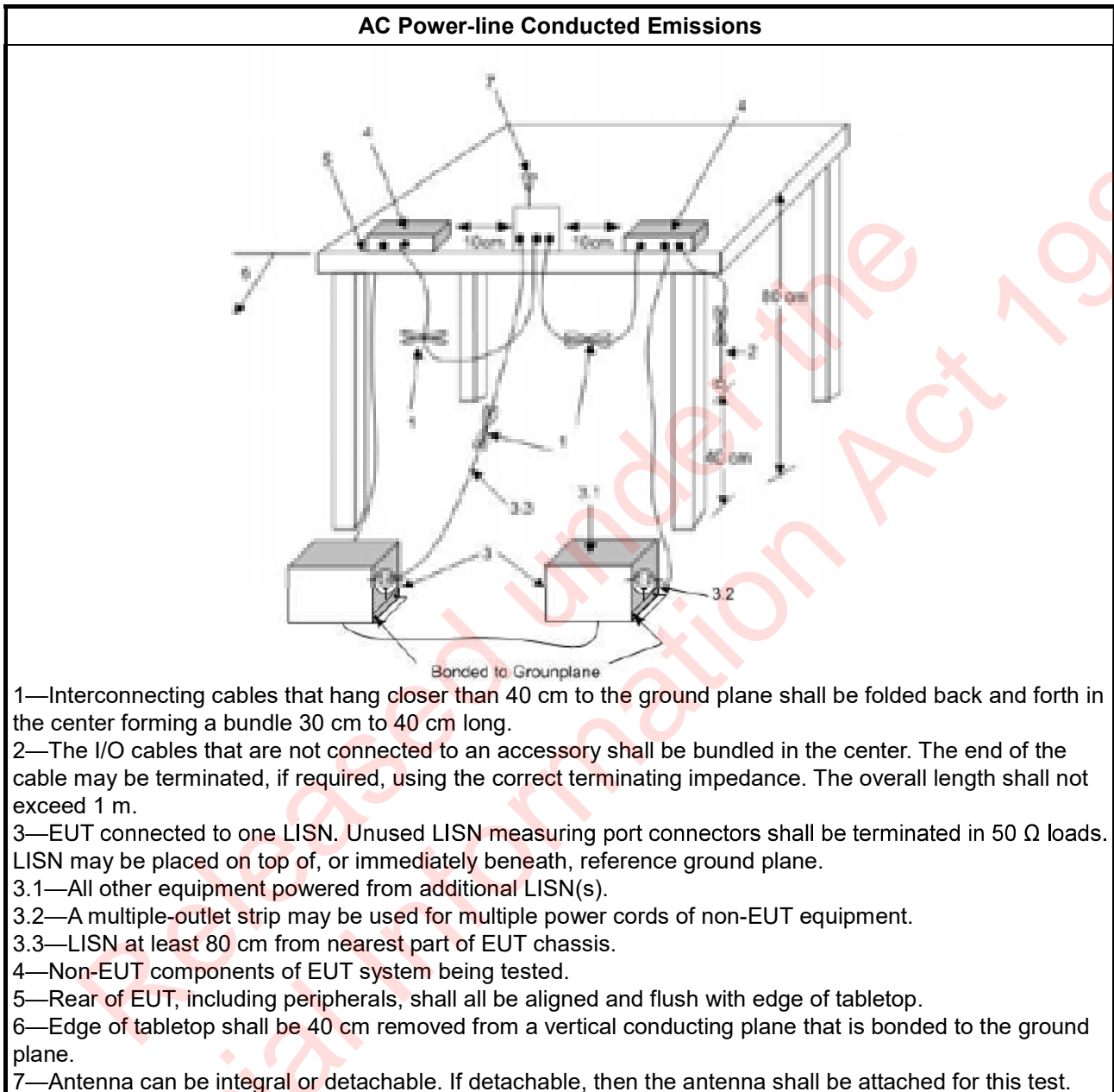

3.1.5 Measurement Results Calculation

The measured Level is calculated using:

- a. Corrected Reading (dBuV) = LISN Factor + Cable Loss + Read Level = Level
- b. Margin = - Limit + (Read Level + LISN Factor + Cable Loss)

3.1.6 Test Result of AC Power-line Conducted Emissions

Refer as Appendix A



3.2 Emission Bandwidth

3.2.1 Emission Bandwidth Limit

Emission Bandwidth Limit	
UNII Devices	
<input checked="" type="checkbox"/>	For the 5925-6425 GHz band, N/A
<input type="checkbox"/>	For the 6425-6525 GHz band, N/A
<input checked="" type="checkbox"/>	For the 6525-6875 GHz band, N/A
<input type="checkbox"/>	For the 6875-7125 GHz band, N/A
RLAN Devices	
<input type="checkbox"/>	For the 5925-6425 GHz band, N/A
<input type="checkbox"/>	For the 6425-6525 GHz band, N/A
<input type="checkbox"/>	For the 6525-6875 GHz band, N/A
<input type="checkbox"/>	For the 6875-7125 GHz band, N/A

3.2.2 Measuring Instruments

Refer a test equipment and calibration data table in this test report.

3.2.3 Test Procedures

Test Method	
• For the emission bandwidth shall be measured using one of the options below:	
<input checked="" type="checkbox"/>	According to FCC KDB 967594 D02 clause II.C, measurement procedure shall refer to FCC KDB 789033 D02, clause C for EBW and clause D for OBW measurement.
<input type="checkbox"/>	Refer as ANSI C63.10, clause B.9.1 for occupied bandwidth testing.
<input type="checkbox"/>	Refer as IC RSS-Gen, clause 4.6 for bandwidth testing.

3.2.4 Test Setup

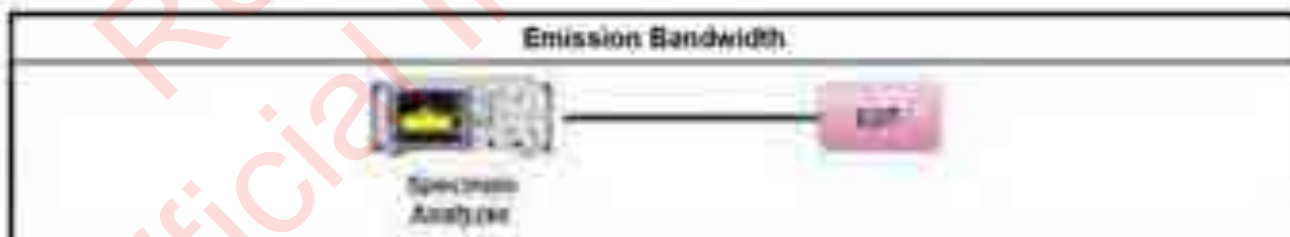

3.2.5 Test Result of Emission Bandwidth

Refer as Appendix B

**3.3 Maximum Equivalent Isotropically Radiated Power (E.I.R.P.)****3.3.1 Maximum Equivalent Isotropically Radiated Power (E.I.R.P.) Limit**

Maximum Equivalent Isotropically Radiated Power (E.I.R.P.) Limit.	
UNII Devices	
<input checked="" type="checkbox"/>	For the 5.925 ~ 6.425 GHz band
<ul style="list-style-type: none">• For standard power access point and fixed client device : e.i.r.p. < 36 dBm. For outdoor devices, the maximum e.i.r.p. at any elevation angle above 30 degrees not exceed 125 mW (21 dBm).• For indoor access point : e.i.r.p. < 30 dBm.• For subordinate device control of an indoor access point : e.i.r.p. < 30 dBm.• For client device control of a standard power access point : e.i.r.p. < 30 dBm.• For client device control of an indoor access point : e.i.r.p. < 24 dBm.• For very low power device : e.i.r.p. < 14 dBm.	
<input type="checkbox"/>	For the 6.425 ~ 6.525 GHz band
<ul style="list-style-type: none">• For indoor access point : e.i.r.p. < 30 dBm.• For client device control of an indoor access point : e.i.r.p. < 24 dBm.	
<input checked="" type="checkbox"/>	For the 6.525 ~ 6.875 GHz band
<ul style="list-style-type: none">• For standard power access point and fixed client device : e.i.r.p. < 36 dBm. For outdoor devices, the maximum e.i.r.p. at any elevation angle above 30 degrees not exceed 125 mW (21 dBm).• For indoor access point : e.i.r.p. < 30 dBm.• For subordinate device control of an indoor access point : e.i.r.p. < 30 dBm.• For client device control of a standard power access point : e.i.r.p. < 30 dBm.• For client device control of an indoor access point : e.i.r.p. < 24 dBm.• For very low power device : e.i.r.p. < 14 dBm.	
<input type="checkbox"/>	For the 6.875 ~ 7.125 GHz band
<ul style="list-style-type: none">• For indoor access point : e.i.r.p. < 30 dBm.• For client device control of an indoor access point : e.i.r.p. < 24 dBm.	
RLAN Devices	
<input type="checkbox"/>	For the 5.925 ~ 7.125 GHz band
<ul style="list-style-type: none">• For low-power indoor access-points & indoor subordinate devices < 30 dBm.• For low-power client devices < 24 dBm.	
<input type="checkbox"/>	For the 5.925 ~ 6.875 GHz band
<ul style="list-style-type: none">• For standard-power access points & fixed client devices < 36 dBm. For outdoor devices, the maximum e.i.r.p. at any elevation angle above 30 degrees not exceed 125 mW (21 dBm).• For standard client devices < 30 dBm.	



3.3.2 Measuring Instruments

Refer a test equipment and calibration data table in this test report.

3.3.3 Test Procedures

Test Method	
<ul style="list-style-type: none"> According to FCC KDB 987594 D02 clause II.E, the test measurement procedure shall refer to KDB 789033. 	
Average over on/off periods with duty factor	
<input type="checkbox"/>	Refer as FCC KDB 789033 D02, clause E Method SA-2 (spectral trace averaging). Spectrum analyzer setting: RBW/BBW : 1/3MHz; Detector : RMS; Trace mode : Average; Sweep Count 100.
<input type="checkbox"/>	Refer as FCC KDB 789033 D02, clause E Method SA-2 Alt. (RMS detection with slow sweep speed)
Wideband RF power meter and average over on/off periods with duty factor	
<input checked="" type="checkbox"/>	Refer as FCC KDB 789033 D02, clause E Method PM-G (using an RF average power meter).
<input checked="" type="checkbox"/>	For conducted measurement:
<ul style="list-style-type: none"> If the EUT supports multiple transmit chains using options given below: Refer as FCC KDB 662911, In-band power measurements. Using the measure-and-sum approach, measured all transmit ports individually. Sum the power (in linear power units e.g., mW) of all ports for each individual sample and save them. If multiple transmit chains, EIRP calculation could be following as methods $P_{total} = P_1 + P_2 + \dots + P_n$ (calculated in linear unit [mW] and transfer to log unit [dBm]) $EIRP_{total} = P_{total} + DG$ 	
<input type="checkbox"/>	For radiated measurement:
<ul style="list-style-type: none"> Refer as FCC KDB 789033 D02 clause II A.1.F "Antenna-port Conducted versus Radiated Testing" Refer as ANSI C63.10, clause 6.6 for radiated emissions above 1GHz. Refer as FCC KDB 412172 D01 clause 2.2 for EIRP calculation. 	

3.3.4 Test Setup

Conducted Measurement (Power Meter)

3.3.5 Test Result of Maximum Equivalent Isotropically Radiated Power (E.I.R.P)

Refer as Appendix C



3.4 Peak Power Spectral Density (E.I.R.P.)

3.4.1 Peak Power Spectral Density (E.I.R.P.) Limit

Peak Power Spectral Density (E.I.R.P.) Limit	
UNII Devices	
<input checked="" type="checkbox"/>	For the 5.925 ~ 6.425 GHz band:
	<ul style="list-style-type: none"> For standard power access point and fixed client device : e.i.r.p PSD < 23 dBm/MHz. For indoor access point : e.i.r.p PSD < 5 dBm/MHz. For subordinate device control of an indoor access point : e.i.r.p PSD < 5 dBm/MHz. For client device control of a standard power access point : e.i.r.p PSD < 17 dBm/MHz. For client device control of an indoor access point : e.i.r.p PSD < -1 dBm/MHz. For very low power device : e.i.r.p PSD < -5 dBm/MHz.
<input type="checkbox"/>	For the 6.425 ~ 6.525 GHz band:
	<ul style="list-style-type: none"> For indoor access point : e.i.r.p PSD < 5 dBm/MHz. For client device control of an indoor access point : e.i.r.p PSD < -1 dBm/MHz.
<input checked="" type="checkbox"/>	For the 6.525 ~ 6.875 GHz band:
	<ul style="list-style-type: none"> For standard power access point and fixed client device : e.i.r.p PSD < 23 dBm/MHz. For indoor access point : e.i.r.p PSD < 5 dBm/MHz. For subordinate device control of an indoor access point : e.i.r.p PSD < 5 dBm/MHz. For client device control of a standard power access point : e.i.r.p PSD < 17 dBm/MHz. For client device control of an indoor access point : e.i.r.p PSD < -1 dBm/MHz. For very low power device : e.i.r.p PSD < -5 dBm/MHz.
<input type="checkbox"/>	For the 6.875 ~ 7.125 GHz band:
	<ul style="list-style-type: none"> For indoor access point : e.i.r.p PSD < 5 dBm/MHz. For client device control of an indoor access point : e.i.r.p PSD < -1 dBm/MHz.
RLAN Devices	
<input type="checkbox"/>	For the 5.925 ~ 7.125 GHz band:
	<ul style="list-style-type: none"> For low-power indoor access-points & indoor subordinate devices < 5 dBm / MHz. For low-power client devices < -1 dBm / MHz.
<input type="checkbox"/>	For the 5.925 ~ 6.875 GHz band:
	<ul style="list-style-type: none"> For standard-power access points & fixed client devices < 23 dBm / MHz. For standard client devices < 17 dBm / MHz.

3.4.2 Measuring Instruments

Refer a test equipment and calibration data table in this test report.



3.4.3 Test Procedures

Test Method
<ul style="list-style-type: none"> According to FCC KDB 987594 D02 clause II.F, the measurement procedure shall refer to KDB 789033. Peak power spectral density procedures that the same method as used to determine the conducted output power shall be used to determine the peak power spectral density and use the peak search function on the spectrum analyzer to find the peak of the spectrum. For the peak power spectral density shall be measured using below options:
<input type="checkbox"/> Refer as FCC KDB 789033 D02, F(5) power spectral density can be measured using resolution bandwidths < 1 MHz provided that the results are integrated over 1 MHz bandwidth [duty cycle ≥ 98% or external video / power trigger]
<input checked="" type="checkbox"/> Refer as FCC KDB 789033 D02, clause E Method SA-1 (spectral trace averaging).
<input type="checkbox"/> Refer as FCC KDB 789033 D02, clause E Method SA-1 Alt. (RMS detection with slow sweep speed) duty cycle < 98% and average over on/off periods with duty factor
<input checked="" type="checkbox"/> Refer as FCC KDB 789033 D02, clause E Method SA-2 (spectral trace averaging).
<input type="checkbox"/> Refer as FCC KDB 789033 D02, clause E Method SA-2 Alt. (RMS detection with slow sweep speed)
<input checked="" type="checkbox"/> For conducted measurement.
<ul style="list-style-type: none"> If the EUT supports multiple transmit chains using options given below: <ul style="list-style-type: none"> <input checked="" type="checkbox"/> Option 1: Measure and sum the spectra across the outputs. Refer as FCC KDB 662911, In-band power spectral density (PSD). Sample all transmit ports simultaneously using a spectrum analyzer for each transmit port. Where the trace bin-by-bin of each transmit port summing can be performed. (i.e., in the first spectral bin of output 1 is summed with that in the first spectral bin of output 2 and that from the first spectral bin of output 3, and so on up to the Nth output to obtain the value for the first frequency bin of the summed spectrum.) Add up the amplitude (power) values for the different transmit chains and use this as the new data trace. <input type="checkbox"/> Option 2: Measure and sum spectral maxima across the outputs. With this technique, spectra are measured at each output of the device at the required resolution bandwidth. The maximum value (peak) of each spectrum is determined. These maximum values are then summed mathematically in linear power units across the outputs. These operations shall be performed separately over frequency spans that have different out-of-band or spurious emission limits. <input type="checkbox"/> Option 3: Measure and add 10 log(N) dB, where N is the number of transmit chains. Refer as FCC KDB 662911, In-band power spectral density (PSD). Performed at each transmit chains and each transmit chains shall be compared with the limit have been reduced with 10 log(N). Or each transmit chains shall be add 10 log(N) to compared with the limit. If multiple transmit chains, EIRP PPSD calculation could be following as methods: $PPSD_{total} = PPSD_1 + PPSD_2 + \dots + PPSD_n$ (calculated in linear unit [mW] and transfer to log unit [dBm]) $EIRP_{total} = PPSD_{total} + DG$
<input type="checkbox"/> For radiated measurement.
<ul style="list-style-type: none"> Refer as FCC KDB 789033 D02 clause II.A.1.F "Antenna-port Conducted versus Radiated Testing" Refer as ANSI C63.10, clause 6.6 for radiated emissions above 1GHz.

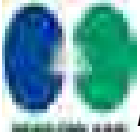

Test Method	
	▪ Refer as FCC KDB 412172 D01 clause 2.2 for EIRP calculation.

3.4.4 Test Setup

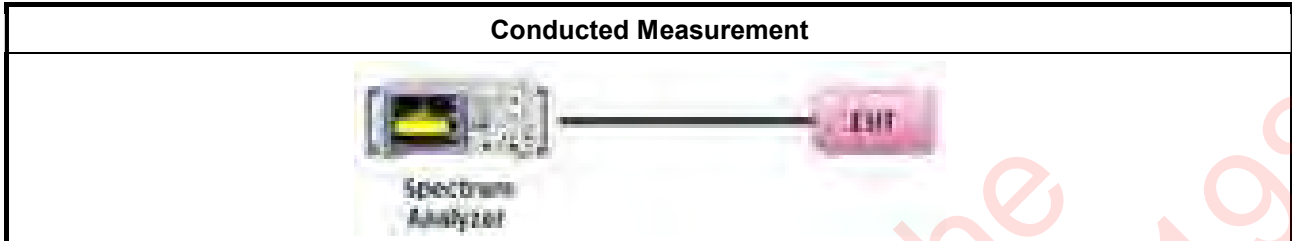

3.4.5 Test Result of Peak Power Spectral Density (E.I.R.P.)

Refer as Appendix D

Released under the Official Information Act 1982

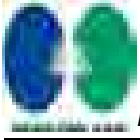

3.5 Unwanted Emissions

3.5.1 Transmitter Unwanted Emissions Limit

Unwanted emissions below 1 GHz and restricted band emissions above 1GHz limit			
Frequency Range (MHz)	Field Strength (uV/m)	Field Strength (dBuV/m)	Measure Distance (m)
0.009~0.490	2400/F(kHz)	48.5 - 13.8	300
0.490~1.705	24000/F(kHz)	33.8 - 23	30
1.705~30.0	30	29	30
30~88	100	40	3
88~216	150	43.5	3
216~960	200	46	3
Above 960	500	54	3

Note 1: Test distance for frequencies at or above 30 MHz, measurements may be performed at a distance other than the limit distance provided they are not performed in the near field and the emissions to be measured can be detected by the measurement equipment. When performing measurements at a distance other than that specified, the results shall be extrapolated to the specified distance using an extrapolation factor of 20 dB/decade (inverse of linear distance for field-strength measurements, inverse of linear distance-squared for power-density measurements).

Note 2: Test distance for frequencies at below 30 MHz, measurements may be performed at a distance closer than the EUT limit distance; however, an attempt should be made to avoid making measurements in the near field. When performing measurements below 30 MHz at a closer distance than the limit distance, the results shall be extrapolated to the specified distance by either making measurements at a minimum of two or more distances on at least one radial to determine the proper extrapolation factor or by using the square of an inverse linear distance extrapolation factor (40 dB/decade). The test report shall specify the extrapolation method used to determine compliance of the EUT.

Note 3: Using the distance of 1m during the test for above 18 GHz, and the test value to correct for the distance factor at 3m($20 \times \log(\text{standard distance}/\text{test distance}) = 20\log(3/1) = 9.54\text{dB}$).
EX. Above 18GHz emission limit calculation (3m to 1m) = $54\text{dBuV/m at 3m} + 9.54\text{dB} = 63.54\text{ dBuV/m at 1m}$.

Un-restricted band emissions above 1GHz Limit	
Frequency	Limit
Any outside the 5.945 – 7.125 GHz emission	<p>e.i.r.p. -27 dBm [68.2 dBuV/m@3m]</p> <p>Note 1: Using the distance of 1m during the test for above 18 GHz, and the test value to correct for the distance factor at 3m($20 \times \log(\text{standard distance}/\text{test distance}) = 20\log(3/1) = 9.54\text{dB}$). EX. Above 18GHz emission limit calculation (3m to 1m) = $68.2\text{dBuV/m at 3m} + 9.54\text{dB} = 77.74\text{ dBuV/m at 1m}$.</p> <p>Note 2:-27 dBm EIRP OOBE is measured RMS which is a deviation from the current 15E rules for 5 GHz bands. In addition, 15.35(b) applies where the peak emissions must be limited to no more than 20 dB above the average limit.</p>

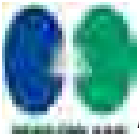

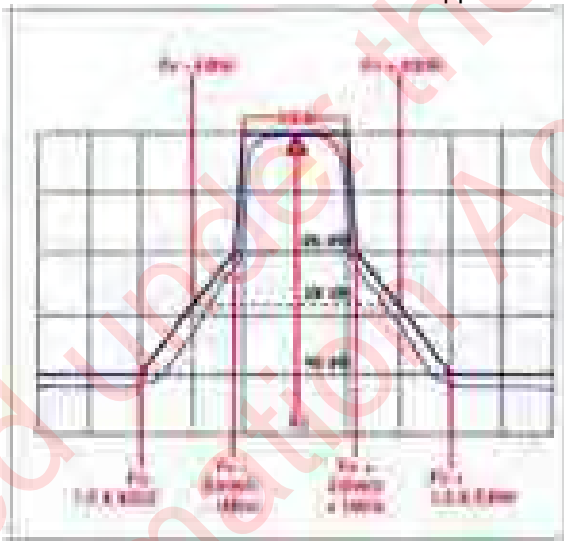
Frequency	Emission MASK Limit
5.945 – 7.125 GHz	<p>Power spectral density must be suppressed by 20 dB at 1 MHz outside of channel edge, by 28 dB at one channel bandwidth from the channel center, and by 40 dB at one- and one-half times the channel bandwidth away from channel center. At frequencies between one megahertz outside an unlicensed device's channel edge and one channel bandwidth from the center of the channel, the limits must be linearly interpolated between 20 dB and 28 dB suppression, and at frequencies between one and one- and one-half times an unlicensed device's channel bandwidth, the limits must be linearly interpolated between 28 dB and 40 dB suppression. Emissions removed from the channel center by more than one- and one-half times the channel bandwidth must be suppressed by at least 40 dB.</p> 

Released Under the Official Information Act 1982



3.5.2 Measuring Instruments

Refer a test equipment and calibration data table in this test report.

3.5.3 Test Procedures

Test Method	
<ul style="list-style-type: none"> According to FCC KDB 987594 D02 II.G, the unwanted emission measurement procedure shall refer to KDB 789300(except emission MASK). Measurements may be performed at a distance other than the limit distance provided they are not performed in the near field and the emissions to be measured can be detected by the measurement equipment. Measurements shall not be performed at a distance greater than 30 m for frequencies above 30 MHz, unless it can be further demonstrated that measurements at a distance of 30 m or less are impractical. When performing measurements at a distance other than that specified, the results shall be extrapolated to the specified distance using an extrapolation factor of 20 dB/decade (inverse of linear distance for field-strength measurements, inverse of linear distance-squared for power-density measurements). 	
<ul style="list-style-type: none"> The average emission levels shall be measured in [duty cycle \geq 98 or duty factor]. 	
<ul style="list-style-type: none"> For the transmitter unwanted emissions shall be measured using following options below: <ul style="list-style-type: none"> Refer as FCC KDB 789033 D02, clause G)2) for unwanted emissions into non-restricted bands. Refer as FCC KDB 789033 D02, clause G)1) for unwanted emissions into restricted bands. <ul style="list-style-type: none"> <input checked="" type="checkbox"/> Refer as FCC KDB 789033 D02, G)6) Method AD (Trace Averaging). (For unrestricted band measurement) <input type="checkbox"/> Refer as FCC KDB 789033 D02, G)5) Method VB (Reduced VBW) <input checked="" type="checkbox"/> Refer as ANSI C63.10, clause 11.12.2.5.3 (Reduced VBW). VBW \geq 1/T, where T is pulse time. (For restricted band average measurement) <input type="checkbox"/> Refer as ANSI C63.10, clause 7.5 average value of pulsed emissions. <input checked="" type="checkbox"/> Refer as FCC KDB 789033 D02, clause G)5) measurement procedure peak limit. <input type="checkbox"/> Refer as ANSI C63.10, clause 4.1.4.2.2 measurement procedure peak limit. 	
<ul style="list-style-type: none"> Refer as FCC KDB 789033 D02, clause G)3)d)ii) for Band edge Integration measurements. 	
<ul style="list-style-type: none"> For emission MASK shall be measured using following options below: <ul style="list-style-type: none"> <input checked="" type="checkbox"/> Refer as FCC KDB 987594 D02, J) In-Band Emissions 	
<ul style="list-style-type: none"> For radiated measurement: <ul style="list-style-type: none"> Refer as ANSI C63.10, clause 8.4 for radiated emissions below 30 MHz and test distance is 3m. Refer as ANSI C63.10, clause 6.5 for radiated emissions 30 MHz to 1 GHz and test distance is 3m. Refer as ANSI C63.10, clause 6.6 for radiated emissions above 1GHz. 	
<ul style="list-style-type: none"> The any unwanted emissions level shall not exceed the fundamental emission level. 	
<ul style="list-style-type: none"> All amplitude of spurious emissions that are attenuated by more than 20 dB below the permissible value has no need to be reported. 	



3.5.4 Test Setup

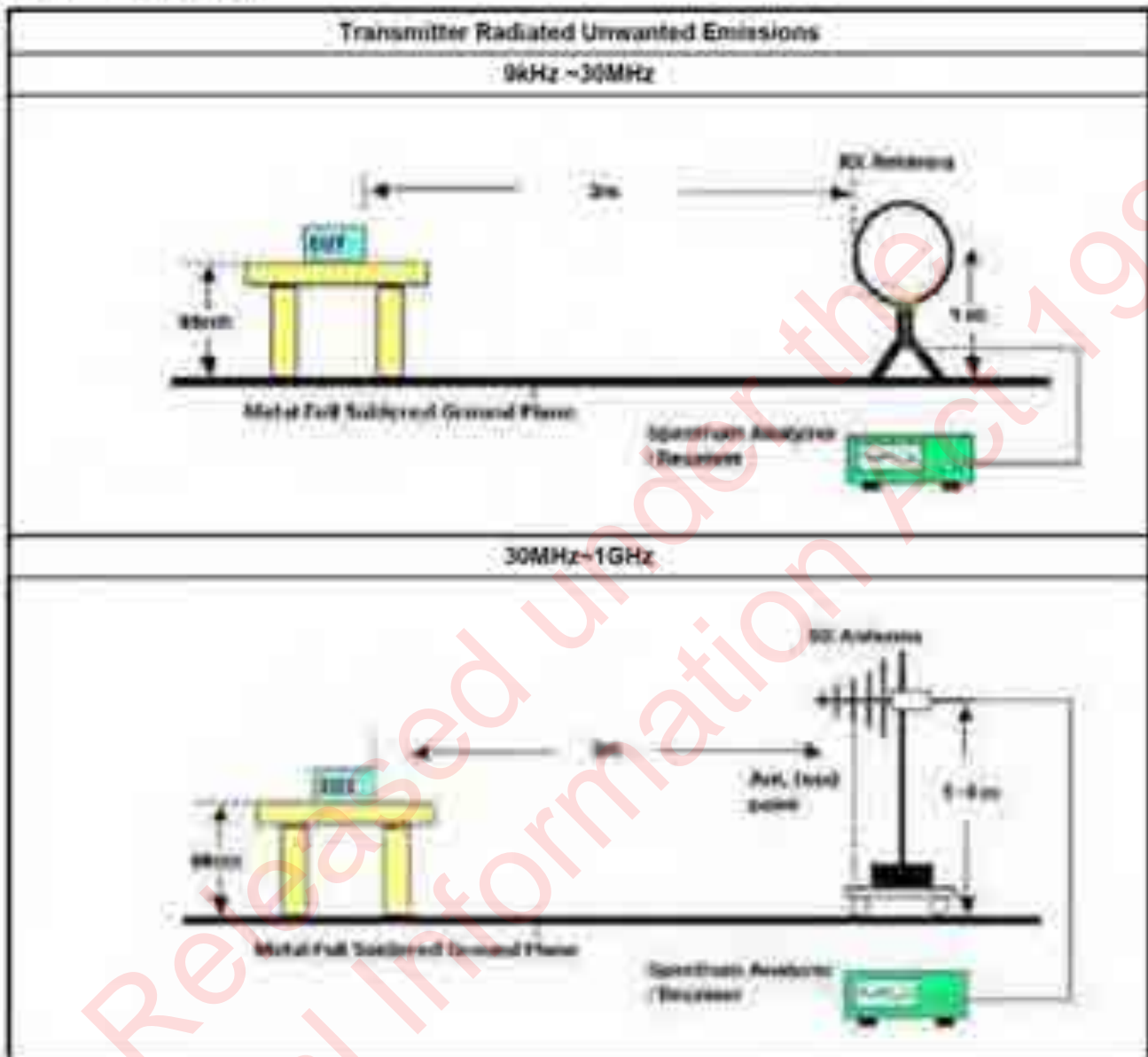

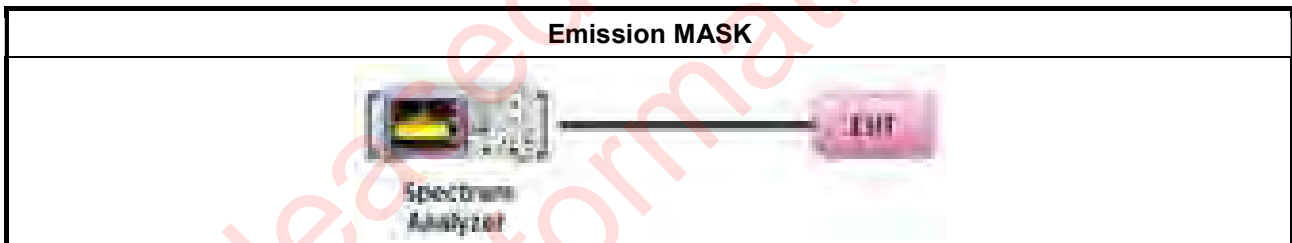
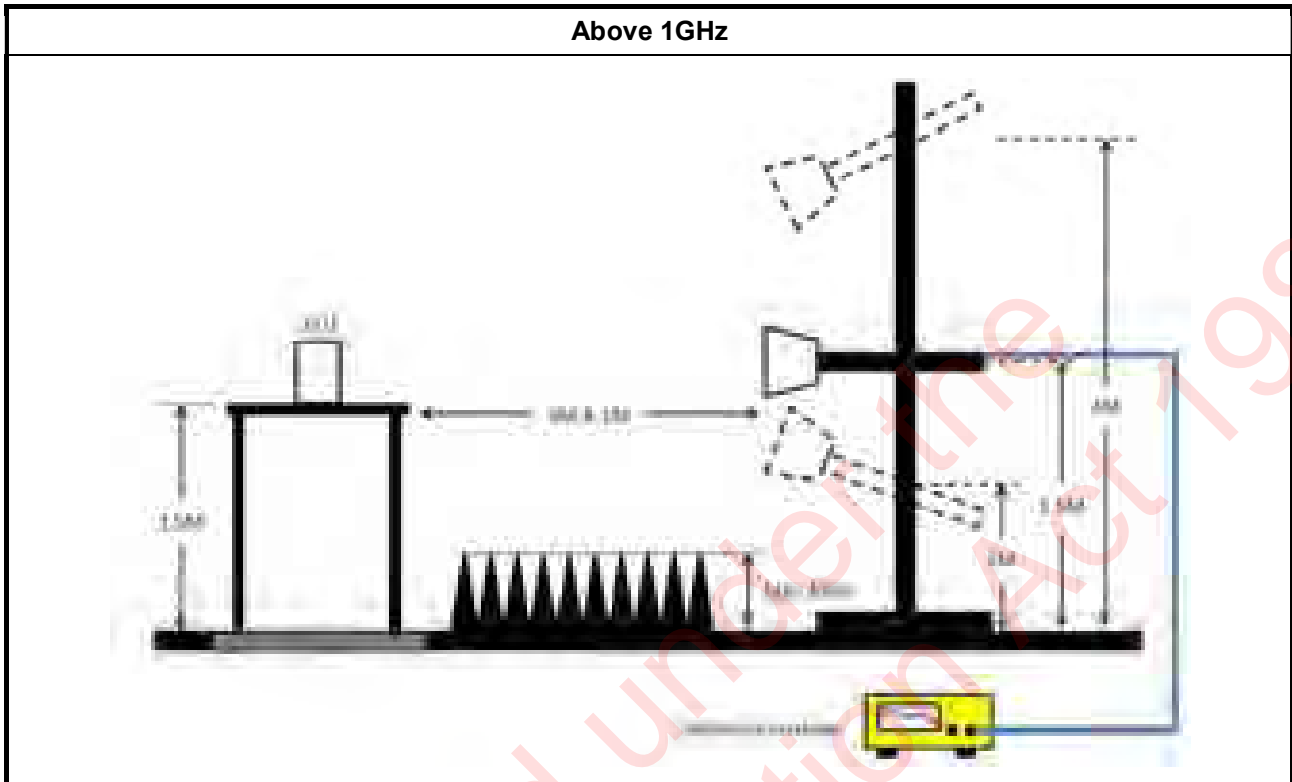
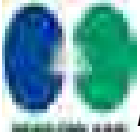

3.5.5 Measurement Results Calculation

The measured Level is calculated using:

Corrected Reading: Antenna factor (AF) + Cable loss (CL) + Read level (Raw) - Preamp factor (PA)(if applicable)
= Level

3.5.6 Transmitter Unwanted Emissions (Below 30MHz)

There is a comparison data of both open-field test site and alternative test site - semi-Anechoic chamber according to KDB414788 Radiated Test Site, and the result came out very similar.

All amplitude of spurious emissions that are attenuated by more than 20 dB below the permissible value has no need to be reported.

The radiated emissions were investigated from 9 kHz or the lowest frequency generated within the device, up to the 10th harmonic or 40 GHz, whichever is appropriate.

3.5.7 Test Result of Transmitter Unwanted Emissions

Refer as Appendix E

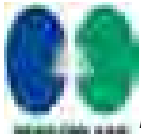

4 Test Equipment and Calibration Data

Instrument	Brand	Model No.	Serial No.	Characteristics	Calibration Date	Calibration Due Date	Remark
LISN	Schwarzbeck	NSLK 8127	8127650	9kHz ~ 30MHz	Apr. 06, 2023	Apr. 05, 2024	Conduction (CO02-CB)
LISN	Schwarzbeck	NSLK 8127	8127647	9kHz ~ 30MHz	Apr. 27, 2023	Apr. 26, 2024	Conduction (CO02-CB)
EMI Receiver	Agilent	N9038A	MY52260140	9kHz ~ 8.4GHz	May 18, 2023	May 17, 2024	Conduction (CO02-CB)
COND Cable	Woken	Cable	2	0.15MHz ~ 30MHz	Oct. 17, 2023	Oct. 16, 2024	Conduction (CO02-CB)
Pulse Limiter	Schwarzbeck	VTSD 9561F-N	00378	9kHz ~ 30MHz	Oct. 17, 2023	Oct. 16, 2024	Conduction (CO02-CB)
Software	SPORTON	SENSE	V5.10	-	N.C.R.	N.C.R.	Conduction (CO02-CB)
Loop Antenna	Teseq	HLA 6121	65417	9kHz - 30 MHz	Oct. 13, 2023	Oct. 12, 2024	Radiation (10CH01-CB)
10m Semi Anechoic Chamber NSA	TDK	SAC-10M	10CH01-CB	30MHz~1GHz 10m,3m	Jan. 18, 2023	Jan. 17, 2024	Radiation (10CH01-CB)
Amplifier	Agilent	8447D	2944A10783	9kHz ~ 1.3GHz	Mar. 10, 2023	Mar. 09, 2024	Radiation (10CH01-CB)
Amplifier	Agilent	8447D	2944A10784	9kHz ~ 1.3GHz	Mar. 10, 2023	Mar. 09, 2024	Radiation (10CH01-CB)
Low Cable	Woken	SUCOFLEX 104	low cable-01	25MHz ~ 1GHz	Oct. 17, 2023	Oct. 16, 2024	Radiation (10CH01-CB)
Low Cable	Woken	SUCOFLEX 104	low cable-02	25MHz ~ 1GHz	Oct. 17, 2023	Oct. 16, 2024	Radiation (10CH01-CB)
Biconical Antenna	Schwarzbeck	VHBB 9124	324	30MHz ~ 200MHz	May 02, 2023	May 01, 2024	Radiation (10CH01-CB)
Log Antenna	Schwarzbeck	VUSLP 9111	247	200MHz ~ 1GHz	May 02, 2023	May 01, 2024	Radiation (10CH01-CB)
EMI Test Receiver	Rohde&Schwarz	ESCI	100186	9kHz ~ 3GHz	Jul. 11, 2023	Jul. 10, 2024	Radiation (10CH01-CB)
Spectrum Analyzer	Rohde&Schwarz	FSV30	101026	9kHz ~ 30GHz	Apr. 19, 2023	Apr. 18, 2024	Radiation (10CH01-CB)
Software	SPORTON	SENSE	V5.10	-	N.C.R.	N.C.R.	Radiation (10CH01-CB)
3m Semi Anechoic Chamber VSWR	TDK	SAC-3M	03CH03-CB	1GHz ~18GHz 3m	May 04, 2023	May 03, 2024	Radiation (03CH03-CB)
Horn Antenna	ETS-Lindgren	3115	6821	750MHz~ 18GHz	Feb. 03, 2023	Feb. 02, 2024	Radiation (03CH03-CB)

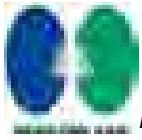

RADIO TEST REPORT

Report No. : FR380235-01

Instrument	Brand	Model No.	Serial No.	Characteristics	Calibration Date	Calibration Due Date	Remark
Horn Antenna	Schwarzbeck	BBHA 9170	BBHA9170252	15GHz ~ 40GHz	Sep. 04, 2023	Sep. 03, 2024	Radiation (03CH03-CB)
Pre-Amplifier	Agilent	8449B	3008A02097	1GHz ~ 26.5GHz	Jun. 30, 2023	Jun. 29, 2024	Radiation (03CH03-CB)
Pre-Amplifier	SGH	SGH184	20221107-3	18GHz ~ 40GHz	Nov. 16, 2022	Nov. 15, 2023	Radiation (03CH03-CB)
Spectrum Analyzer	R&S	FSP40	100019	9kHz ~ 40GHz	Jun. 12, 2023	Jun. 11, 2024	Radiation (03CH03-CB)
RF Cable-high	Woken	RG402	High Cable-20+29	1GHz ~ 18GHz	Oct. 02, 2023	Oct. 01, 2024	Radiation (03CH03-CB)
RF Cable-high	Woken	RG402	High Cable-29	1GHz ~ 18GHz	Oct. 02, 2023	Oct. 01, 2024	Radiation (03CH03-CB)
High Cable	Woken	WCA0929M	40G#5+6	1GHz ~ 40 GHz	Oct. 02, 2023	Oct. 01, 2024	Radiation (03CH03-CB)
High Cable	Woken	WCA0929M	40G#5	1GHz ~ 40 GHz	Oct. 02, 2023	Oct. 01, 2024	Radiation (03CH03-CB)
High Cable	Woken	WCA0929M	40G#6	1GHz ~ 40 GHz	Oct. 02, 2023	Oct. 01, 2024	Radiation (03CH03-CB)
Test Software	SPORTON	SENSE	V5.10	-	N.C.R.	N.C.R.	Radiation (03CH03-CB)
Spectrum analyzer	R&S	FSV40	101028	9kHz~40GHz	Dec. 30, 2022	Dec. 29, 2023	Conducted (TH03-CB)
Spectrum analyzer	R&S	FSV40	101028	9kHz~40GHz	Dec. 22, 2023	Dec. 21, 2024	Conducted (TH03-CB)
Power Sensor	Anritsu	MA2411B	1726195	300MHz~40GHz	Sep. 04, 2023	Sep. 03, 2024	Conducted (TH03-CB)
Power Meter	Anritsu	ML2495A	1035008	300MHz~40GHz	Sep. 04, 2023	Sep. 03, 2024	Conducted (TH03-CB)
RF Cable	Woken	RG402	High Cable-11	30MHz ~18 GHz	Oct. 02, 2023	Oct. 01, 2024	Conducted (TH03-CB)
RF Cable	Woken	RG402	High Cable-12	30MHz ~18 GHz	Oct. 02, 2023	Oct. 01, 2024	Conducted (TH03-CB)
RF Cable	Woken	RG402	High Cable-13	30MHz ~18 GHz	Oct. 02, 2023	Oct. 01, 2024	Conducted (TH03-CB)
RF Cable-high	Woken	RG402	High Cable-14	1 GHz ~18 GHz	Oct. 02, 2023	Oct. 01, 2024	Conducted (TH03-CB)
RF Cable-high	Woken	RG402	High Cable-15	1 GHz ~18 GHz	Oct. 02, 2023	Oct. 01, 2024	Conducted (TH03-CB)
Switch	SPTCB	SP-SWI	SWI-03	1 ~26.5 GHz	Oct. 03, 2023	Oct. 02, 2024	Conducted (TH03-CB)
Test Software	SPORTON	SENSE	V5.10	-	N.C.R.	N.C.R.	Conducted (TH03-CB)

Note: Calibration Interval of instruments listed above is one year.
NCR means Non-Calibration required.



Summary

Mode	Result	Type	Freq (Hz)	Level (dBuV)	Limit (dBuV)	Margin (dB)	Condition
Mode 1	Pass	QP	150k	56.15	66.00	-9.85	Line

Released under the
Official Information Act 1982



Table 1



Released under the
Official Information Act 1982

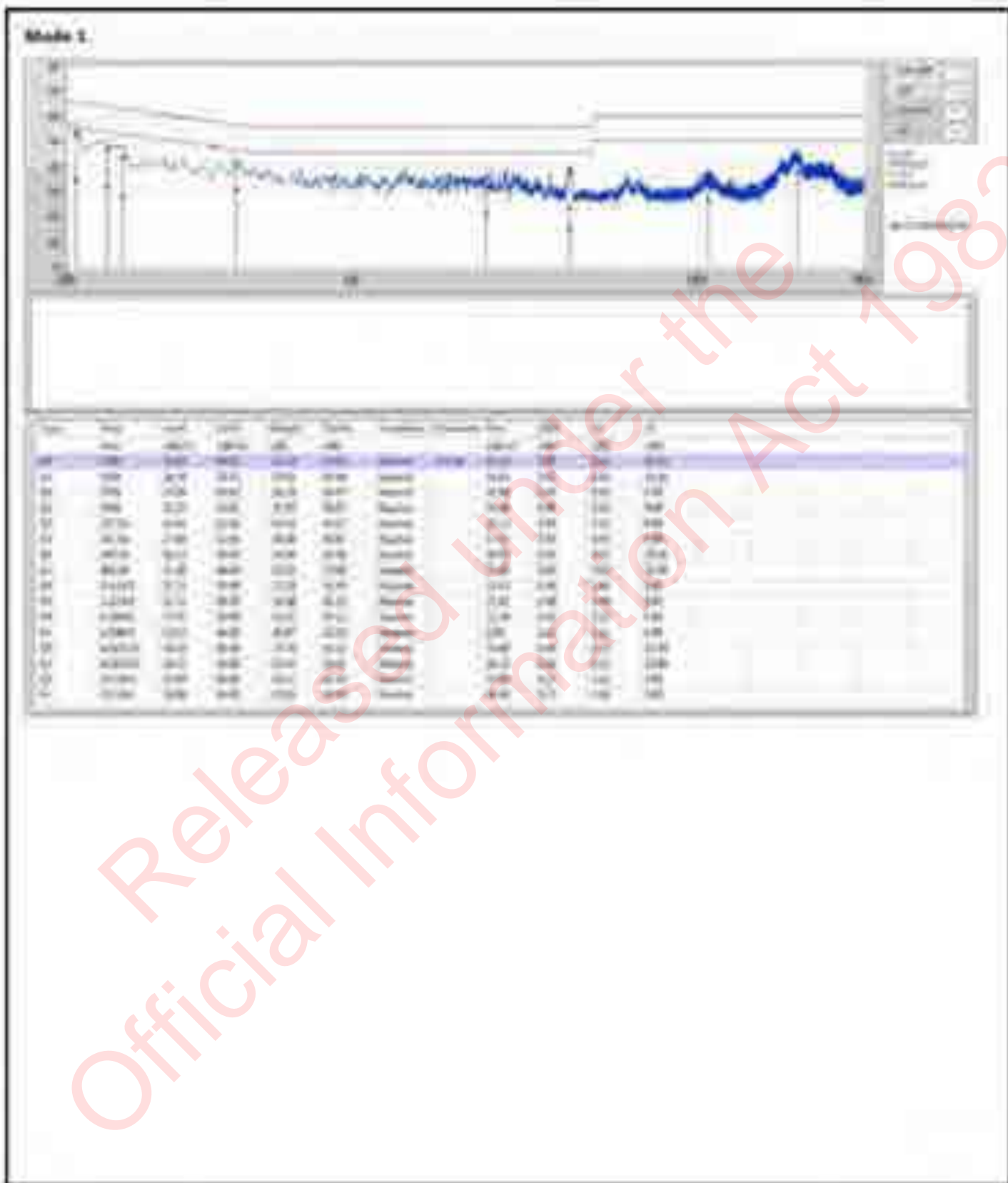



Summary

Model	Max-R 20 Psi	Max-ORR Psi	ITS-Code	Max-R 20 Psi	Max-ORR Psi
0254-ANDR	-	-	-	-	-
OP140 40Psi, No.1, 218	4,000	4,000	0800-01	4,000	4,000
OP140 40Psi, No.1, 218	3,000	3,000	0800-02	3,000	3,000
0254-ANDR	-	-	-	-	-
OP140 40Psi, No.1, 218	3,000	3,000	0800-03	3,000	3,000
OP140 40Psi, No.1, 218	3,000	3,000	0800-04	3,000	3,000

Max-R 20 - Maximum 20 psi pressure
 Max-ORR - Maximum ORR pressure
 ITS-Code - Material ID
 Max-R 20 - Maximum 20 psi pressure
 Max-ORR - Maximum ORR pressure

Released under the
 Official Information Act 1982



Result:

Male	Result	Unit	Pat 1-48	Pat 1-2008	Pat 2-48	Pat 1-2008
		mg	mg	mg	mg	mg
OPRID 3000, No. 1, 27X	→	→	→	→	→	→
3000mg	Pass	30	4.80M	1.10M	4.40M	1.20M
3100mg	Pass	30	4.41M	1.10M	1.10M	1.10M
4000mg	Pass	30	4.37M	1.10M	4.32M	1.10M
4000mg	Pass	30	4.75M	1.00M	1.00M	1.00M
4000mg	Pass	30	4.30M	1.10M	4.30M	1.20M
4000mg	Pass	30	4.47M	1.10M	4.32M	1.10M
OPRID 4000, No. 1, 27X	→	→	→	→	→	→
4000mg	Pass	30	11.10M	11.10M	11.10M	11.10M
4100mg	Pass	30	11.70M	11.10M	11.10M	11.10M
4000mg	Pass	30	11.10M	11.10M	11.10M	11.10M
4000mg	Pass	30	11.70M	11.10M	11.10M	11.10M
4000mg	Pass	30	11.10M	11.10M	11.10M	11.10M
4000mg (Sample 4 27X-4.2008)	Pass	30	11.10M	11.10M	11.10M	11.10M

Pat 1-48 = Pat 1-48 (uncontrolled) 1/27/08; Pat 1-2008 = Pat 1-2008 (uncontrolled) 1/27/08
 Pat 2-48 = Pat 2-48 (uncontrolled) 1/27/08

Released under the Official Information Act 1982

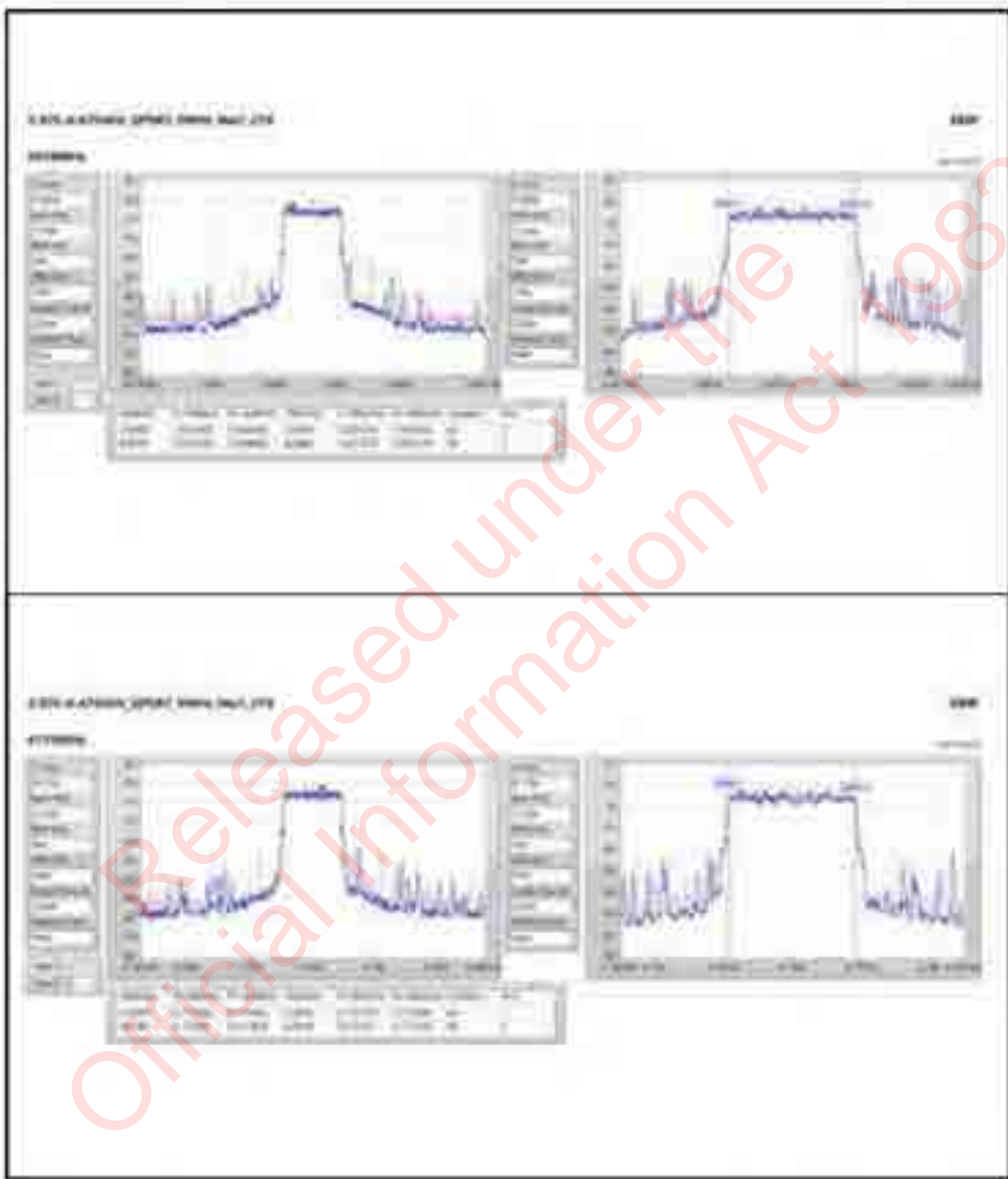

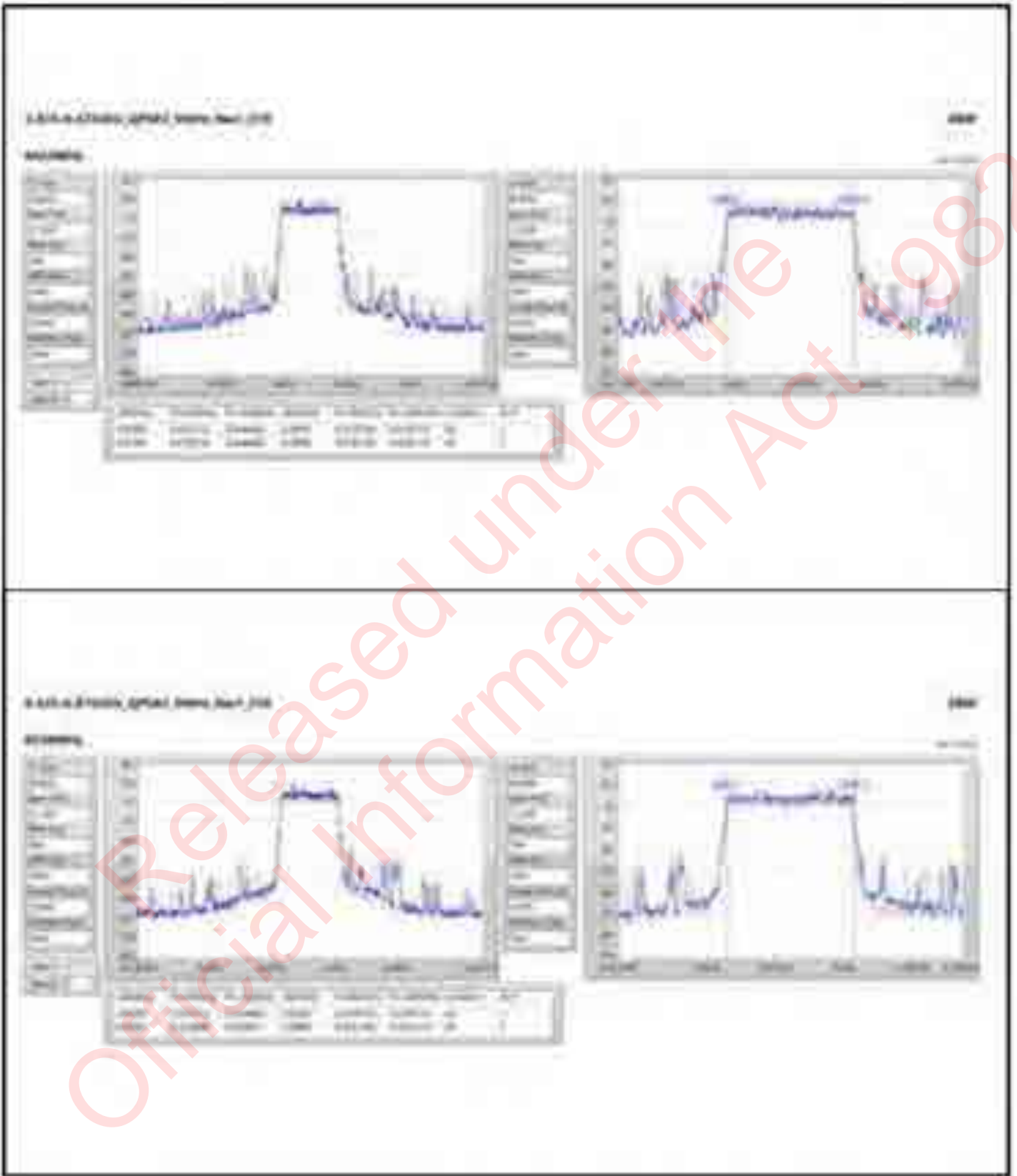

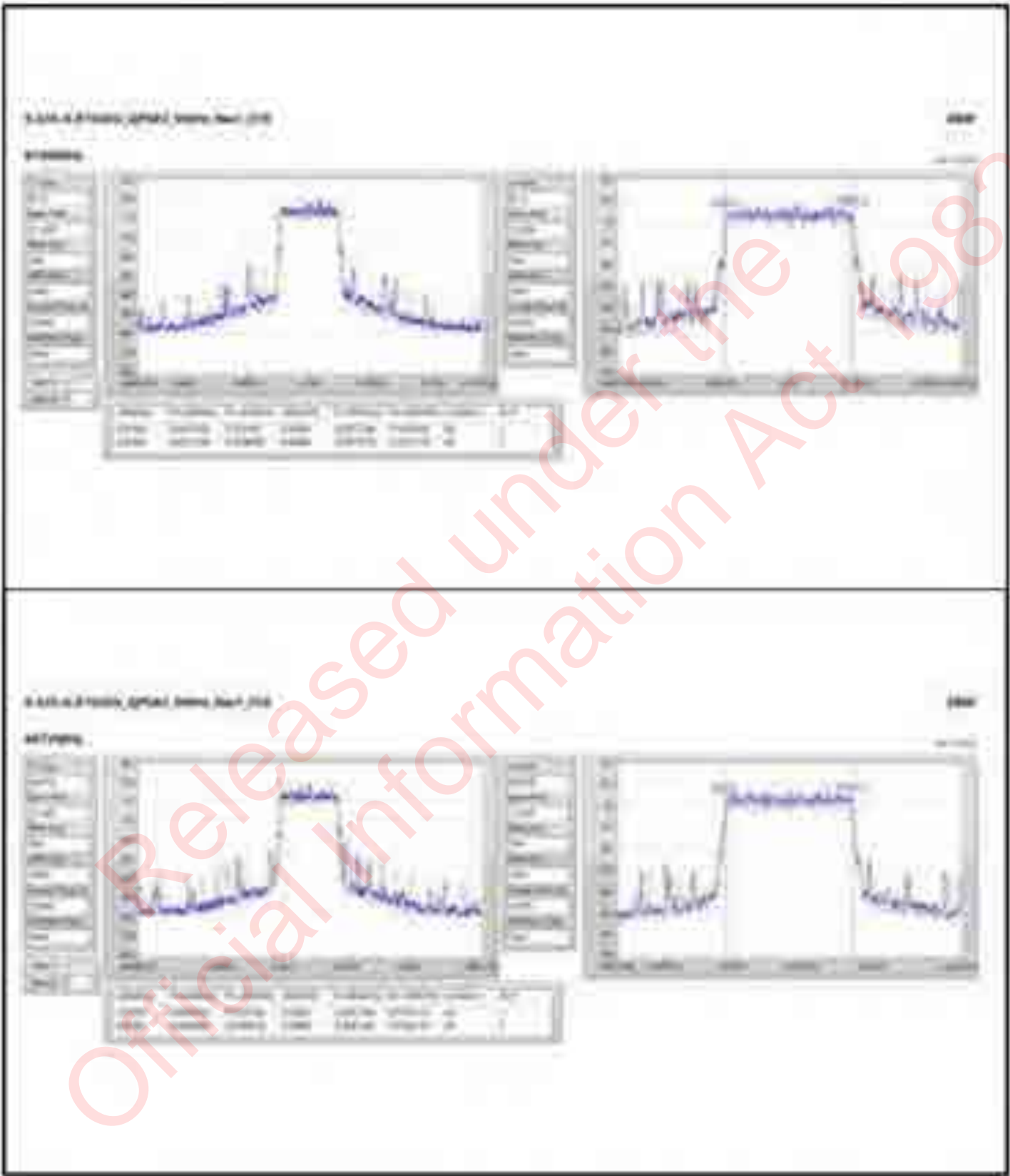

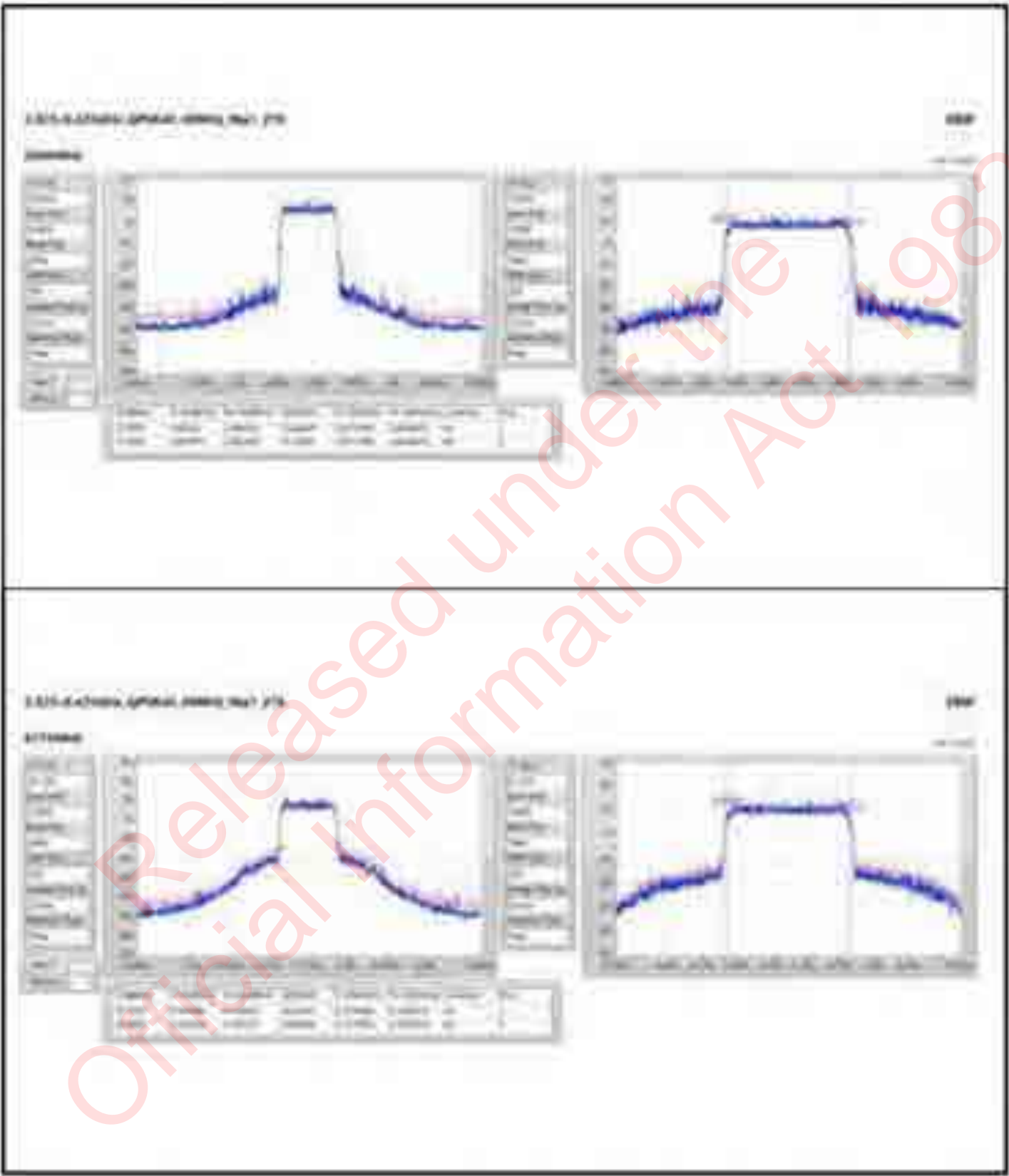

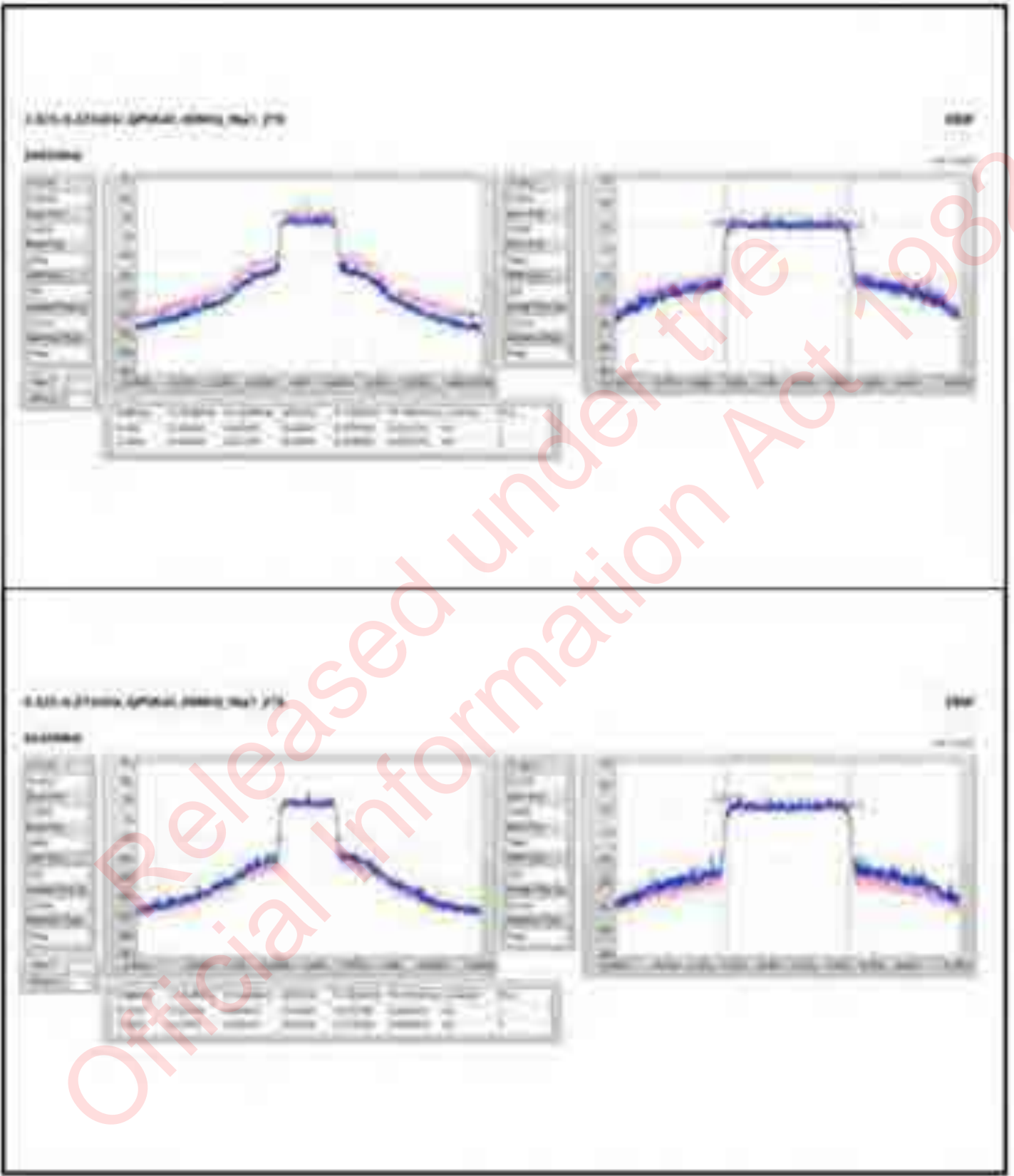

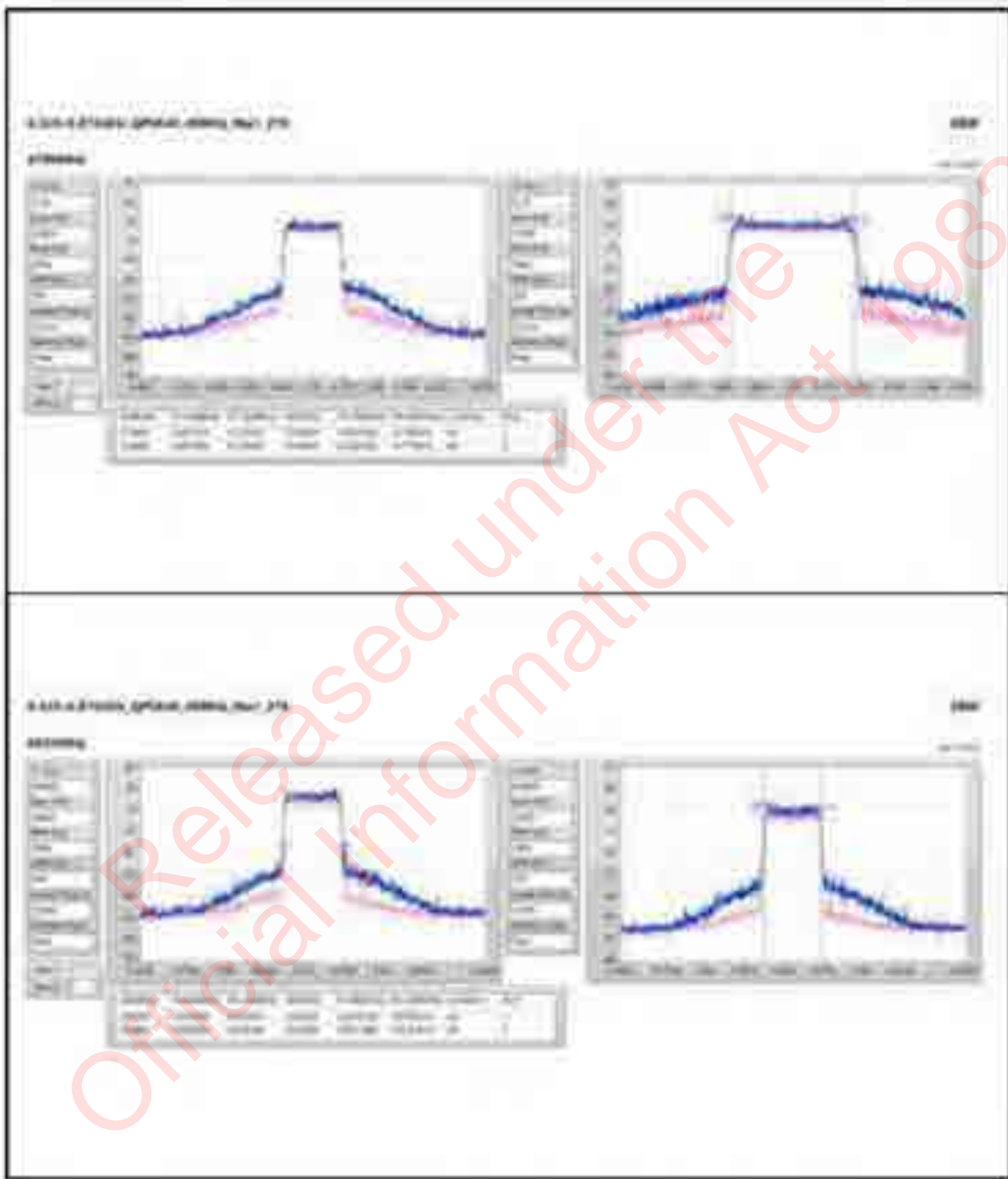



Summary

Sub	Total Power (W)	Total Power (mW)	(ERP / ERP (2% 30°)) (dBm)	(ERP / ERP (2% 30°)) (dB)
8.024-8.029	0	0	0	0
OPSA, 4000, 200, 273	14.02	4.0000	30.41734	1.0000000000
OPSA, 4000, 200, 273	14.02	4.0000	30.41734	1.0000000000
8.025-8.030	0	0	0	0
OPSA, 4000, 200, 273	14.02	4.0000	30.41734	1.0000000000
OPSA, 4000, 200, 273	14.02	4.0000	30.41734	1.0000000000

Released under the Official Information Act 1982



Result

Mod	Result	Directional Gain (Typical) / Gain (dB)	Port 1 (dBm)	Port 2 (dBm)	Total Power (dBm)	ERP / ERP (Pa 20)	ERP Class / ERP Class (Pa 20)
		(dB)	(dBm)	(dBm)	(dBm)	(dBm)	(dBm)
CPD40 40W, Surf, 1Tx							
2020Hz	Pass	11.956±0.08	11.12	11.26	11.21	30.137±0.20	30.007±0.00
2170Hz	Pass	11.956±0.08	11.81	11.56	11.63	30.137±0.20	30.007±0.00
4420Hz	Pass	11.956±0.08	12.01	11.48	11.48	30.137±0.20	30.007±0.00
4570Hz	Pass	11.956±0.08	11.70	11.29	11.29	30.137±0.20	30.007±0.00
21000Hz	Pass	11.956±0.11	11.85	11.86	11.85	30.137±0.20	30.007±0.00
48120Hz	Pass	11.956±0.11	11.85	11.50	11.63	30.137±0.20	30.007±0.00
CPD40 40W, Surf, 2Tx							
2020Hz	Pass	11.956±0.08	11.81	10.98	10.83	31.249±0.20	30.007±0.00
2170Hz	Pass	11.956±0.08	12.03	11.03	11.03	31.249±0.20	30.007±0.00
4420Hz	Pass	11.956±0.08	11.09	10.80	10.80	31.249±0.20	30.007±0.00
4570Hz	Pass	11.956±0.11	12.05	10.61	10.61	31.249±0.20	30.007±0.00
21000Hz	Pass	11.956±0.11	11.81	11.81	11.81	31.249±0.20	30.007±0.00
48120Hz	Pass	11.956±0.11	11.03	10.80	10.80	31.249±0.20	30.007±0.00

04 - General Use PPA - PPA Equipment

Released under the Official Information Act 1982



Summary

Mod	FD (2015-2016)	DPF FD (2015-2016)
EDUCATION	-	-
DP500, 0000, No.1, J19	9.20	22.56
DP500, 0000, No.2, J19	9.44	22.70
DP500, 0000, No.3, J19	9.77	22.88
DP500, 0000, No.4, J19	9.23	22.74
DP500, 0000, No.5, J19	9.60	22.57
DP500, 0000, No.6, J19	9.58	22.40
AGRICULTURE	-	-
DP500, 0000, No.1, J19	9.17	22.80
DP500, 0000, No.2, J19	9.05	22.80
DP500, 0000, No.3, J19	9.77	22.73
DP500, 0000, No.4, J19	9.05	22.51
DP500, 0000, No.5, J19	9.17	22.73
DP500, 0000, No.6, J19	9.39	22.77

DP500, 0000, No.1, J19

Released under the Official Information Act 1982



Result

Block	Result	DC (dB)	Part 1 (dBm/Hz)	Part 2 (dBm/Hz)	PD (dBm)	CSP PD (dBm)	ERP PD Limit (dBm)
OPTICAL RANGE, N411, J11							
800MHz	Pass	-11.00	-111	-113	-8.03	-22.90	-21.00
810MHz	Pass	-11.00	-111	-113	-8.04	-22.71	-21.00
840MHz	Pass	-11.00	-110	-111	-8.71	-22.88	-21.00
850MHz	Pass	-11.00	-110	-111	-8.01	-22.90	-21.00
870MHz	Pass	-11.00	-110	-111	-7.71	-22.88	-21.00
880MHz	Pass	-11.00	-110	-111	-8.71	-22.71	-21.00
OPTICAL RANGE, N411, J11							
890MHz	Pass	-11.00	-111	-110	-8.71	-22.14	-21.00
910MHz	Pass	-11.00	-110	-111	-8.00	-22.71	-21.00
940MHz	Pass	-11.00	-110	-111	-8.98	-25.49	-21.00
945MHz	Pass	-11.00	-110	-110	-8.41	-22.21	-21.00
950MHz	Pass	-11.00	-110	-111	-8.71	-22.71	-21.00
955MHz Bluetooth & ISM 4.2/2.4GHz	Pass	-11.00	-110	-110	-8.28	-22.79	-21.00

DC - Decibel value (dB) relative to 1mW
 Part 1 - Decibel value (dBm/Hz) relative to 100Hz bandwidth
 Part 2 - Decibel value (dBm/Hz) relative to 1000Hz bandwidth
 PD - Decibel value (dBm) relative to 1000Hz bandwidth
 CSP PD - Decibel value (dBm) relative to 1000Hz bandwidth
 ERP PD Limit - Decibel value (dBm) relative to 1000Hz bandwidth

Released under the Official Information Act 1982

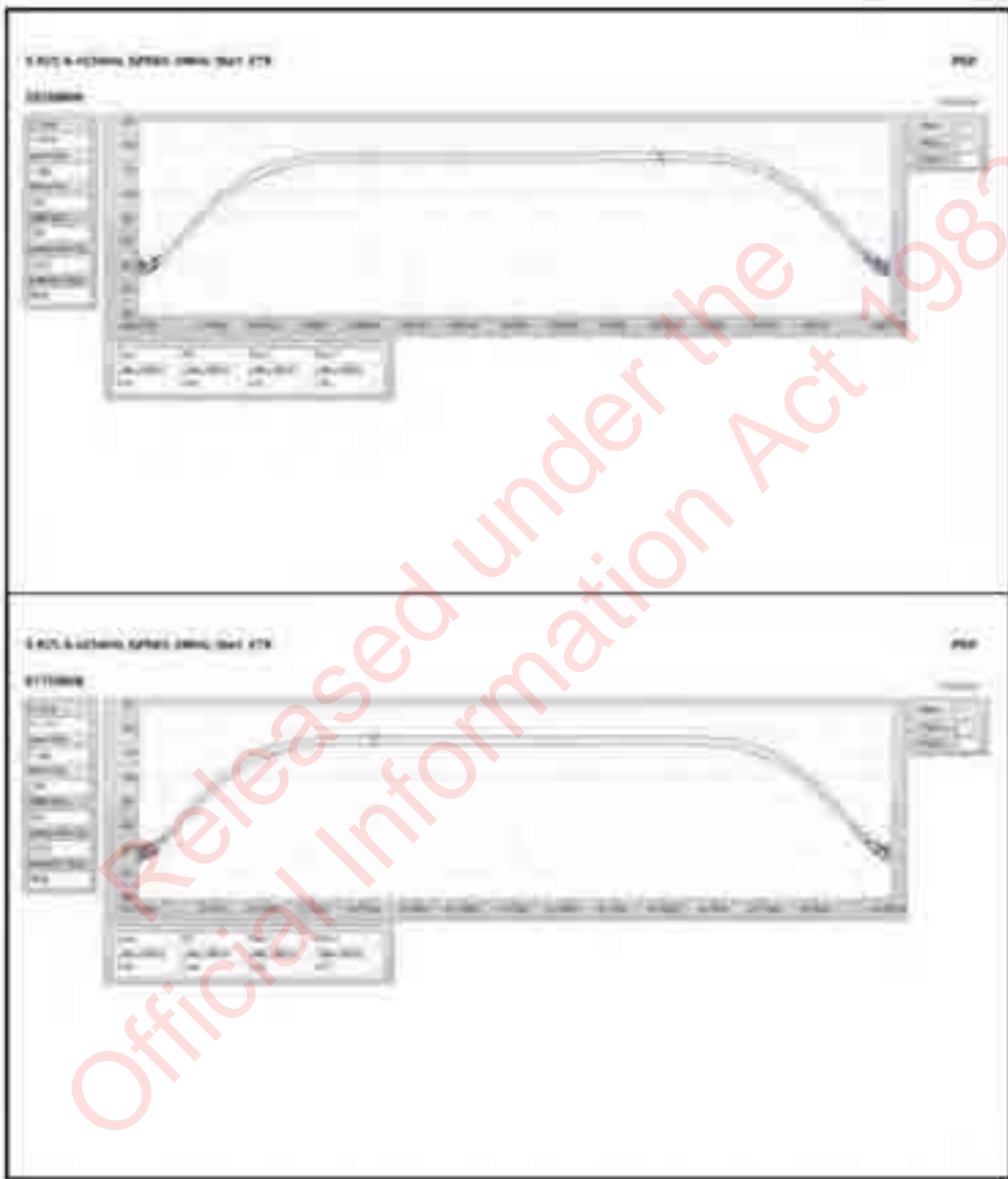

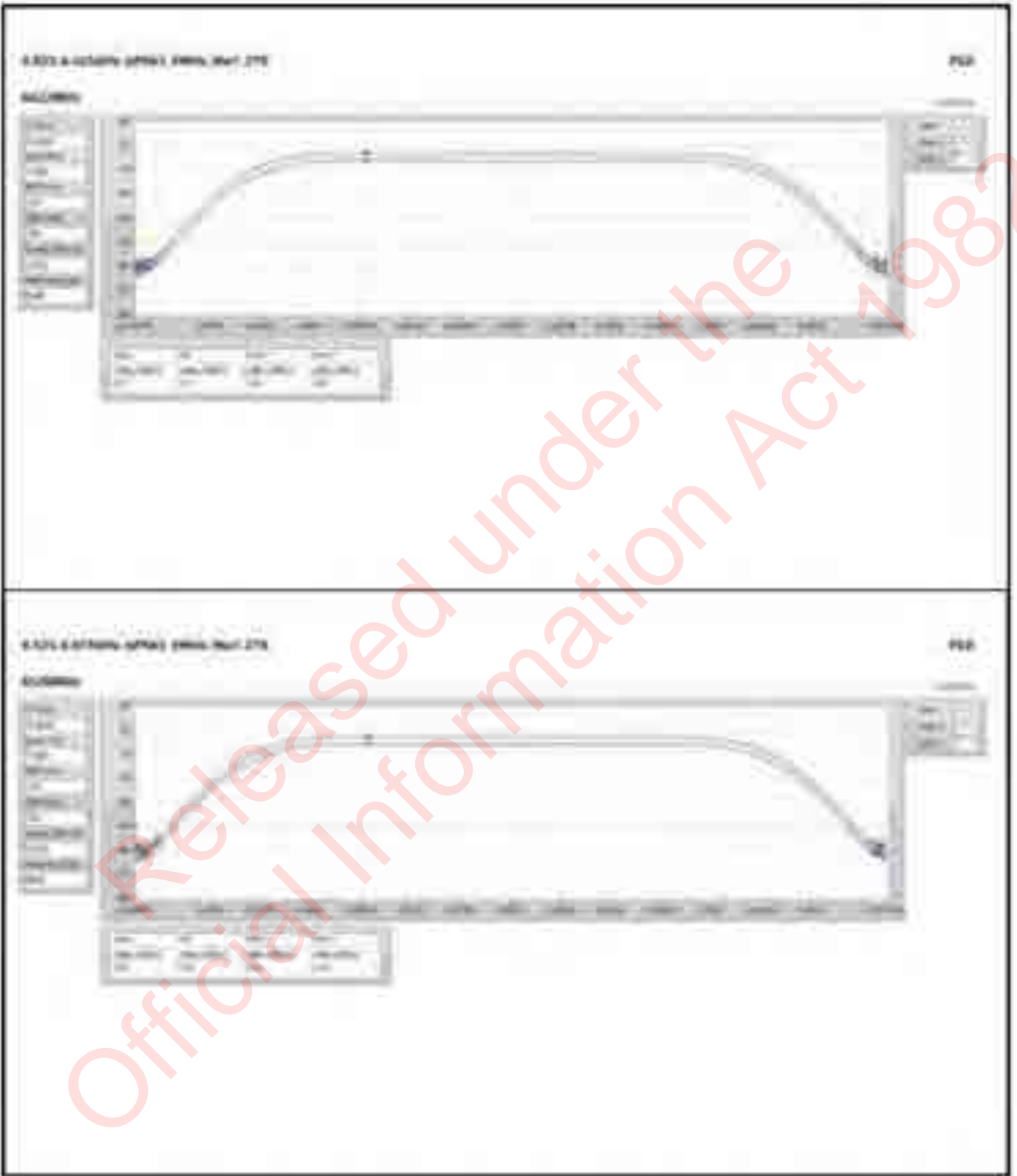

Released under the Official Information Act 1982

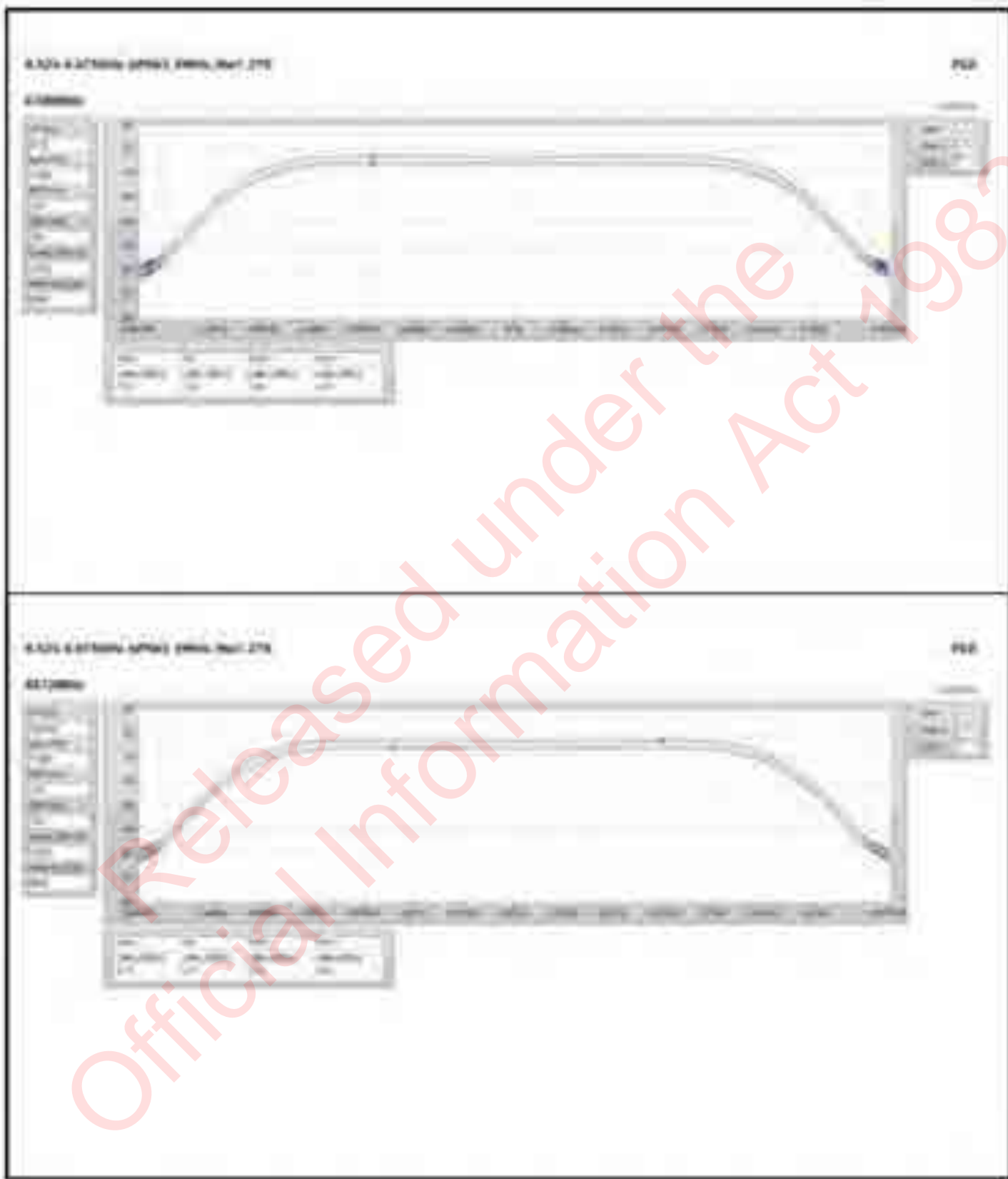

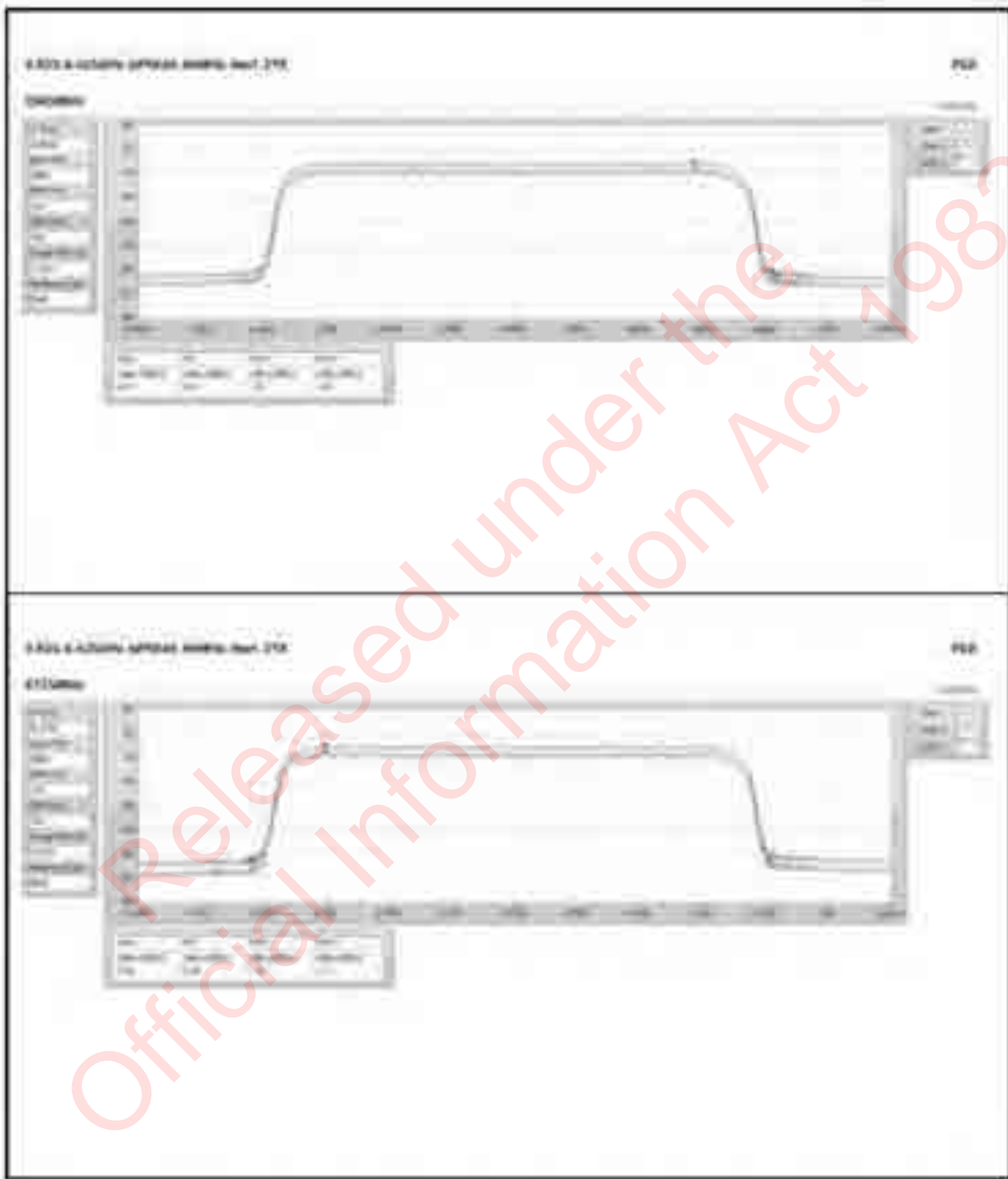



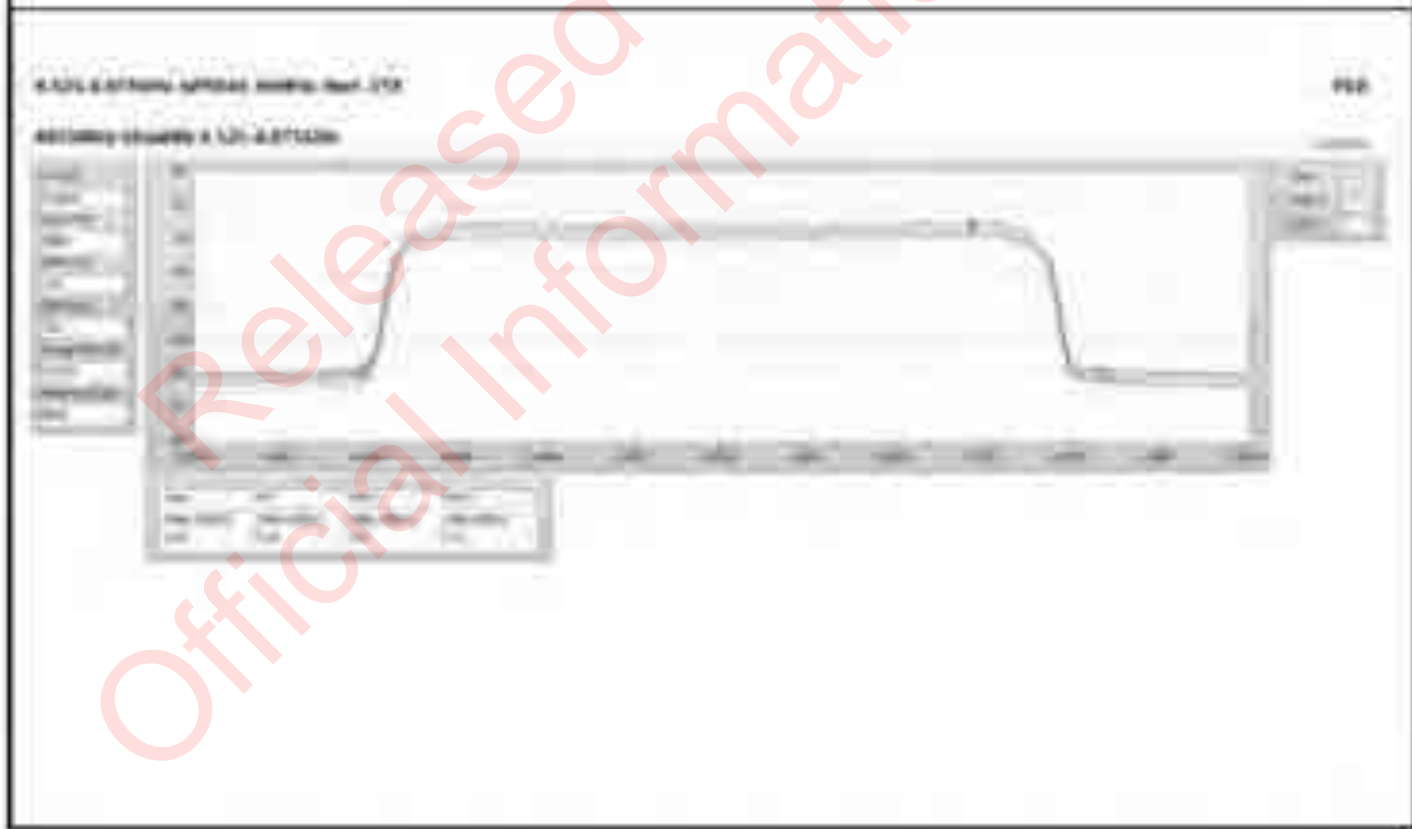
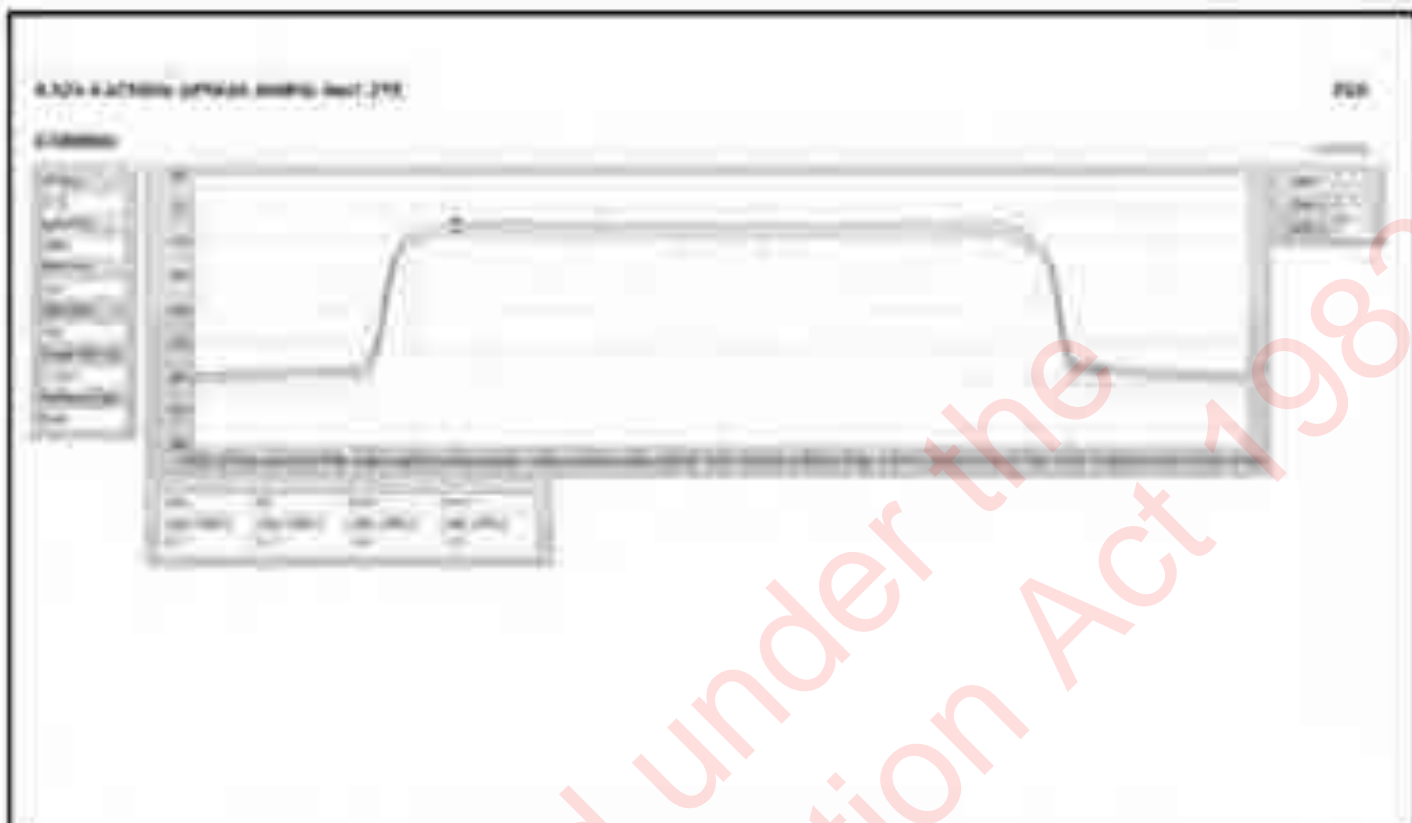



Summary

Mode	Result	Type	Freq (Hz)	Level (dBµV/m)	Limit (dBµV/m)	Margin (dB)	Condition
Mode 1	Pass	PK	896.21M	-42.50	-48.00	+5.50	FullScale

Released under the
Official Information Act 1982



Released under the Official Information Act 1982



Table 2

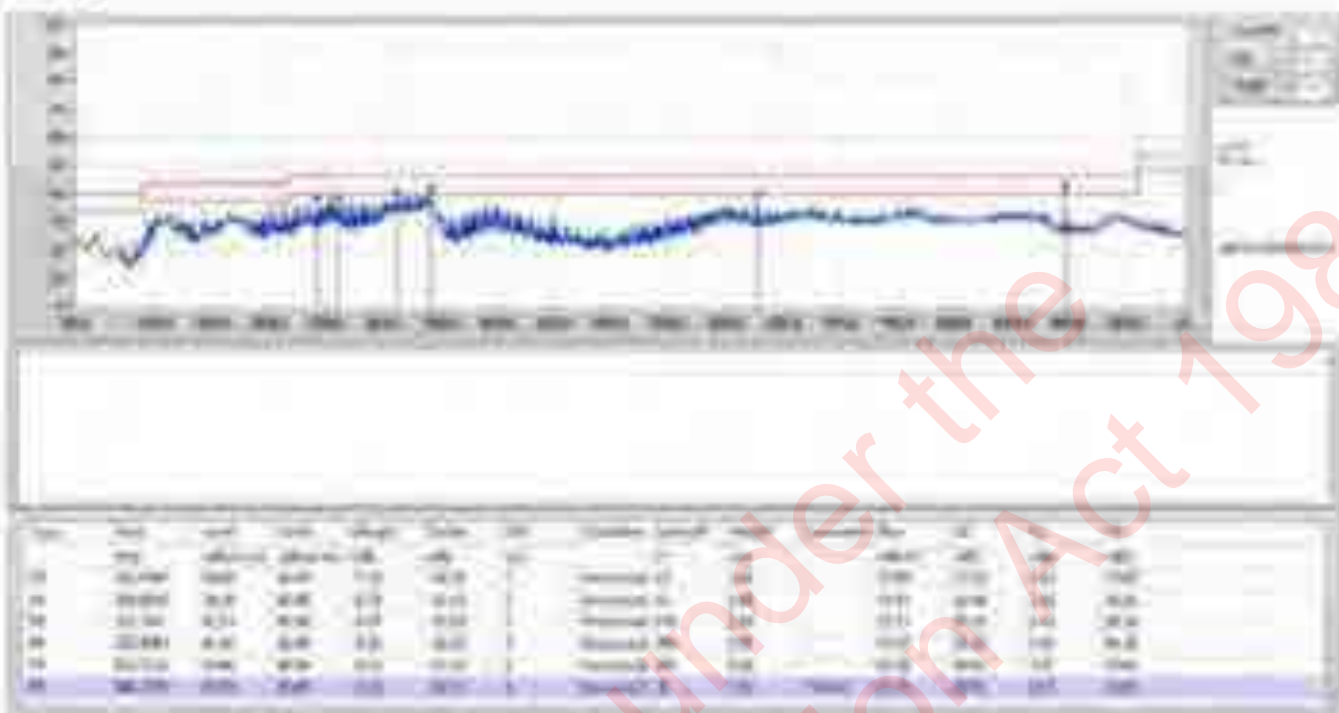

Released under the Official Information Act 1982



Summary

Model	Model	Type	Frequency (MHz)	Power (dBm)	Power (dBm)	Weight (kg)	Site ID	Location	Altitude (m)	Height (m)	Comments
EPA Station											
SPRINT 9000 Rev. 270	Power	ISM	5.5/5.8	18.74	18.72	0.05	1	Atlanta	0	100	18.74

Released under the
Official Information Act 1982



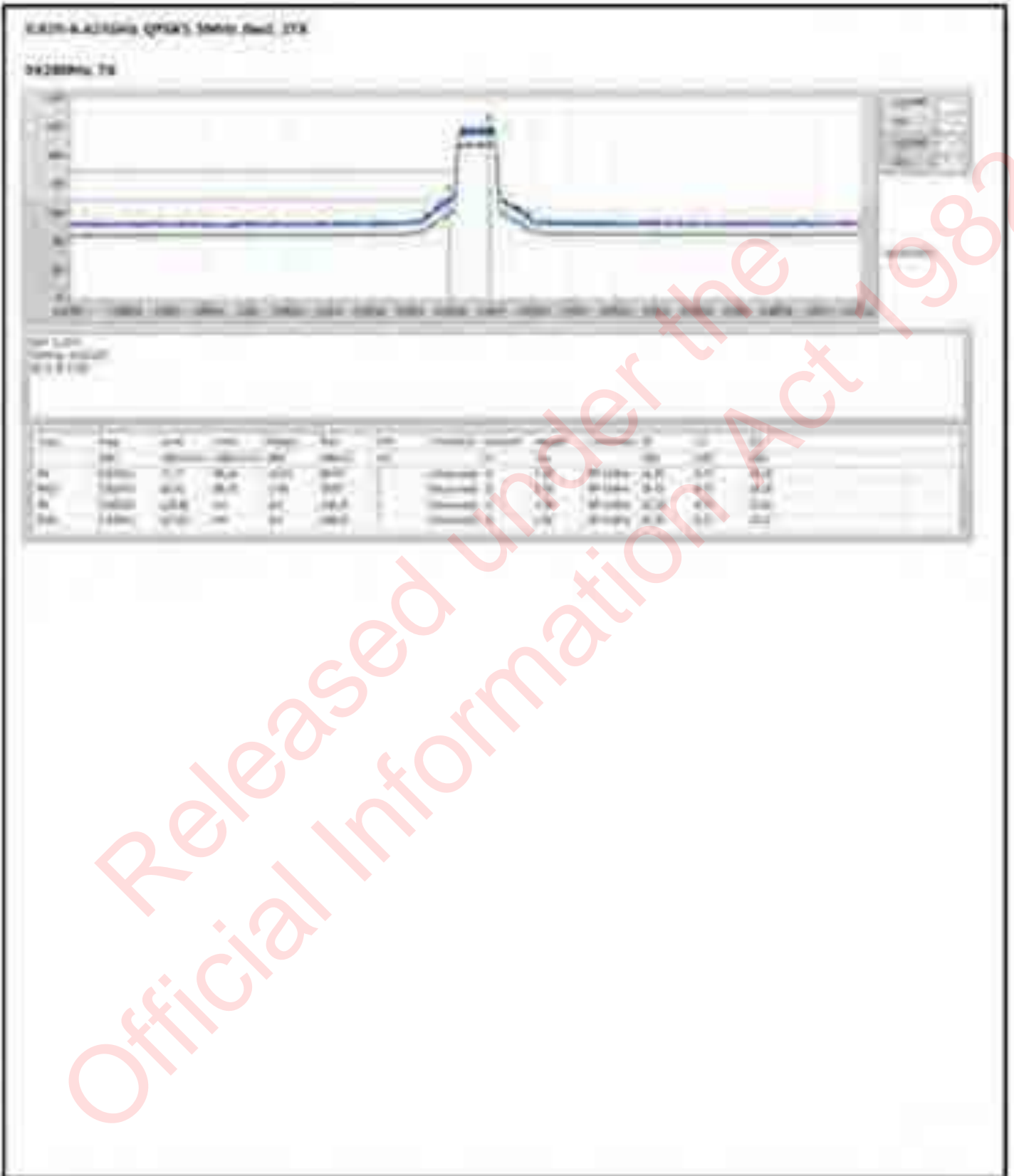











Released under the
Official Information Act 1982



Released under the Official Information Act 1982



Released under the
Official Information Act 1982





Released under the Official Information Act 1982



Released under the Official Information Act 1982



Released under the
Official Information Act 1982





Released under the
Official Information Act 1982





Released under the
Official Information Act 1982



Released under the Official Information Act 1982



Released under the
Official Information Act 1982



Released under the
Official Information Act 1982



Released under the
Official Information Act 1982







Released under the Official Information Act 1982



Released under the Official Information Act 1982

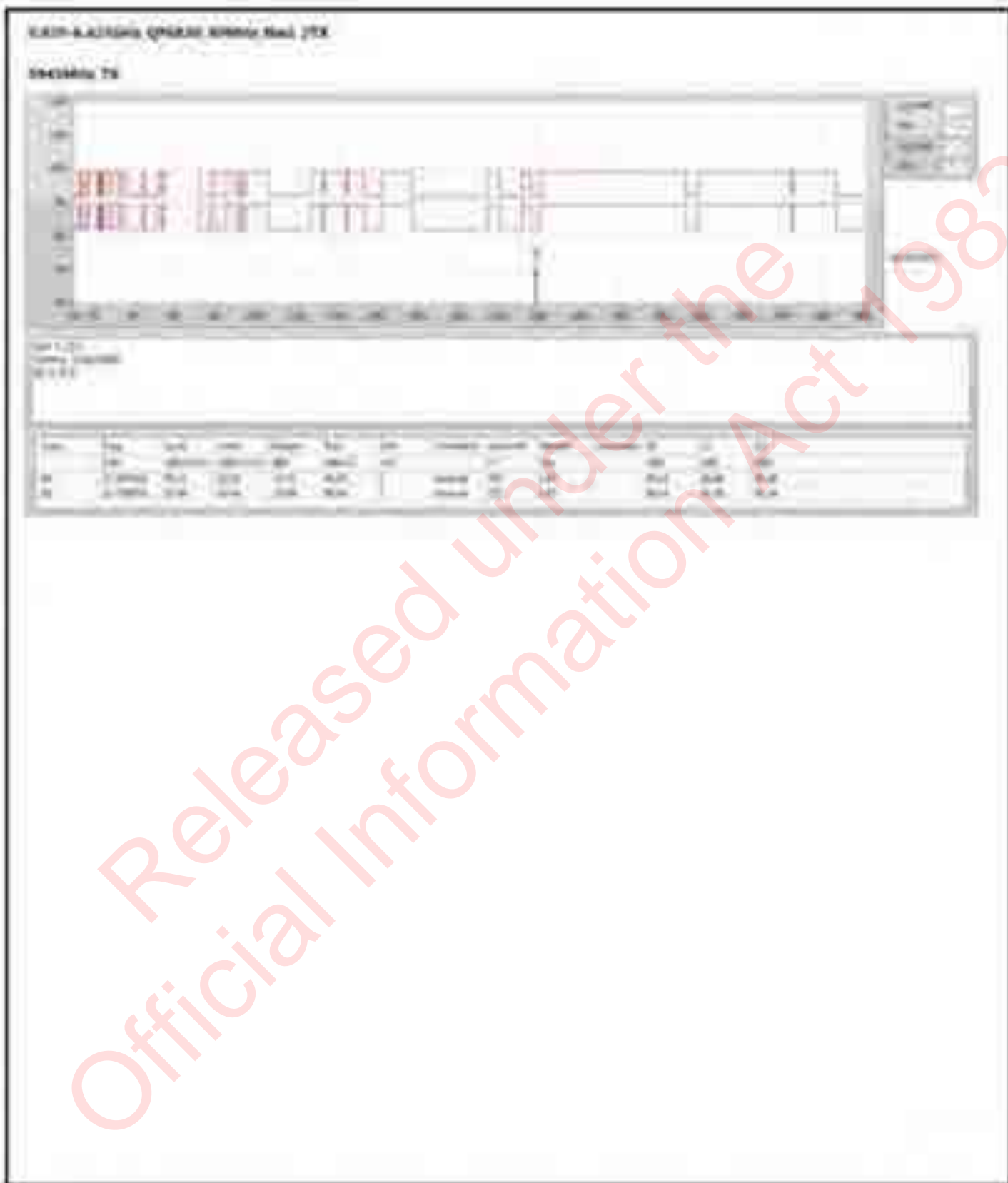

Released under the Official Information Act 1982

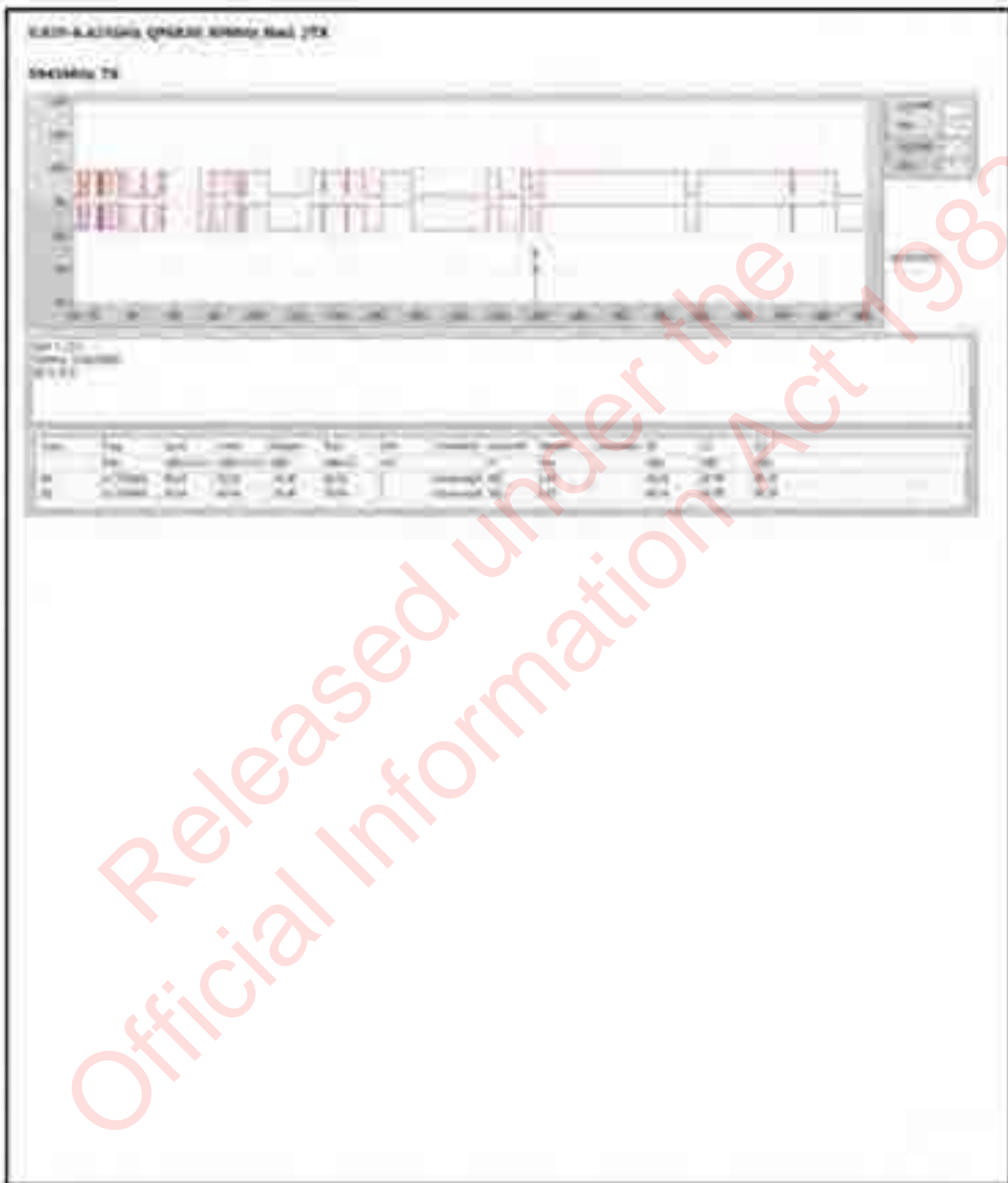

Released under the
Official Information Act 1982



Released under the Official Information Act 1982



Released under the Official Information Act 1982



Released under the
Official Information Act 1982



Released under the Official Information Act 1982



Released under the Official Information Act 1982



Released under the Official Information Act 1982



Released under the Official Information Act 1982











Released under the Official Information Act 1982



Released under the
Official Information Act 1982



Released under the Official Information Act 1982



Released under the Official Information Act 1982



Released under the
Official Information Act 1982



Released under the Official Information Act 1982

