

















- Legend:**
-  Existing kerb and channel
 -  AC footpath reconstruction:
-Remove existing A/C footpath surfacing and
restate as per detail drawing 710613-SD-03
-AP40 basecourse to be used as required to suit
levels (Typical thickness 100mm)
 -  Bus stop & Road reconstruction
-Reconstruct road as per detail drawing
710613-SD-03
-70mm asphaltic concrete, polymer modified
AC14
-300mm 3% cement stabilised M/4 AP40
compacted in two layers
-200mm AP65 sub-base
-Assumed CBR of 7%. Contractor to confirm
CBR
 -  Concrete Apron Strip
-150mm wide, 150mm deep
-20MPa Concrete
-Exposed aggregate finish
-Saw cuts at 4m intervals, positioning to be
agreed with the Engineer on site
 -  WCC standard Kerb and Channel
-Install as per detail drawing 710613-SD-02
 -  Kassel Kerb
-Install as per detail drawing 710613-SD-02
 -  Transition Kerb between Kerb and
Channel and Kassel Kerb
-Install as per detail drawing 710613-SD-02
 -  Building roofline
 -  Sump
 -  Pedestrian Ramp
-Install as per detail drawing 710613-SD-02
 -  Proposed bench
 -  Services Pit

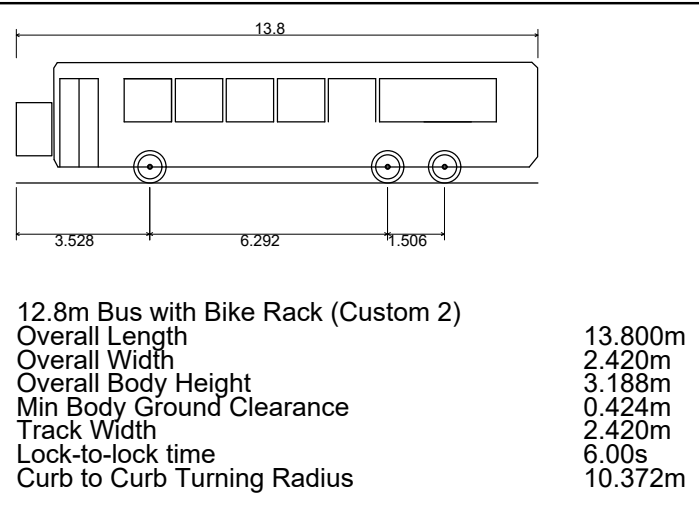
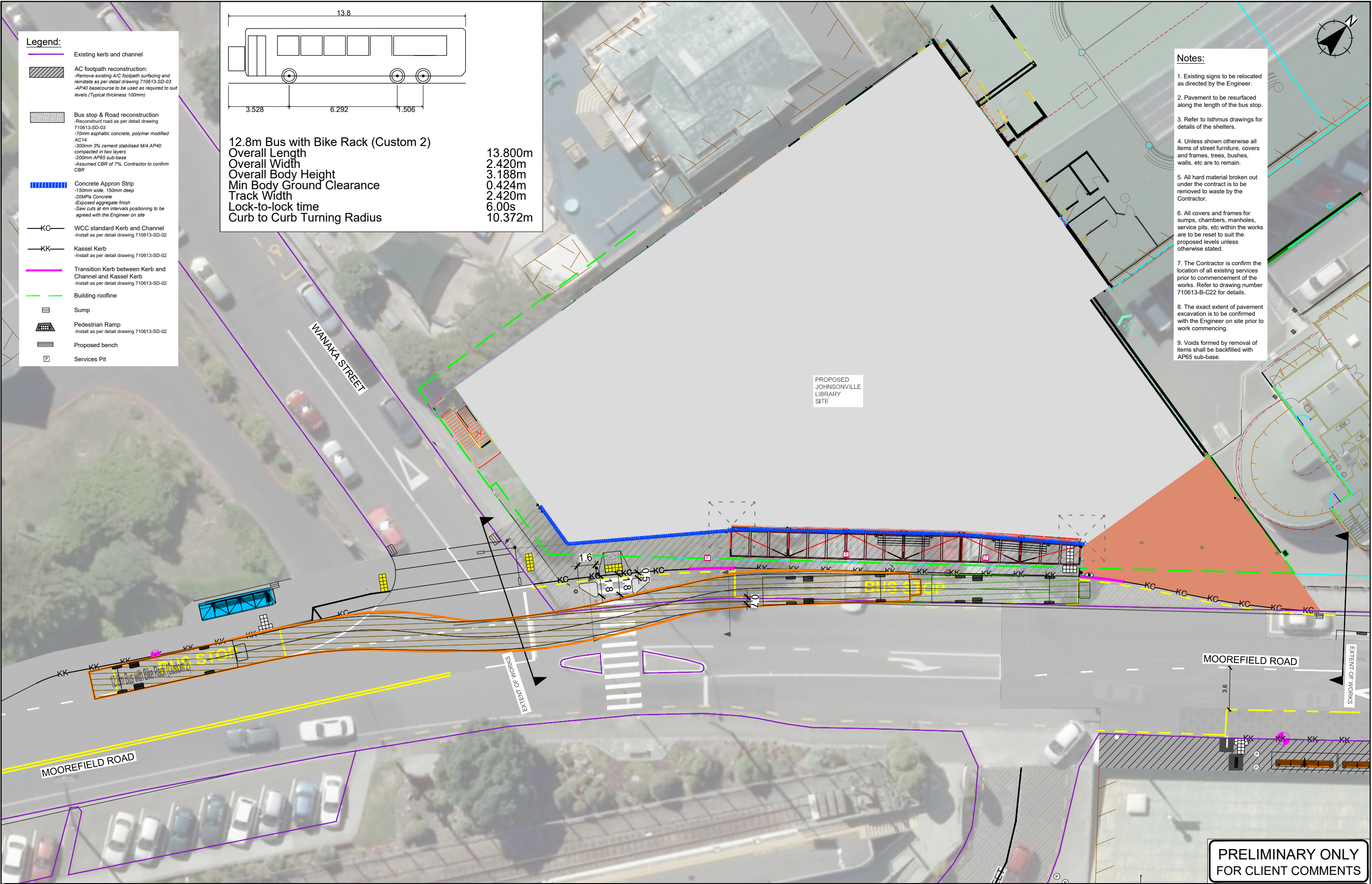

- Notes:**
1. Existing signs to be relocated as directed by the Engineer.
 2. Pavement to be resurfaced along the length of the bus stop.
 3. Refer to Isthmus drawings for details of the shelters.
 4. Unless shown otherwise all items of street furniture, covers and frames, trees, bushes, walls, etc are to remain.
 5. All hard material broken out under the contract is to be removed to waste by the Contractor.
 6. All covers and frames for sumps, chambers, manholes, service pits, etc within the works are to be reset to suit the proposed levels unless otherwise stated.
 7. The Contractor is confirm the location of all existing services prior to commencement of the works. Refer to drawing number 710613-B-C22 for details.
 8. The exact extent of pavement excavation is to be confirmed with the Engineer on site prior to work commencing.
 9. Voids formed by removal of items shall be backfilled with AP65 sub-base.



**PRELIMINARY ONLY
FOR CLIENT COMMENTS**

	A Issued for Client Comments																										
	Revision	App	Date	Approved	Client	Project Title	Sheet Title	Scale (A1 Original) 1:150 (A3) 1:300																			
<table border="1" style="width: 100%; border-collapse: collapse;"> <tr><td>Surveyed</td><td>BECA</td><td>10/15</td></tr> <tr><td>Designed</td><td>HC</td><td>04/19</td></tr> <tr><td>Drawn</td><td>HC</td><td>04/19</td></tr> <tr><td>Reviewed</td><td></td><td></td></tr> </table>				Surveyed	BECA	10/15	Designed	HC	04/19	Drawn	HC	04/19	Reviewed				GWRC - Bus Hubs	Site B - Johnsonville Stop A General Arrangement & Site Clearance	Level 13 Kordia House 109-125 Willis Street Wellington 6011 +64 4 384 2029 calibregroup.com		<table border="1" style="width: 100%; border-collapse: collapse;"> <tr><td>Project No</td><td>710613</td></tr> <tr><td>Sheet</td><td>SK46</td></tr> <tr><td>Revision</td><td>A</td></tr> </table>	Project No	710613	Sheet	SK46	Revision	A
Surveyed	BECA	10/15																									
Designed	HC	04/19																									
Drawn	HC	04/19																									
Reviewed																											
Project No	710613																										
Sheet	SK46																										
Revision	A																										